

Precaution for Insulation Displacement Process

The following instructions describe the procedure to be adopted when terminating Insulation Displacement connectors. Please read the relevant I.D.Connector and application tooling “Handling Manuals” prior to terminating the connector. If you need any further information, please contact JST.

1. Insulation Displacement tools

When JST insulation displacement connector (ID connector) are terminated with wires, always use application tooling specified by JST. If this process is conducted using application tooling other than that specified, product defect and failure may occur. JST cannot accept any liability for failures due to the use of incorrect tooling.

2. Applicable wires

Wire to be used for ID connector, please use the wire that is specified by JST

As applicable wire for ID connector differs in the characteristics of wire insulation by the manufactures, wire evaluation test shall be carried out by JST, and propriety of wire applicability shall be determined. Please contact JST about suitability of the wire to be used.

3. Composition and Parts Identification of IDC

Composition and parts identification of ID connector are shown in the below figure.

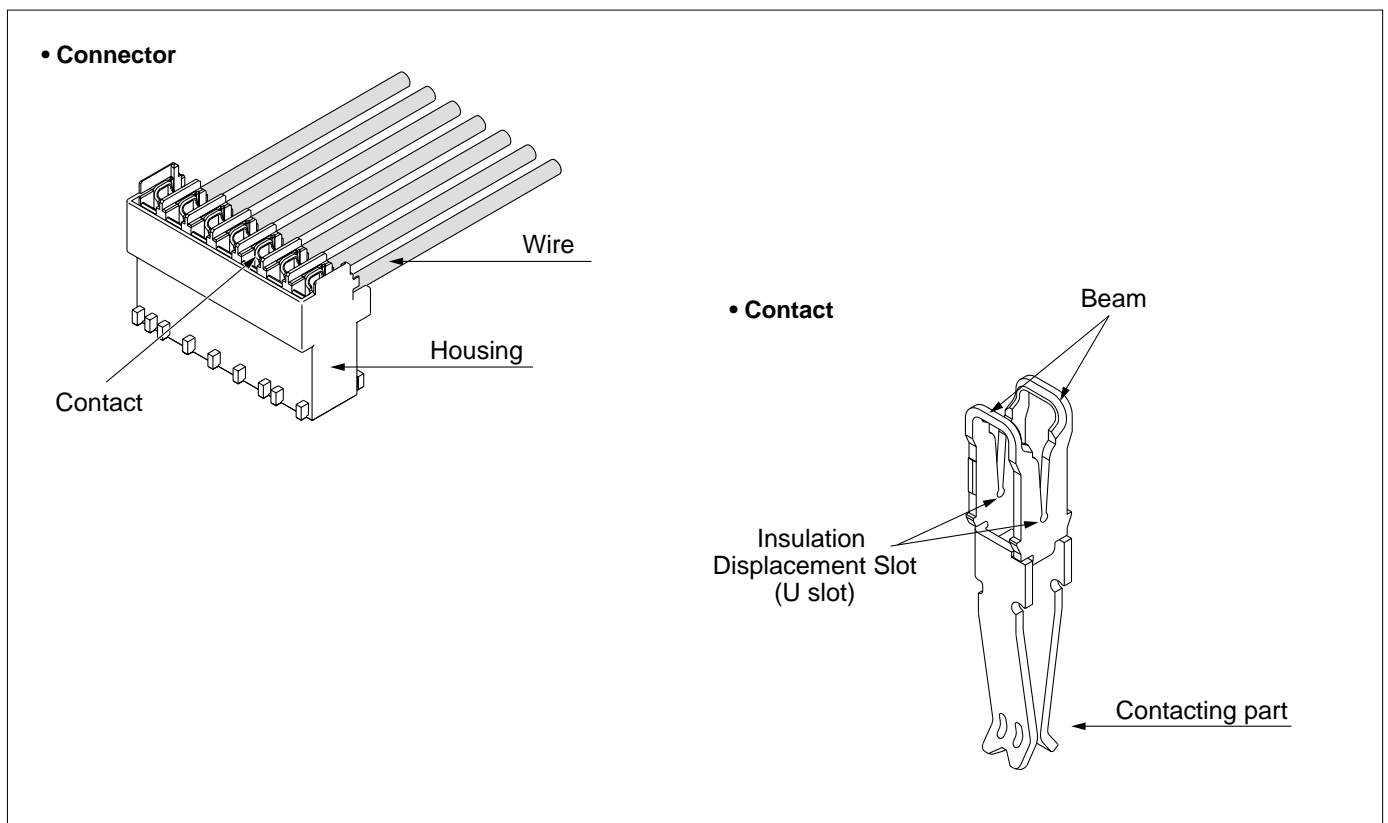

Precaution for Insulation Displacement Process

4. Control Points for Insulation Displacement Operation

In order to perform a good insulation displacement connection, please study the following points.

4.1 Insulation Displacement Machine

Handling Manuals are available for each type of JST application tool. Please study the Handling Manual prior to using the tooling.

<Main Check Points>

① Hand Press

- Correct shut-height
- Set connector at the correct position
- No particles of wire insulation on the termination punch

② Pneumatic Press

- Air pressure should be within specified range.
- Set connector at the correct position
- No particles of wire insulation on the termination punch

③ Automatic ID Machine

- Each part should move freely.
- Connector should be correctly fed at bowl-feeder and straight chute
- Adequate tension should be applied to wire
- Measuring wire length should be correctly set up to specified wire length
- Connector should be set at the correct position
- If a connector with a different number of circuits is to be used, check that any previously used connectors are removed from track and bowl-feeders.
- No particles of wire insulation on the termination punch or wire guide.

4.2 Connector & Wire Size

Each ID connector has been designed for specified the wire size, please ensure that the correct connector is selected for use with the applicable wire conductor size from Handling Manual etc.

4.3 Termination Depth

A specific termination depth has been developed for each particular wire and connector combination. Please ensure that the applicable Handling Manual is checked for the particular wire size that is chosen to be used.

4.3.1 What is Termination Depth

The termination depth is used as a running check during production of the ID harness. This disposes of the requirement to check the termination depth using destructive methods. Each connector has a u-slot designed for a specific conductor wire size, therefore providing the wire used is within specification of the connector, it is only necessary to manage the depth of the wire in the u-slot during production. The true termination depth is “d” in the figure of next page, i.e. check the position of center of wire conductor from bottom of U slot. However, as the result of checking the condition of the insulation displacement at U-slot and measuring wire retention force, we specify termination depth “D” as the checking point during production.

Precaution for Insulation Displacement Process

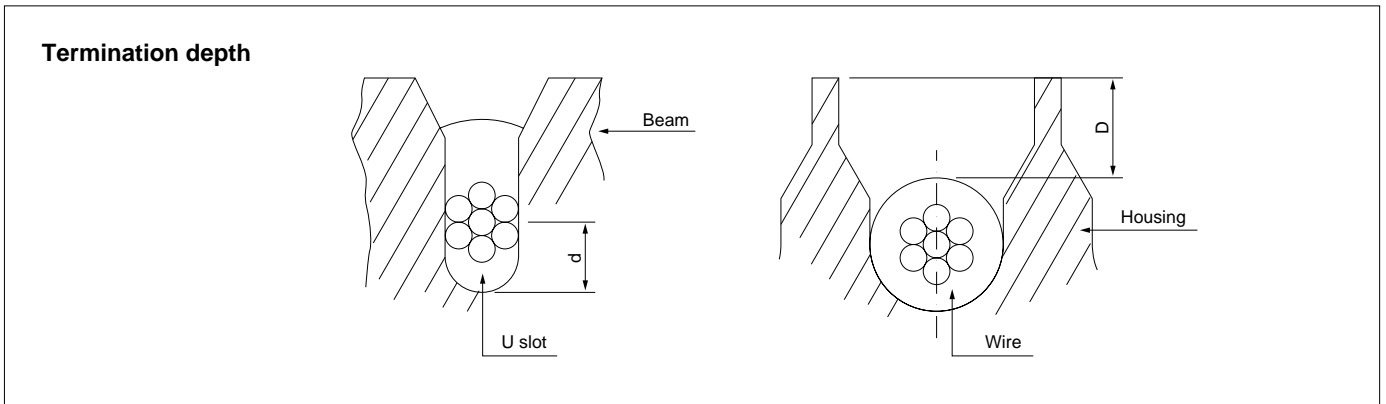

4.3.2 How to Measure Termination Depth

The termination depth shall be measured in the figure below at X-X' part, where is in the middle part of two U slots and a flattened part pressed by termination punch, immediately after termination operation. If the termination depth is not measured immediately after the termination operation, the insulation will try and revert to its original shape and correct termination depth can not be measured.

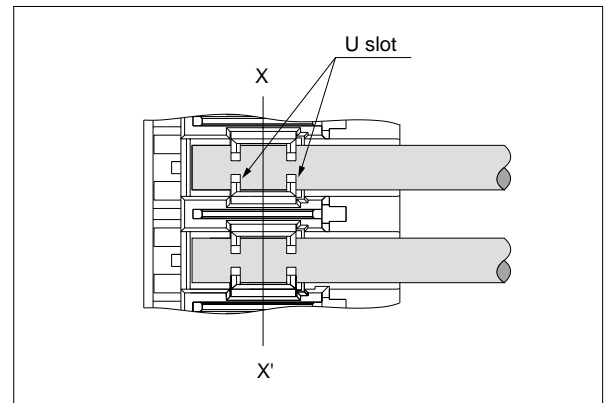

4.4 Wire Retention Force

Wire retention force is specified for each combination between ID connector and wire.

The wire retention force is specified in the applicable connector Handling Manual.

The terminated wire shall be pulled one by one in the direction of arrow in the figure below, and wire retention force shall be measured by a push-pull gauge etc. When the wire pulls out of the contact, it should be checked that wire retention force is in compliance with the requirement for each ID connector.

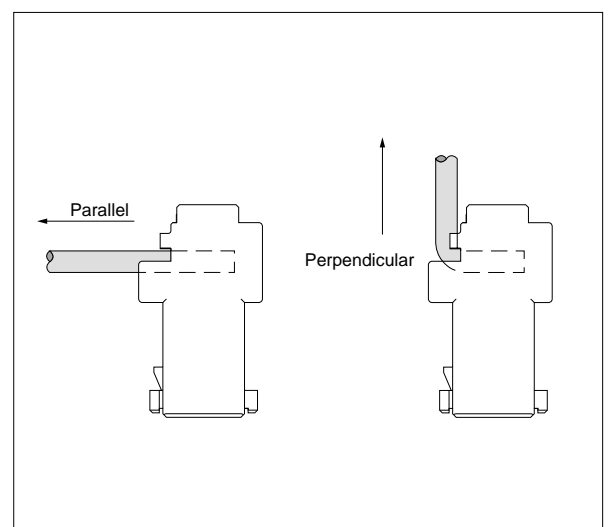

Precaution for Insulation Displacement Process

4.5 Termination Appearance

Check termination appearance visually (using loupe etc.) in order to confirm correct termination.

As the inspection items change with each ID connector, an example is shown below.

Check the Handling Manual for each ID connector about the specific details to be checked.

Defects or deformation on housing

Check for defects or deformation on housing

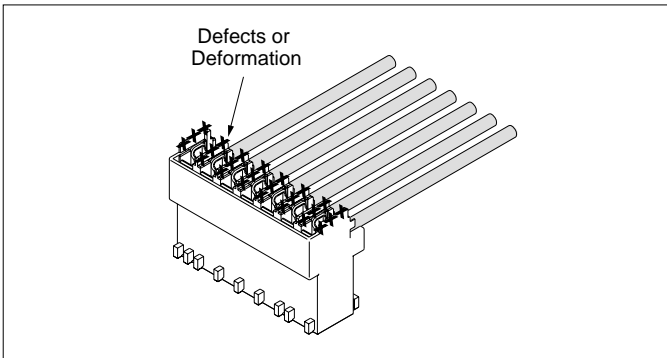

Defects or deformation on Contact

Check for defects or deformation on contact

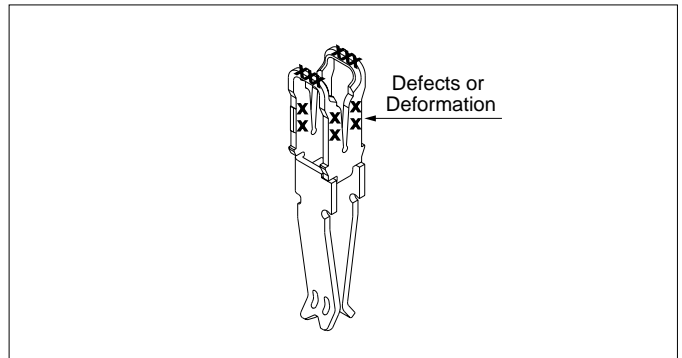

Exposure of wire conductors around beam of contact

Check that the wire conductors are not exposed around the beam of contact.

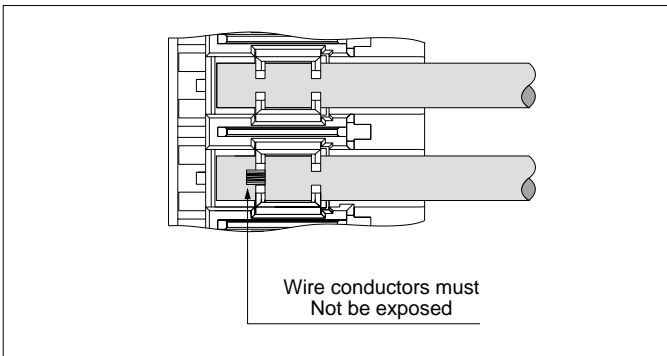

Gap between housing wall and wire tip (Wire protruding length)

Check gap "G" between housing wall and wire tip

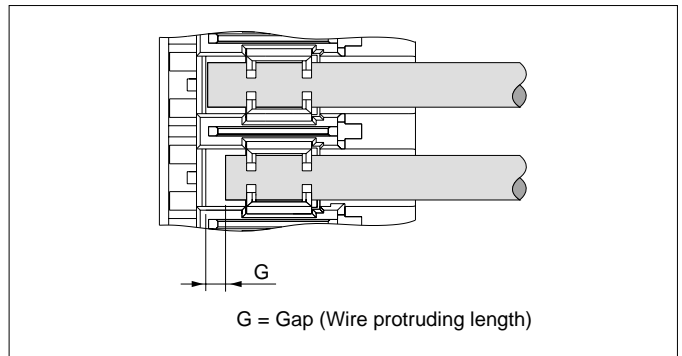

Overrun of wire

Check for overrun of wire

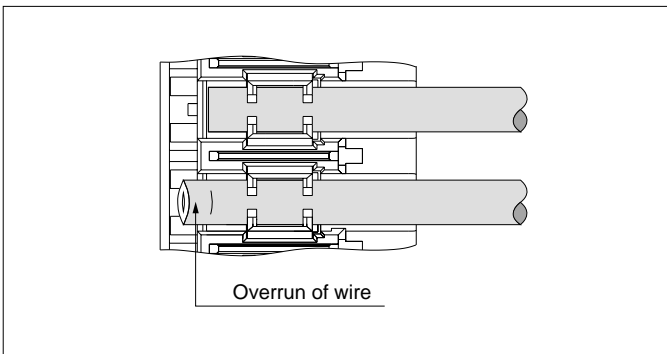

Deviation of ID center

Check for no deviation of insulation displacement center

