

# SWDM: The Lowest Total Cost Solution for 40G/100G in the Enterprise Data Center

By Christian Urricariet

Large- and medium-sized enterprises have been widely deploying 10G Ethernet for several years. Their data center infrastructure has been primarily architected around duplex OM3 and OM4 multimode fiber (MMF), since most of the switch port interfaces are multimode 10GBASE-SR using the SFP+ transceiver form factor. Consequently, IT staff (both in-house and outsourced) responsible for the installation and operation of data centers are very familiar and comfortable with using duplex patch cords with its associated LC connector in the rack. The LC connector is the most successful optical connector in the market so far, with its characteristic “clicking” sound to confirm proper latching, as well as its simple termination and cleaning.

As these data centers begin their transition to 40G and 100G Ethernet, enterprise IT architects had a choice to make until now:

1. They could use 40GBASE-SR4 and 100GBASE-SR4 optical transceivers, which have become very cost-effective but which require the use of parallel optics infrastructure. This means having to replace their duplex LC patch cords with parallel MPO patch cords, as well as installing additional trunks/structured cabling (since each full-duplex link now would require eight fibers instead of only two). This approach is not only CapEx-intensive, but also may increase OpEx substantially given the unfamiliarity of the IT networking personnel with the handling/cleaning of

the MPO connector. Depending on the data center size, an additional disadvantage is that these IEEE interfaces support a shorter reach (100/150m for 40G, and 70/100m for 100G on OM3/OM4 MMF) than the currently deployed 10GBASE-SR (300/400m on OM3/OM4 MMF).

2. The other option was to install single mode fiber to continue to use the familiar duplex fiber/LC-connector paradigm. This means using 40GBASE-LR4 and 100GBASE-LR4 (or CWDM4) optical transceivers, which have a significantly higher cost than multimode SR4 transceivers. This is a very CapEx- and OpEx-intensive approach, with the advantages of eliminating cost in IT personnel re-training to use the MPO connector, as well as substantially increasing the link distance (if that were a requirement). It could be argued that a potential additional advantage of this single mode option is the future-proofing of the infrastructure for deployments beyond 100G Ethernet. However, the IEEE is already standardizing multimode 400G interfaces suitable for the enterprise data center environment, which are expected to be available by the time most of that market segment is ready for the transition.

## Leveraging Existing Fiber Infrastructure for Data Center Upgrades

Neither of the options above is particularly attractive. Ideally, enterprises would like to upgrade their data centers to 40G/100G Ethernet **without changing their existing duplex multimode fiber infrastructure being used for 10G Ethernet.**

# SWDM: The Lowest Total Cost Solution for 40G/100G in the Enterprise Data Center

Also, many would like to maintain the same supported link distances as 10G Ethernet.

Pluggable optical transceivers with **Shortwave Wavelength Division Multiplexing** ("SWDM") technology address this market need. The approach consists of multiple VCSELs operating at different wavelengths in the 850nm window (where multimode fiber is optimized). The four-wavelength implementation of SWDM is called SWDM4, and these four wavelengths are multiplexed/demultiplexed inside the QSFP transceiver into a pair of

multimode fibers (one fiber in each direction, i.e., a standard duplex interface). Each of the four wavelengths operates at either 10G or 25G, enabling the transmission of 40G (4x10G) or 100G (4x25G) Ethernet over existing duplex multimode fiber, using standard LC connectors. Note that this is a similar approach to what is done in LR4 and CWDM4, but optimized for multimode fiber. The block diagram of a 100G SWDM4 QSFP28 transceiver is shown in Figure 1, and the four SWDM4 wavelengths are shown in Figure 2.

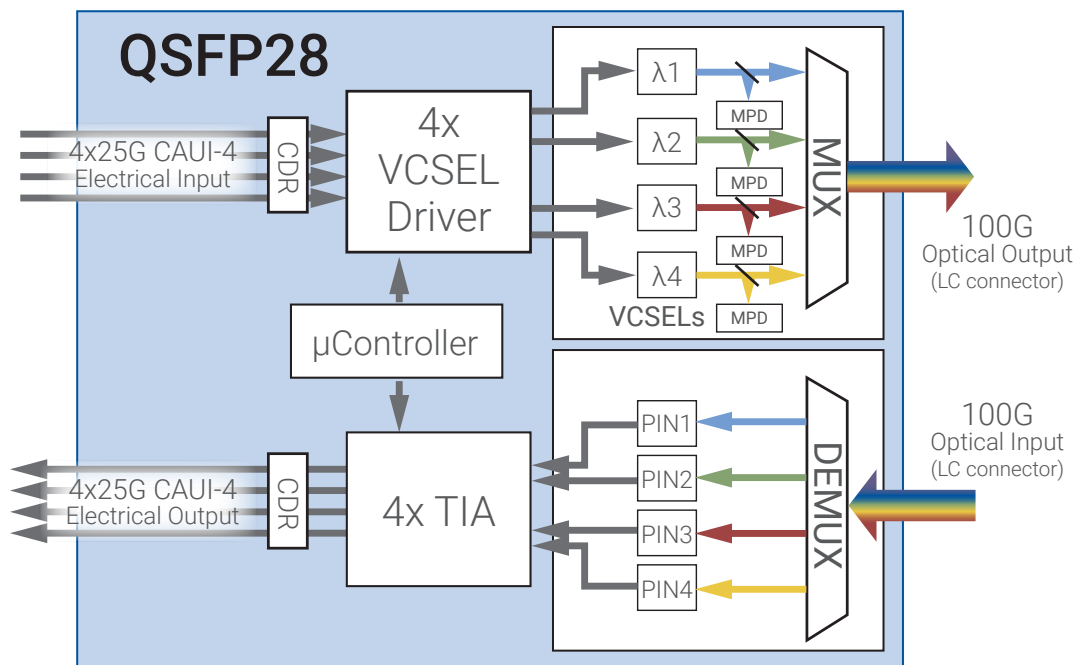

Figure 1: Block Diagram of a 100G SWDM4 QSFP28 Transceiver

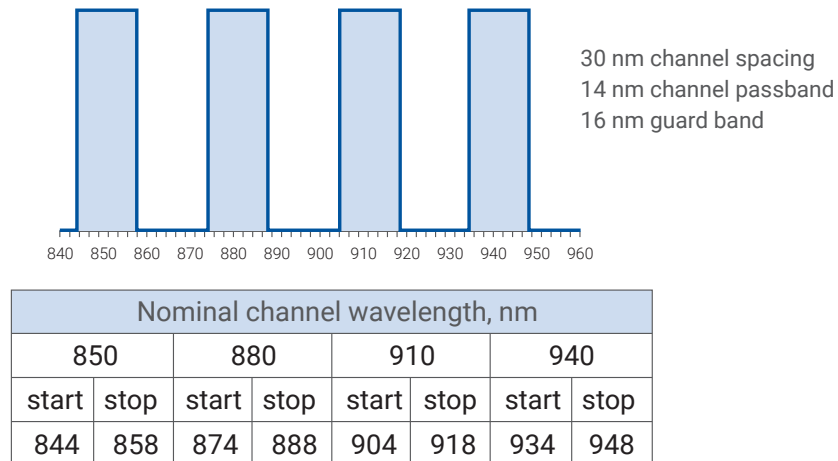

Figure 2: SWDM4 Wavelengths (as defined by the SWDM MSA)

## SWDM: The Lowest Total Cost Solution for 40G/100G in the Enterprise Data Center

The supported reaches for II-VI SWDM4 transceivers are the following:

- 40G SWDM4 QSFP+ transceivers can support up to 300m on OM3 and 400m on OM4 legacy multimode fiber.
- 100G SWDM4 QSFP28 transceivers can support up to 100m on OM3 and 150m on OM4 legacy multimode fiber.

It is important to note that 40G SWDM4 QSFP+ and 100G SWDM4 QSFP28 transceivers meet the same electrical, mechanical and thermal standards as any other QSFP+ and QSFP28, enabling their use in any standard QSFP+ or QSFP28 switch port. Figure 3 shows a 100G SWDM4 QSFP28 transceiver.

### Increasing Bandwidth Density in New Data Center Builds

In addition to the “brownfield” application already described, enterprise users who deploy 40G and 100G SWDM4 interfaces instead of parallel optics in their new data centers will require two fiber strands per full-duplex link instead of eight. This architecture significantly decreases the CapEx required for new trunk/structured cabling infrastructure, while still enabling the use of cost-effective multimode optical transceivers.

### Extending Reach in New Data Center Builds

Some enterprise users who are increasing the size of their new data centers are considering installing single mode fiber cabling and transceivers due to their need to support longer links. This would mean using relatively expensive LR4 or CWDM4 transceivers using duplex fiber with LC connectors to only support a few hundred meters (CWDM4 is optimized for ~2km hyperscale applications), or using a non-mainstream solution like PSM4 which requires the use of a higher fiber count and the relatively unproven single mode MPO connector.

However, a new cost-effective multimode solution to address this requirement has been introduced into the market: By using SWDM4 transceivers with the new OM5 wideband multimode fiber standardized by the TIA TR-42 Subcommittee, the supported 40G and 100G Ethernet distances stated above for OM3/OM4 MMF can be extended. OM5 fiber is particularly well-suited for SWDM since it allows wavelengths up to 953nm to propagate to longer distances. Thus:

- II-VI 40G SWDM4 QSFP+ transceivers can support up to 500m on OM5 multimode fiber.
- II-VI 100G SWDM4 QSFP28 transceivers can support up to 180m on OM5 multimode fiber.

Besides extending the reach, an additional benefit of upgrading to OM5 multimode fiber is future-proofing the fiber infrastructure for future 200G/400G/800G multimode interfaces suitable for the data center which may take advantage of SWDM technology.



Figure 3: 100G SWDM4 QSFP28 Transceiver

# SWDM: The Lowest Total Cost Solution for 40G/100G in the Enterprise Data Center

## Additional Advantages

SWDM technology also provides additional operational advantages with respect to proprietary bidirectional, or “BiDi”, solutions addressing the same market need. The first advantage is supporting longer link lengths. The second is making network monitoring much simpler, since SWDM4 transceivers can be used with standard (not bidirectional) network taps and with standard transceivers on the monitoring equipment, unlike BiDi transceivers.

## Multi-vendor Approach

SWDM technology is not a single-vendor, proprietary solution. A group of companies including optical transceiver suppliers, fiber and cabling vendors as well as system OEMs have formed the SWDM Alliance and the SWDM MSA ([www.swdm.org](http://www.swdm.org)). Their goal is to promote the use of SWDM technology on duplex multimode fiber, as well as to ensure optical interoperability among the different vendors’ SWDM product offerings.

## Conclusions

SWDM is a new multi-vendor technology that promises to provide the lowest total cost solution for enterprise data center upgrades to 40G and 100G Ethernet, by enabling the use of the existing 10G duplex OM3/OM4 multimode fiber infrastructure. It also enables a cost-effective approach to increasing bandwidth density for new data center builds, as well as extending the reach when used with OM5 wideband multimode fiber.

