

<Usage>

(A) Standard Connection

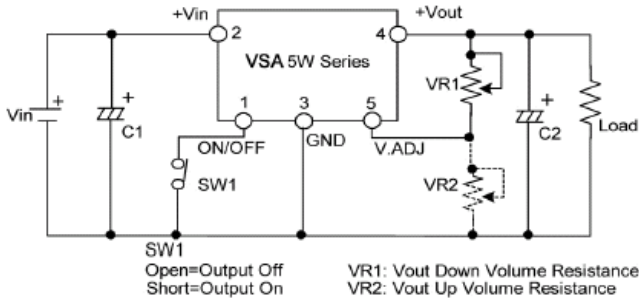

(Figure 4)

(B) ON/OFF Control

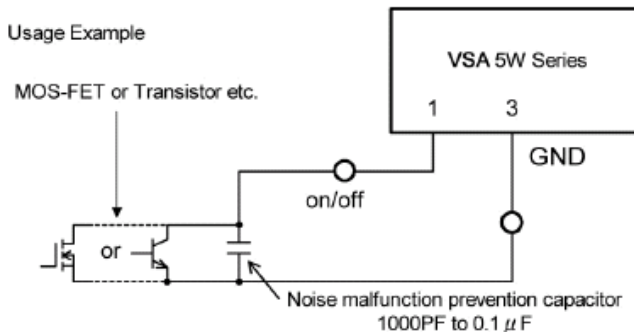

(Figure 5)

Recommended Additional Capacitor

VSA05-2.5S1R2

C1=16ZL330M (Rubycon) or KZE16VB330 (Nippon Chemi-con)

C2=10ZL680M (Rubycon) or KZE16VB680 (Nippon Chemi-con)

VSA24-3.3S1R2

C1=50ZL120M (Rubycon) or KZE50VB120 (Nippon Chemi-con)

C2=10ZL470M (Rubycon) or KZE10VB470 (Nippon Chemi-con)

VSA24-12S0R6

C1=50ZL120M (Rubycon) or KZE50VB120 (Nippon Chemi-con)

C2=16ZL330M (Rubycon) or KZE16VB330 (Nippon Chemi-con)

Note 1: If ON/OFF is not controlled, it should be connected to GND line.

Note 2: When output voltage is rating, please open the terminal V. ADJ (5 pin)

Note 3: I/O capacitor (C1, C2) must be added. Please put I/O capacitor to pin close as much as possible and wire with thick pattern. For C1 & C2, please use low impedance capacitor.

Note 4: For VSA05 model, when the additional capacitor's capacity is large, startup failure may occur. So please use an additional capacitor which capacity is 8,200μF or below.

Input voltage is turned on by using ON/OFF control function, and it is possible for ON/OFF control of output voltage without cutting it. That is the effective function to compose the sequence of Power Supply Systems. Also using this function, you can save the electric power when Power Supply stands by. Please connect the terminal ON/OFF with GND.

Between the terminal ON/OFF (1 Pin) and GND (3 Pin)

VSA05-2.5S1R2

Output voltage OFF mode : OPEN (2V to +Vin)

Output voltage ON mode : SHORT (-0.2 to 0.7V, 10μA)

VSA24-3.3S1R2

Output voltage OFF mode : OPEN (2.5 to 5.3 V)

Output voltage ON mode : SHORT (-0.2 to 0.5 V, 250μA)

VSA24-12S0R6

Output voltage OFF mode : OPEN (2.5 to 5.3 V)

Output voltage ON mode : SHORT (-0.2 to 0.5 V, 250μA)

Note 1: Use an open collector (or drain) switch element for on/ off control.

Note 2: Set the switch element for on/ off control close to the converter, and lessen the noise effect by parallel pattern short loops, or by using shield wires.

To prevent miss operation caused by noise, it is effective to connect a capacitor between the on/ off pin and GND. However, if this capacitor is too large, when impressing the input voltage at off, the charged current may flow and momentarily voltage may occur, so be sure that the max. value is 3300pF.

Note 3: The on/ off pin voltage will be pulled up internally, so it is not necessary to impress voltage externally at off.

(C) Output voltage changeable direction

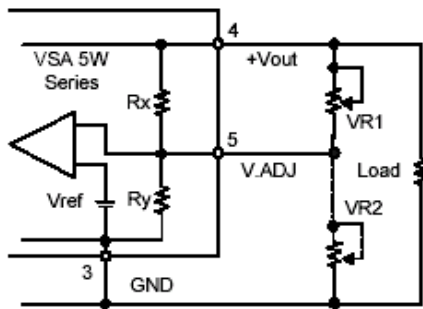

(Figure 6)

Please open the terminal V.ADJ when you use the output voltage with rating, without changing. By connecting resistance between the terminal GND (3 Pin) and V.ADJ (5 Pin), you can change output voltage within the range of voltage in Table 1. Please refer to the undermentioned equation for the calculation of external resistance. Please confirm the output voltage and adjust resistance value after calculating external resistance.

To reduce the output voltage

$$VR1 = \frac{Rx \times Ry \times (Vo - Vref)}{Rx \times Vref - Ry \times (Vo - Vref)}$$

VR2 = OPEN

VO = It is your option.

Model	2.5S	3.3S	12S
Voltage Range	(1.5 to 2.5V)	(3 to 3.3V)	(9 to 12V)
Rx	2.13K ohm	765 ohm	8.6K ohm
Ry	1.0K ohm	2.2K ohm	2.2K ohm
Vref	0.8V	2.45V	2.45V

To add the output voltage (for 2.5V and 3.3V model)

$$VR2 = \frac{Vref \times Rx \times Ry}{Ry \times (Vo - Vref) - Vref \times Rx}$$

VR1 = OPEN

VO = It is your option.

Model	2.5S	3.3S	12S
Voltage Range	(2.5 to 3.3V)	(3.3 to 5V)	N/ A
Rx	2.13K ohm	765 ohm	
Ry	1.0K ohm	2.2K ohm	
Vref	0.8V	2.45V	

Note 1: When using at rating without adjusting the output voltage, keep the V. ADJ pin (5pin) open.

Note 2: V. ADJ pin (5pin) is a high impedance point, so in a bad environment this wiring may pick up noise and cause bad effect. When energizing, avoid switching the output by opening and shortening or switching the adjustable output resistor(R1, R2). And select a R1, R2 that is accurate and has good temperature characteristics, and mount it by soldering without using connectors or sockets when it is pretty close to the converter.



Ultra High Efficiency 82 - 91%
High Efficiency, Small, Low price, Step-Down DC-DC Converter
5 Watt VSA Series

Note: These test data do not represent all products.

<Turn-On transient>

VSA05-2.5S1R2

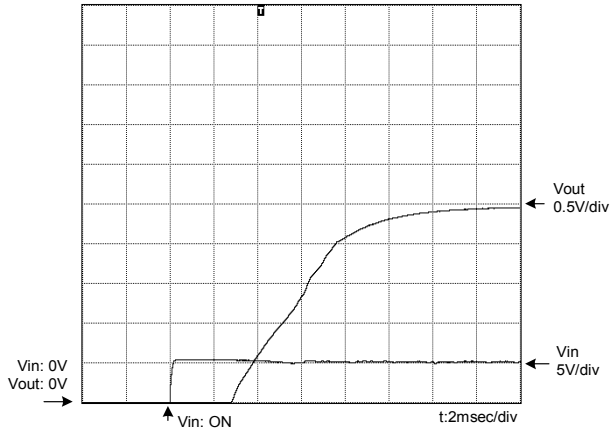

Test conditions: Rating input/Rating load/Room temperature

<Output Ripple & Noise>

VSA05-2.5S1R2

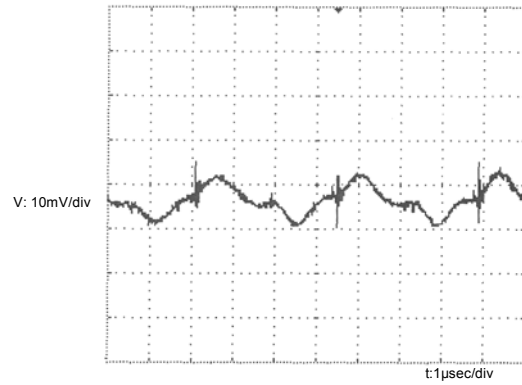

Test conditions: Rating input/Rating load/Room temperature

VSA24-3.3S1R2

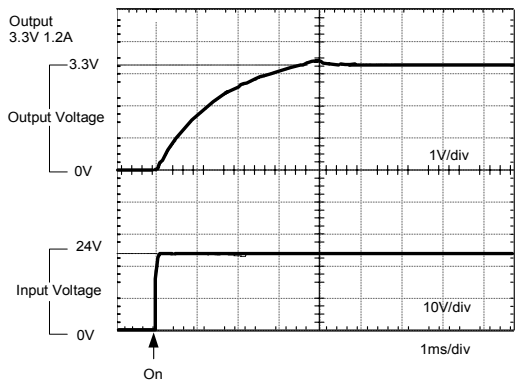

Test conditions: Rating input/Rating load/Room temperature

VSA24-3.3S1R2

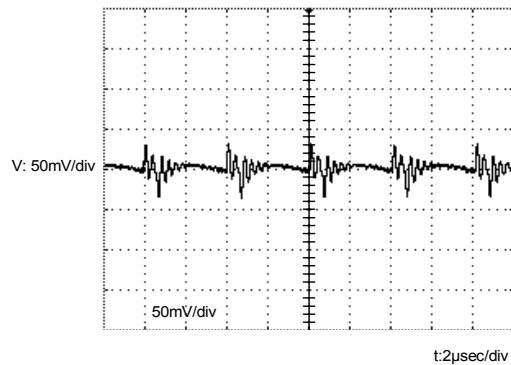

Test conditions: Rating input/Rating load/Room temperature

VSA24-12S0R6

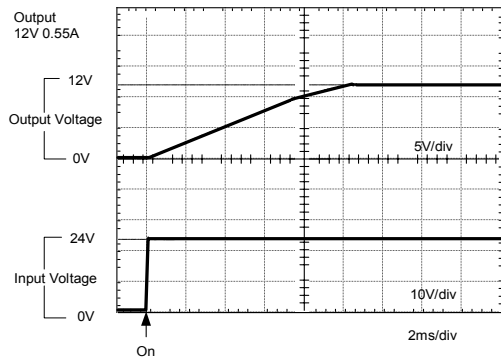

Test conditions: Rating input/Rating load/Room temperature

VSA24-12S0R6

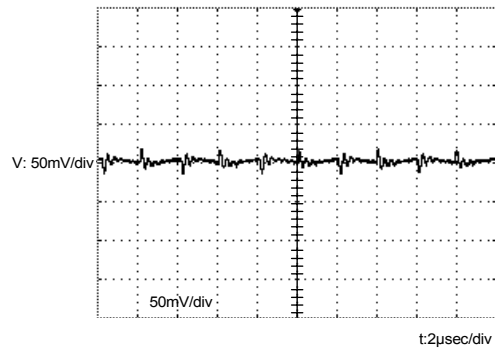

Test conditions: Rating input/Rating load/Room temperature

<Temperature derating>

Please set this products at good place for the convection.
 As to Temperature derating and air condition, please see the below.

Cooling Condition : Natural Air Cooling

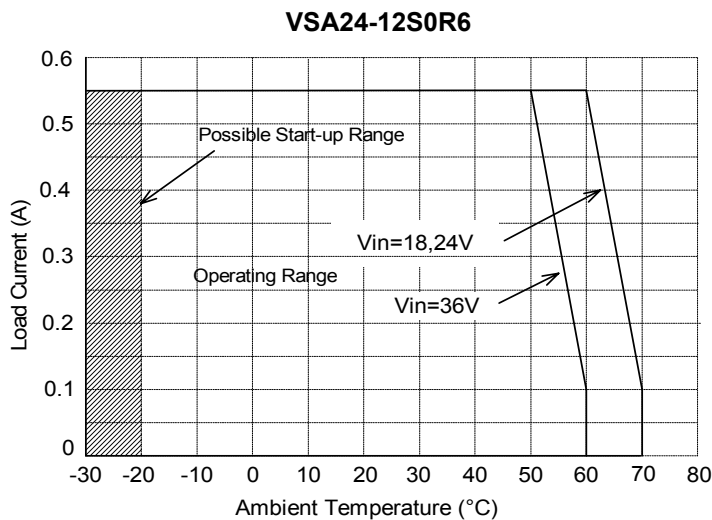
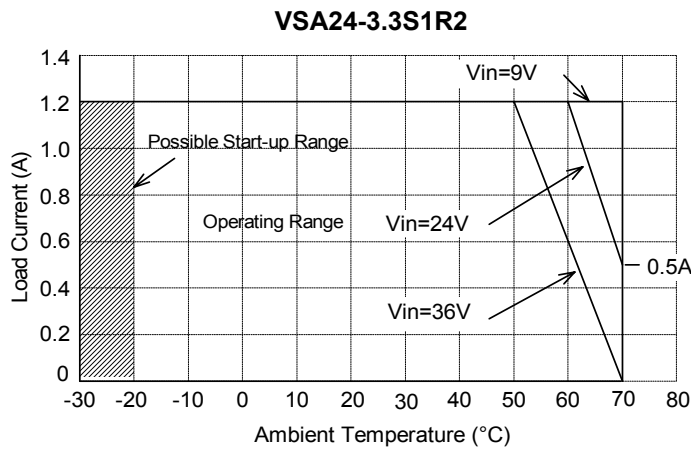
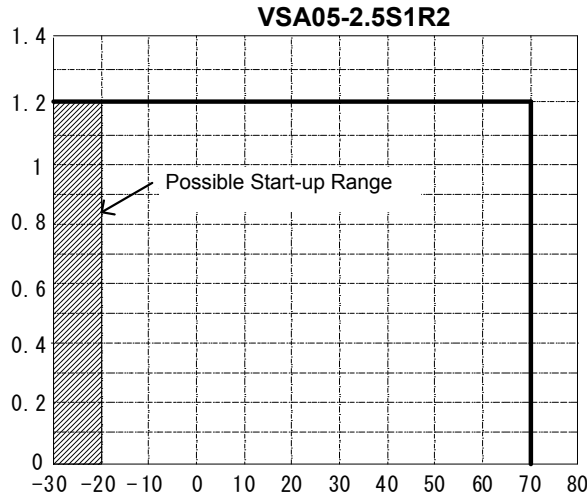

<Over-Current Protection>

This model has a built-in over-current protection circuit (operating at rating 105% or more), and protects against the output over-current.

It will automatically recover by releasing the over-current condition. Please avoid keeping long-time over-current or output short-circuit condition, it may cause converter's failure. For a protection in case a large current flows into the input, caused by the converter's failure, be sure to connect a fuse to the input +line.

VSA05 Series

1) Over-Current Protection

The over-current characteristics are as you can see in figure 7, and will automatically recover by releasing the over-current condition. However, when the load impedance comes close to 0 and the current grows, the latch circuit may operate. When the latch circuit operates, release the over-current condition and restart the input.

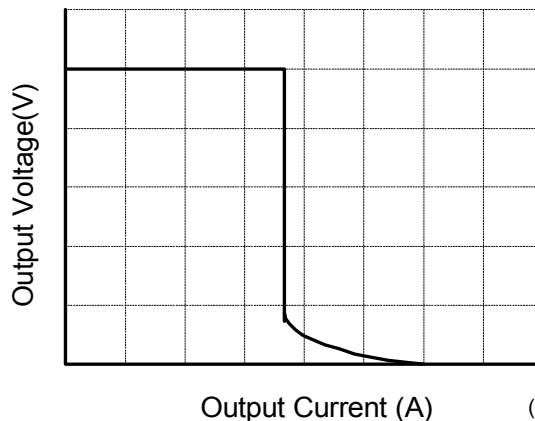

(Figure 7)

2) Output Short-Circuit Protection

The over-current protection will also operate when the output is short. However, when the output suddenly goes short, or restart the input when the output is still short, a very large current will flow into the converter momentarily and the over-current point may grow due to the short-circuit current.

For a protection in case the output goes short or the load failure causes an output short-circuit condition, be sure to connect a fuse.

VSA24 Series

The over-current characteristics are as you can see in figure 8, and will automatically recover by releasing the over-current condition.

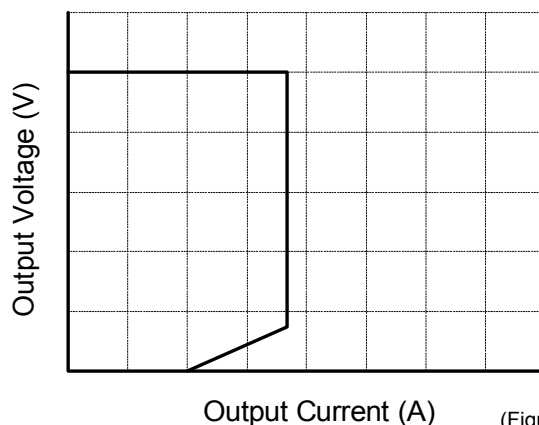

(Figure 8)

<Reverse Bias Protection Between Output Pin and GND Pin>

VSA05 Series

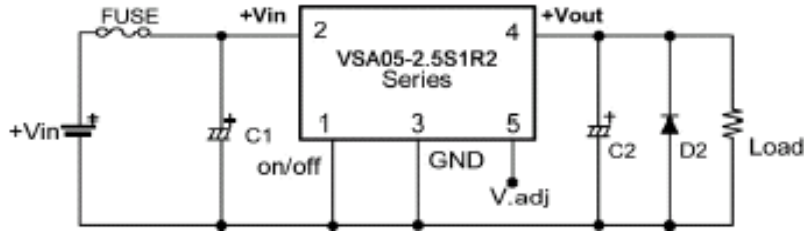

(Figure 9)

For this VSA05 series, at turn-off transient of output, a negative voltage will occur in the output due to the reverse current flowing in from the output additional capacitor into the coil inside the converter. To keep the voltage low, connect the low schottky diode (D2) of Vf between +Vout and GND.

VSA24 Series

A diode for reverse bias protection between the output pin and GND pin is not required.

<Soldering Conditions>

Solder to be executed under the following conditions.

1. Hand Soldering Condition 340°C to 360°C within 5sec.
2. Wavesoldering Condition 240°C to 260°C within 10sec.

<Cleaning Conditions>

This product can not be cleaned bodily and is recommended non-cleaned flux. When and if cleaning only for SIP and DIP type should be necessary, use IPA and hand-wash the soldered surface by brush cleaning.

After cleaning, please dry enough to use it.

<To prevent reverse input voltage protection (ex.)>

The input/output of this products is a non-isolated type and a step-down DC-DC converter from (+) polarity to (+) polarity. If you connect the input polarity reversed of this product by mistake it will be eventually damaged. If there is a possibility of reverse connection, please add a protection circuit as indicated in the following figure. The figure below is an example using fuse and diode.

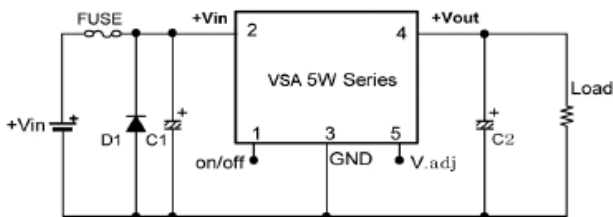

(Figure 7)

<Over-Voltage Protection (ex.)>

This product does not have a built-in over-voltage protection.

When the switching element of this converter gets damaged by short mode, input voltage (+Vin) will go out on the output.

For emergency if it gets damaged at over-voltage mode, please add a circuit as below to intercept the supplying power circuit.

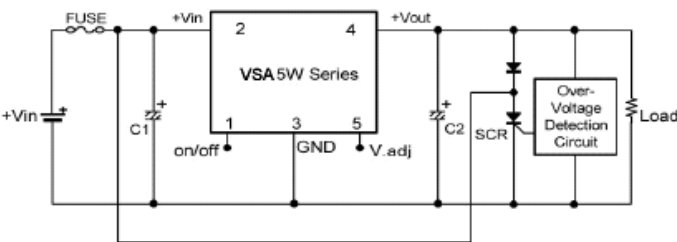

(Figure 8)

Notes:

- 1 When it is damaged at over-voltage mode, ON/ OFF control does not operate.
- 2 When there is a DC Power Supply on the supplying power side, please have the capacity the fuse can be cut.

<Directions>

For customer's safety, please see the specification and obey the undermentioned notes definitely when using this product.

- This product intends to be used for a general electronic equipment (Clerical work machine, Telecommunications equipment, and Measurement equipment). Please do not use the medical equipment, the nuclear power equipment, and the train, etc. with dread that the damage of this product might influence the life and the property directly. Please confirm us when you use except for the general electronic equipment.
- This product cannot be driven with parallel and series.
- Please use neither connector nor the socket to mount this product. The performance might not be able to be satisfied because of the contact resistance. Please execute mounting on the printed wiring board by soldering.
- Although the overcurrent and the short-circuit protection circuit are built in this product, please avoid short-circuit for a long time as it causes the breakdown.
- There is a possible to be damaged for this product if it is used in a non-standard electric condition and an environmental condition etc. of the temperature etc. Please use it in the standard.
- Please make the earth electrical discharge done, and work about worker's electrified static electricity which might be damaged by static electricity in the environment static electricity.
- This product does not built the fuse inside. When it is abnormal, please connect the fuse with + input line as protection for an excessive current flows to the input. Please give capacity by which the fuse can be cut to the power supply.
- This product does not built in the overvoltage protection.
- When the overvoltage is abnormally generated in the module, there is a mode that the input voltage appears to the output straight, and causes smoking and the ignition. Please add the overvoltage protection circuit to prevent it.
- The examination result is not attached to this product.

<Guarantee>

The guaranteed term of this product is one year. During this period, if there should be any failure definitely due to our designing or manufacturing workmanship, we will repair or replace with new one at our own expense. But in that case that you should modify and / or make internal remodeling by itself whatsoever, we cannot guarantee it.

This guarantee shall cover only 5 Watt VSA series.

<Others>

We will decide upon both deliberations when the doubt is caused in this catalog.