

Current Sense
Application Note
Resistors

BI Technologies IRC Welwyn

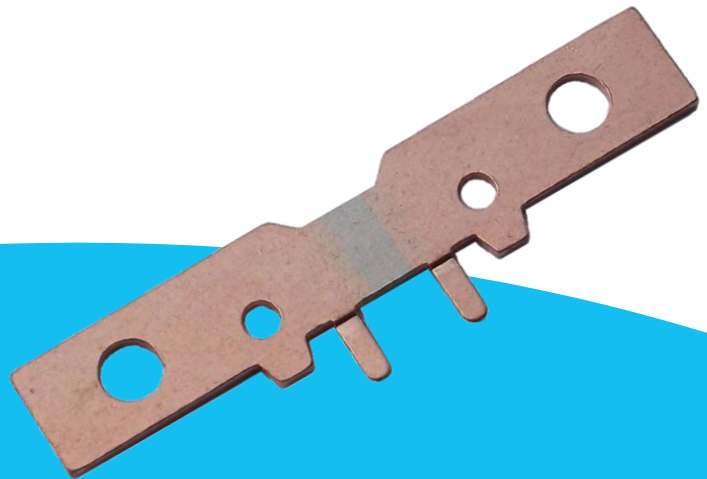

Application Note

Current Sense Resistors

The need to measure the flow of current in electronic systems is becoming increasingly widespread. Reasons for this include the growth of battery-powered portable products, increasing concern to minimise energy usage, and the spread of electrically actuated systems in cars.

In this context, measuring a current means converting it to a voltage, which may then be compared with a threshold, digitised or otherwise processed by a current sense circuit. There are several solutions for doing this, including current transformers, Hall-effect sensors and magnetoresistive sensors. However, the simplest and, in many cases, lowest cost method is to employ Ohm's law in the form of a current sense resistor.

There are two problems traditionally associated with using a resistor to measure current. The first is the power dissipation at high currents - even a $1\text{m}\Omega$ resistor dissipates 10W at 100A . The second is the lack of electrical isolation between the high current path and the sense circuit. Advances in interface circuits, which can offer both high sensitivity and isolation, can tackle both of these problems.

TT Electronics offers a large range of standard resistive current sense products. In addition to this, TT Electronics has many years of experience in adapting or designing components to meet the requirements of specific current sense applications.

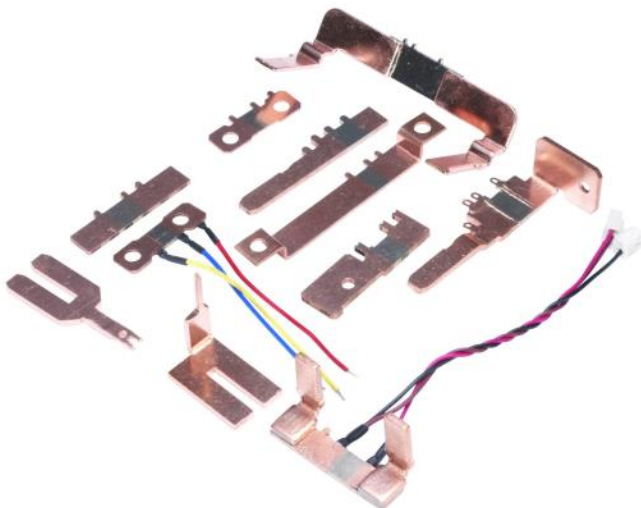

Application Note

Battery Charger

Portable, battery powered equipment is a rapidly expanding product area. The drive for more features and less frequent re-charging has led to lithium-ion becoming the preferred technology, with its superior energy density. The task of charging a lithium-ion battery is, however, more demanding

than for earlier types. This has given rise to the development of charger controller IC's, which regulate the current and voltage within the tight limits required. A typical charging current is 500mA, so a 200mΩ resistor will give 100mV signal with negligible power dissipation. An LR1206-R20, available to 1%, is a suitable choice.

BATTERY CHARGER

HOT-SWAP CONTROLLER

Low Value Flat Chip Resistors LR Series

- Resistance values down to 0.003 ohms
- Leach resistant solder plated copper wrap around termination
- Low inductance - less than 0.2nH

Hot Swap Controller

Microprocessor-based boards require power supply rails of high integrity, even under extreme conditions such as removal from and insertion into a live backplane. This may be achieved using a hot-swap controller IC, which regulates the ramp-up of the supply rail on the plug-in card and protects against accidental shorts.

This calls for sensing of the current, which may be several amps, depending on the requirements of the plug-in module. For example, a 5A current limit with a 5mΩ resistor gives a 25mV trip level and dissipates up to 125mW. An LRF2010-R005 is ideal here.

Example Products

LR

- Thick-film
- Low temperature rise
- 1206 to 2512

LRCS

- Thick-film
- Compact size
- 0402 to 0805

LCS

- Thin-film
- Precision
- 0.5% & 50ppm/°C

MFC

- Metal foil
- High stability
- Up to 5W rating

Application Note

Medium Current Applications

One of the most cost sensitive areas for the application of current sense resistors is in power supply modules for the telecoms and IT sector. The currents involved may be higher than can be handled by a chip resistor, but high-frequency performance is still important. Low inductance metal element resistors are the ideal solution here.

The circuit below shows one example of a power supply application. It is a linear regulator with current foldback limiting. As the foldback limit is reached, the voltage across R_{SENSE} switches T₂ on, which diverts the base current of T₁. This overrides the voltage regulation, and the circuit operates in constant current mode.

Power Supply Current Limiting

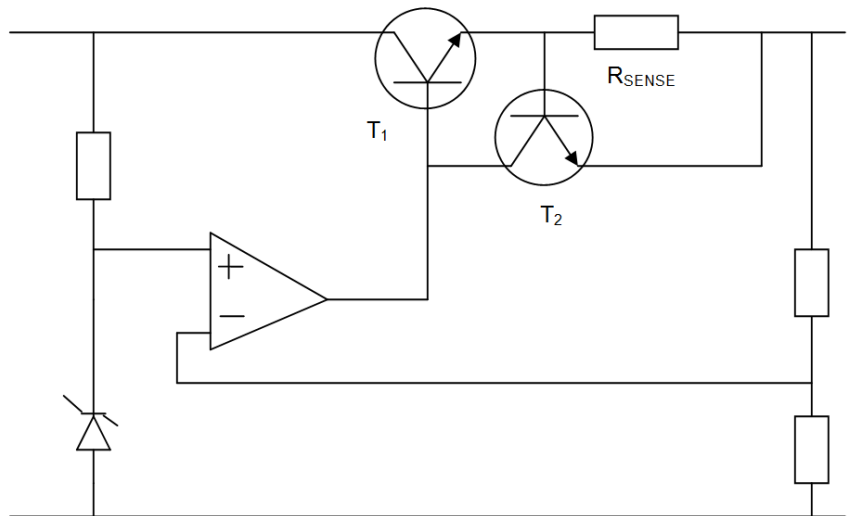

Example Products

OAR

- Metal element
- High surge
- Up to 5W rating



OARS

- SMD version of OAR
- Flexible terminations
- Heat away from PCB



LRMA

- Metal element
- Wide rating & value range
- Up to 3W in 2512

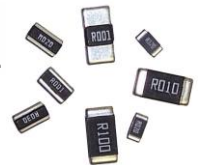

ULR

- Metal element
- Values to 150μΩ
- Up to 3W rating



Application Note

High Current Applications

The availability of extremely low value sense resistors combined with opto-isolated amplifiers such as Broadcom's HCPL-788J now presents a real alternative to using expensive Hall-effect sensors in the sub-60A range. This is of particular importance in the area of motor control, where isolation from the mains supply is essential. Opto-isolated resistive current sensing can also give benefits

over Hall-effect sensors in terms of temperature stability, linearity and, with careful layout design, common mode rejection.

An example of such a circuit is shown below.

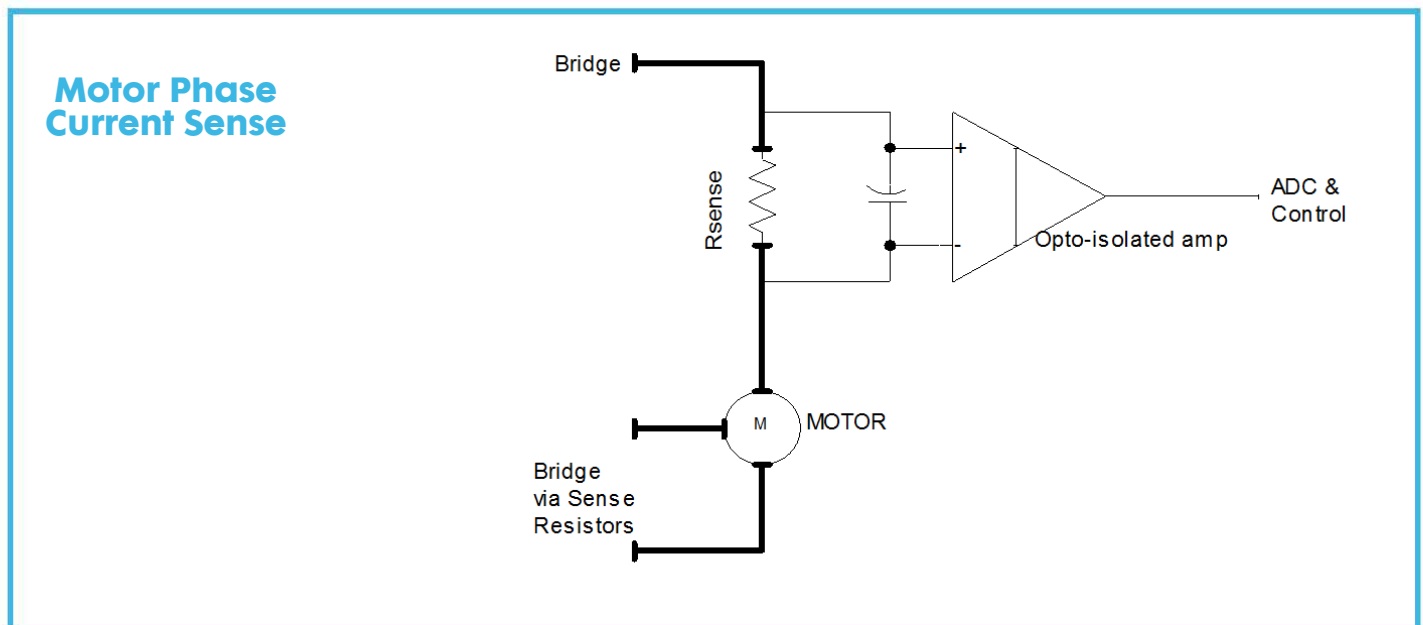

The important attributes in this case are the availability of values below $10\text{m}\Omega$, up to 5W power rating with good surge withstand ability and low inductance. The ideal choice for RMS phase currents up to the practical current limit of FR4 PCBs is the LRMAP3920, which is a metal element chip with a rating of 5W on

FR4 and 10W on thermal substrates. For higher currents extending into hundreds of amps, busbar mounting is normally used. For such assembly methods, the electron-beam welded EBW series is custom designed to accommodate the termination format required for each installation.

Example Products

LRMAP3920

- Metal element
- High surge to 14J
- Up to 10W rating
- Values $200\mu\Omega$ to $3\text{m}\Omega$
- AEC-Q200



EBW

- Metal element
- Electron-beam welded
- Typically 25 to $500\mu\Omega$
- Custom designed format
- High stability



Application Note

1. Value

To minimise power loss, choose the minimum suitable resistance value. This is the lowest value of peak sense voltage consistent with an acceptable signal to noise ratio, divided by the peak current to be measured. Current sense resistors are generally available at integer milliohm values up to R01 and at multiples of 5 milliohms above this, in addition to standard E24 values.

2. Rating

Calculate the power dissipation under operating conditions ($I_{RMS}^2 \cdot R$). Allowing for transient or fault conditions and high ambient temperature if applicable, select the required power rating. For many current sense products, only the maximum temperature of the solder joints limits the power rating. Power rating is thus a function of the PCB layout design as well as of component selection (see point 4.).

3. Tolerance & TCR

Establish the accuracy needed in terms of a tolerance on the value and of sensitivity to temperature. The latter factor is quoted as Temperature Coefficient of Resistance (TCR), defined as the value change in parts per million for a 1°C temperature rise. It is generally higher for low value resistors because the metallic leads or terminations, which have a very high TCR, make up a significant part of the total resistance value. To achieve acceptable accuracy it is normally necessary to make four-terminal (Kelvin) connections to the resistor. This means connecting the current carrying tracks and the voltage sense tracks directly to the component pads. Even when this is done, there is still some pad area and solder in series with the resistor, which may compromise the actual tolerance and TCR of the soldered part. For very high accuracy or very low values, a four-terminal resistor type should be chosen.

4. Layout

Care must be taken when laying out a PCB if the stated performance of a sense resistor is to be achieved. The current carrying tracks should be as wide as possible, using multiple layers connected by many vias near the component pad. This also improves the heatsinking of the joints.

The best way to make four-terminal connections to a two terminal through-hole resistor is to use different sides of the PCB for the current and voltage connections. Failing this, current and voltage tracks should connect to opposite sides of the component pad.

In order to avoid interference from stray magnetic fields, the loop area contained by the sense resistor, the voltage sense tracks and the sense circuit input should be minimised. This means keeping the sense circuitry as close as possible to the sense resistor and running the voltage sense tracks close to each other, or, better still, superimposed in different PCB layers.

5. Inductance

Where transient or AC currents involving high frequencies are to be sensed, the self-inductance of the resistor must be minimised. Wirewound or spiralled film parts should be avoided, in favour of bulk metal or low value chips. For example, the LR series chip resistors have inductance values below 200pH.

6. Thermal EMF

When using a metallic element shunt with high heat dissipation and low sense voltage, consideration may need to be given to thermoelectric voltages. The junction between a metallic resistance element and metal terminations acts as a thermocouple, generating a voltage proportional to the temperature difference across it. A metal element sense resistor is therefore like two thermocouples back to back. This means that, if the temperature differences across both junctions are equal, the error voltage is cancelled out. This is achieved by making the design thermally symmetrical, that is, by presenting both terminals with similar heatsinking and by keeping any other heat sources thermally distant.

A further benefit may be obtained by choosing an alloy with an inherently low thermal EMF against the termination material. For example, a manganin - copper junction develops just $3\mu V/^\circ C$ which is over an order of magnitude lower than for a copper nickel alloy.

Application Note

Series	Description	Mounting	Package	Technology	Rating	Resistance	Precision	Approvals
 CSL	Four-terminal open air	Through hole	Radial	Metal element	5W	0.25-2.5mΩ	1 % 55ppm/°C	None
 EBW	Electron-beam welded shunts	Busbar	Custom	Metal element	1-10W typ.	25-500μΩ typ.	1 % 50ppm/°C	N/A
 LCS	Low value Thin film chip	SMD - solder	Chip 0603-2152	Metal film	0.1-1W	0.2-1Ω	0.5 % 50ppm/°C	None
 LOB	Low resistance metal element	Through hole	Axial	Metal element	1-5W	5-100mΩ	1 % 40ppm/°C	None
 LR	Low value flat chip	SMD - solder	Chip 1206-2512	Thick film	0.5-2W	3mΩ-1Ω	1 % 100ppm/°C	AEC-Q200
 LRCS/LVC	Low value surface mount chip	SMD - solder	Chip 0402-0805	Thick film	63-250mW	20mΩ-1Ω	1 % 200ppm/°C	None
 LRF3W	Low value 3W chip	SMD - solder	Chip 1225	Thick film	3W	3-100mΩ	1 % 100ppm/°C	AEC-Q200
 LRMA	Low resistance metal alloy	SMD - solder	Chip 0805-2512	Metal element	0.5-3W	0.5-300mΩ	1 % 75ppm/°C	AEC-Q200
 LRMAP 3920	Low resistance metal alloy power	SMD - solder	Chip (other size)	Metal element	5W	0.2-3mΩ	1 % 50ppm/°C	AEC-Q200
 MFC	Metal foil on ceramic chip	SMD - solder	Chip 0603-2817	Metal foil	0.5-5W	5-150mΩ	1 % 50ppm/°C	None
 OAR	Open air resistor metal element	Through hole	Radial	Metal element	1-5W	3-100mΩ	1 % 20ppm/°C	DSCC
 OARS	Surface mount sense	SMD - solder	SMD formed terminal	Metal element	2-3W	2-50mΩ	1 % 20ppm/°C	AEC-Q200
 OARSXP	Surface mount sense	SMD - solder	SMD formed terminal	Metal element	5W	1-25mΩ	1 % 20ppm/°C	AEC-Q200
 PLO	Low resistance power wirewound	Through hole	Ceramic case power	Metal element	3-15W	10-180mΩ	1 % 30ppm/°C	None
 PWRL	Radial wirewound	Through hole	Radial	Metal element	3-10W	10-180mΩ	1 % 50ppm/°C	None
 ULR	Metal element current sense	SMD - solder	Chip 1206-2512	Metal element	1-3W	0.15-22mΩ	1 % 50ppm/°C	AEC-Q200

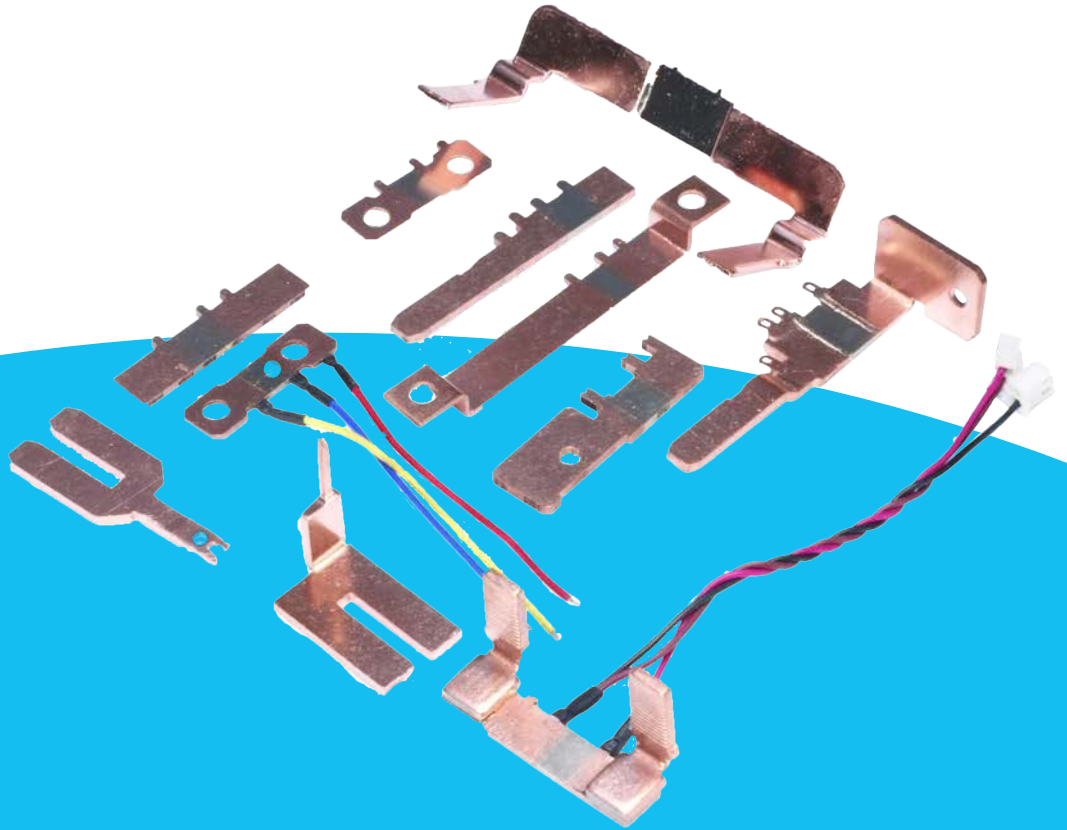

www.ttelectronics.com/resistors

TT Electronics, 4222 South Staples St., Corpus Christi, TX 78411, USA

TT Electronics, Welwyn Electronics Park, Bedlington, Northumberland, NE22 7AA, UK

General Note TT Electronics reserves the right to make changes in product specification without notice or liability. All information is subject to TT Electronics' own data and is considered accurate at time of going to print.