

CPC5622

LITELINK™ III Phone Line Interface IC (DAA)

CLARE
An IXYS Company



Description

LITELINK™ III is a single-package silicon phone line interface (PLI)/ Data Access Arrangement (DAA) used in voice and data communication applications to make connections between host equipment and telephone networks.

The CPC5622 is the latest LITELINK III PLI device that features simultaneous phone line ringing detect and Caller-ID (CID) monitoring. This eliminates additional discrete components thereby simplifying the DAA design particularly for international telephony applications where CID occurs before ringing. In addition, the CPC5622 offers both half-wave and full-wave ringing detect outputs to support most codec, DSP and modem devices.

LITELINK provides a high-voltage isolation barrier, AC and DC phone line termination, switch hook, 2-wire to 4-wire hybrid, ringing detection, and on-hook signal detection.

LITELINK can be used in both differential and single-ended signal applications. LITELINK uses on-chip optical components and external resistors to form a complete voice or high-speed data phone line interface. LITELINK eliminates the need for the large isolation transformers or capacitors used in other interface configurations and incorporates the required high-voltage isolation barrier in the surface-mount SOIC package.

CPC5622 Block Diagram

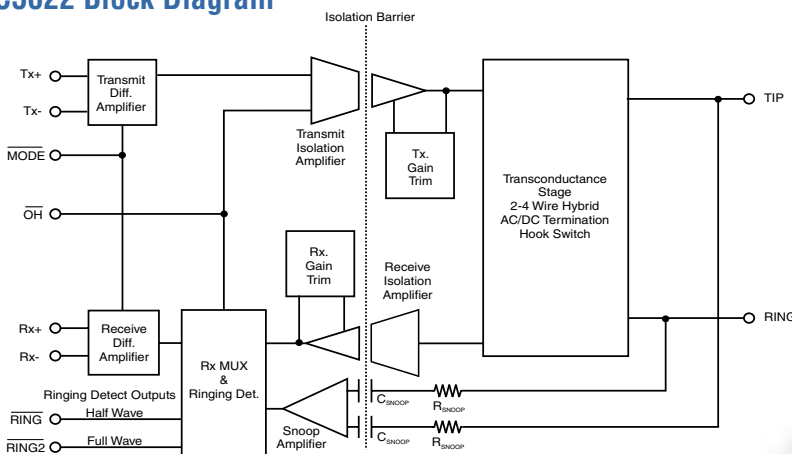

Features

- Concurrent ringing detection and Caller-ID monitoring for worldwide applications
- Half-wave and full-wave ringing detection are provided on the CPC5622
- New 3kV_{rms} internal isolation voltage barrier
- Superior voice solution with low noise, excellent part-to-part gain accuracy
- Very low 8mA line-side current draw
- Transmit power of up to +6 dBm into 600Ω
- Data access arrangement (DAA) solution for modems with speeds up to V.92
- 3.3 or 5V power supply operation
- Caller-ID signal reception function
- Easy interface with modem ICs and voice CODECs
- Programmable AC termination impedance for global applications with select voice codec partners
- Worldwide dial-up telephone network compatibility
- CPC5622 can be used in circuits that comply with the requirements of TIA/EIA/IS-968 (FCC part 68), UL1950, UL60950, EN60950, IEC60950, EN55022B, CISPR22B, EN55024, and TBR-21
- Line-side circuit powered from telephone line
- Compared to other silicon DAA solutions, LITELINK:
 - Uses fewer passive components
 - Takes up less printed-circuit board space
 - Uses less telephone line power
 - Offers simplified operation
 - Is a single IC-solution

Applications

- Computer telephony and gateways, such as VoIP
- PBXs
- Satellite and cable set-top boxes
- V.92 (and other standard) modems
- Fax machines
- Voicemail systems

LITELINK III Evaluation Board and Reference Design

Clare provides a complete telephone line interface/DAA with LITELINK III. The LITELINK III family of products includes:

- CPC5602 FET optimized for use with LITELINK III
- CPC5601 programmable driver for setting multiple AC and DC terminations with one circuit
- Complete reference designs including modem and FXO

Visit the Clare web site for more information on the complete LITELINK III solution, including application notes covering:

- Loop current detection with LITELINK
- Customizing Caller-ID signal gain and ringing signal detection threshold
- Enhanced pulse dialing with LITELINK
- Design layout guidelines to help meet regulatory requirements
- Increased LITELINK transmit power
- Ground start supervision circuit
- Updating current LITELINK II designs to LITELINK III
- Understanding LITELINK Display Feature Signal Routing and Applications



LITELINK III Resistive Termination Reference Design Schematic

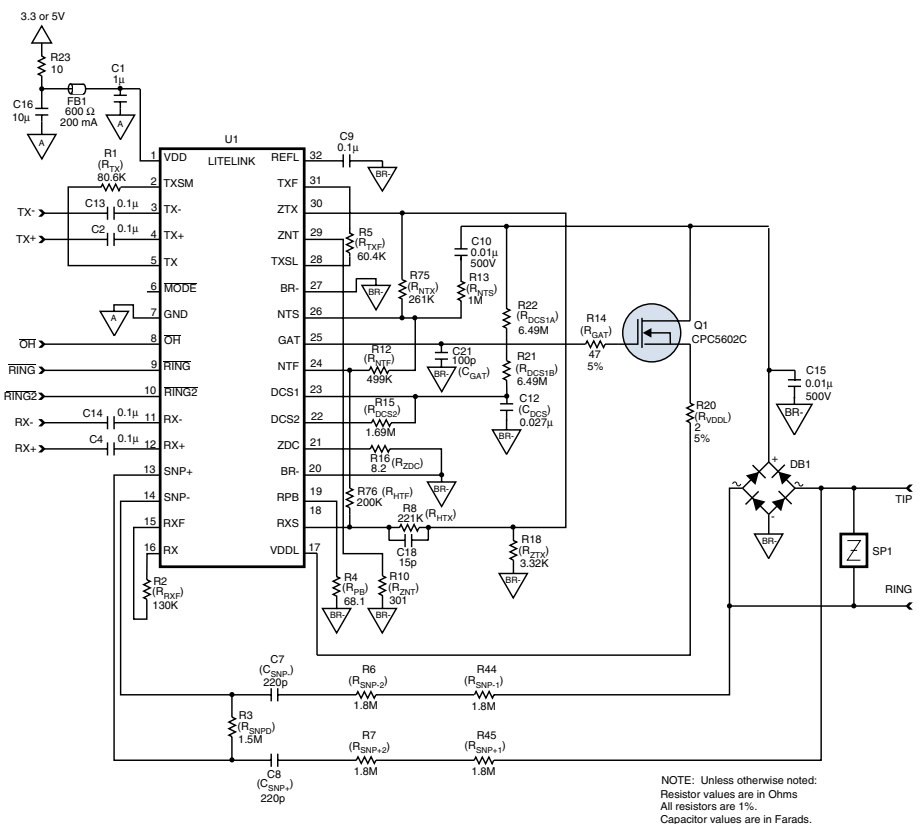

Clare
78 Cherry Hill Drive
Beverly, MA 01915
Tel: 978-524-6700
Fax: 978-524-4700
Web: www.clare.com

Ordering Information

Part #	Description
CPC5622A	32-pin PLI, tubed
CPC5622ATR	32-pin PLI, tape and reel