

USB UART BOARD DESIGN CONSIDERATIONS FOR USB COMPLIANCE

1.0 INTRODUCTION

The XR21V1410, XR21V1412 and XR21V1414 USB UARTs have passed compliance for USB 2.0 Full-Speed and are listed on the USB-IF Integrator’s List. This application note describes some scenarios to consider when designing a commercial product using the XR21V141x to ensure that it has a higher possibility of passing USB compliance.

2.0 DESIGN CONSIDERATIONS

The first design option to consider is whether the commercial product will be a self-powered or bus-powered design.

In a self-powered design, an alternative power source is supplied via a power jack or battery to the USB UART and other components on the board (See **Figure 1**). Design considerations for a self-powered design are discussed in Section 2.1.

In a bus-powered design, the 5V from the VBUS of the USB connector (from the USB host) provides power source for the USB UART and possibly other components on the board (See **Figure 2**). Design considerations for a bus-powered design are discussed in Section 2.2.

2.1 Design Considerations for Self-Powered Applications

This section discusses the various design considerations for a self-powered application to ensure that it will pass USB compliance. A typical block diagram for a self-powered application is shown in **Figure 1** below (UART channels are not shown).

FIGURE 1. TYPICAL BLOCK DIAGRAM FOR SELF-POWERED APPLICATIONS

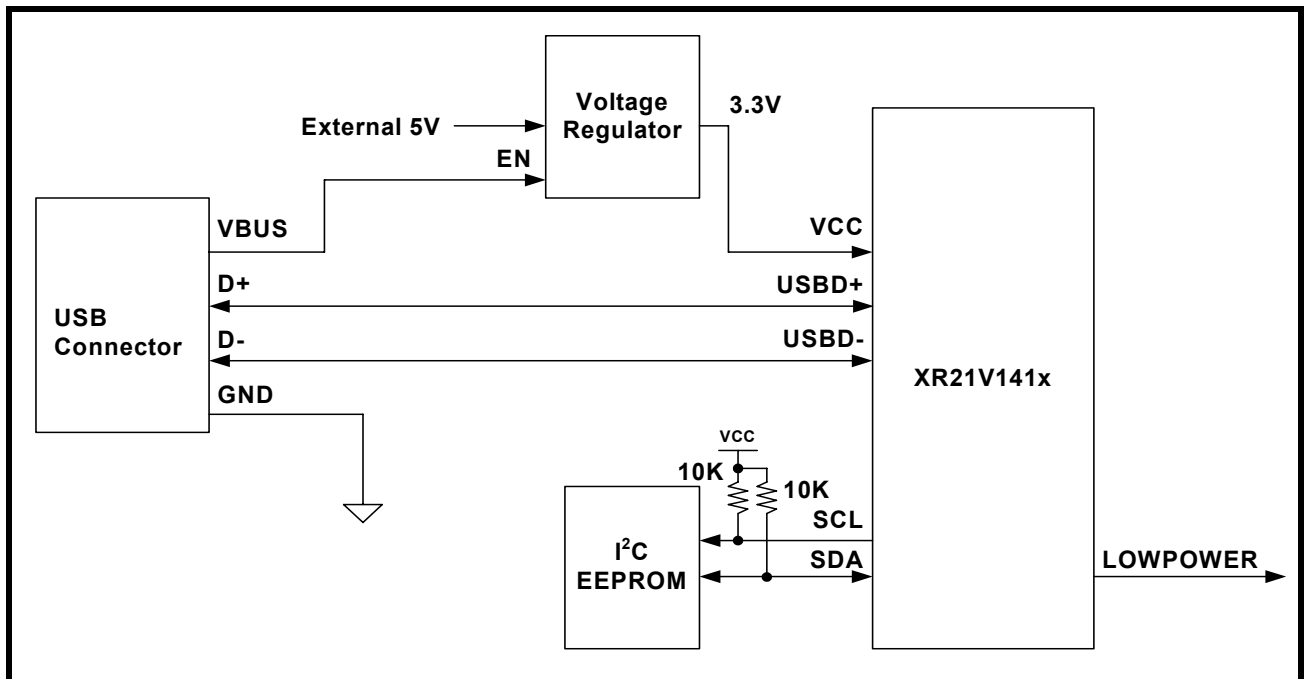

AN202

2.1.1 VBUS

Even though the design is self-powered and does not need power from VBUS, it may still be needed for USB compliance. According to the USB Compliance Checklist (version 1.08), it is recommended that the XR21V141x should only signal that it is connected when there is power on VBUS. For that to happen, power to the XR21V141x must be disconnected or turned off. One way to do this is to use the VBUS to disable power to the XR21V141x. If using a voltage regulator, the VBUS can connect directly to the ENABLE pin to enable/disable the voltage regulator.

2.2 Design Considerations for Bus-Powered Applications

This section discusses the various design considerations for a bus-powered application to ensure that it will pass USB compliance. A typical block diagram for a bus-powered application is shown in Figure 2 below (UART channels are not shown).

FIGURE 2. TYPICAL BLOCK DIAGRAM FOR BUS-POWERED APPLICATIONS

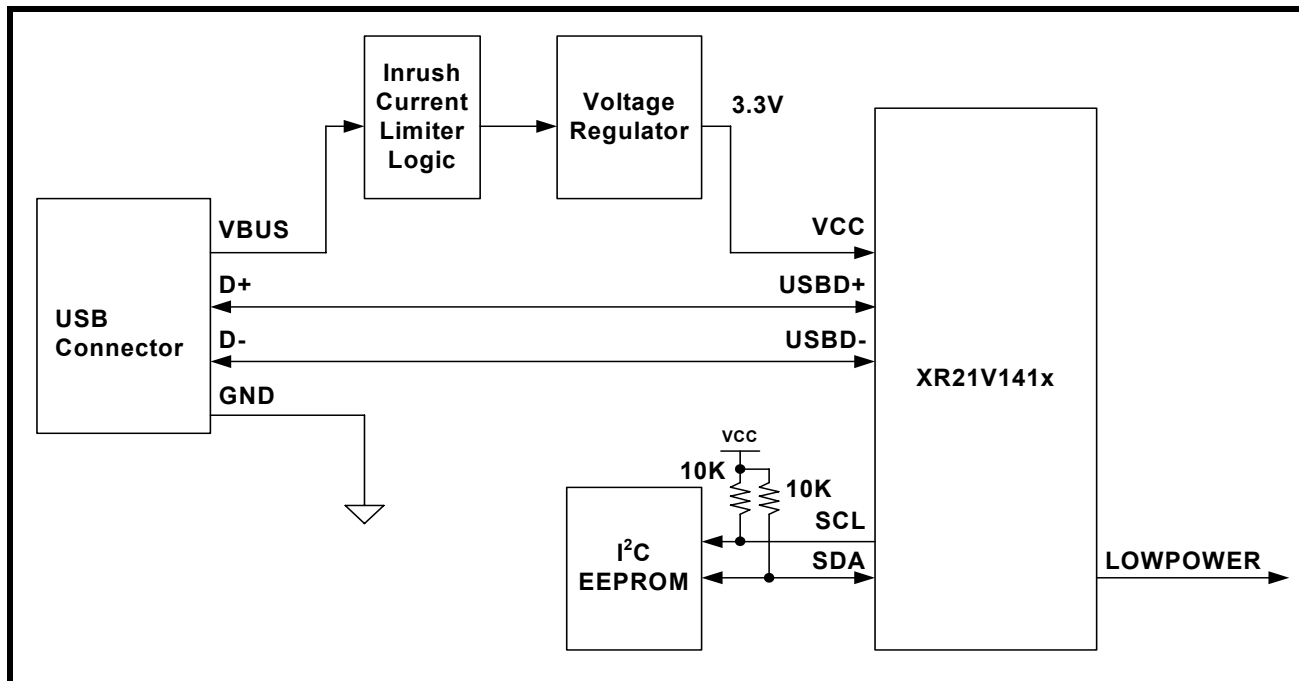

2.2.1 VBUS

The VBUS signal from the USB connector (host) provides 5V power. The XR21V141x is a 3.3V device. Therefore, a voltage regulator is required to regulate the 5V signal down to 3.3V. Voltage regulators are available from Exar. An example of a cost-efficient LDO that can be used is the SP6260 which provides a guaranteed 150mA output current.

2.2.2 Inrush Current

The inrush current measures how much power the commercial product draws when it is connected to a USB host/hub. According to the USB 2.0 specifications, the inrush current needs to be limited to 100 mA/μs in order to prevent the surge of current into the board from pulling the VBUS on the hub below its minimum operating level. To minimize the amount of inrush current, an inrush current limiter is recommended and the bypass capacitance on the VBUS signal should be limited to 10μF. An example of an inrush current limiter can be found in the XR21V141x evaluation board schematics.

2.2.3 Suspend Mode Current

According to the USB specification, all USB devices must support the Suspend Mode. Typically, a Start-Of-Frame (SOF) packet is sent by the USB host/hub to a Full-Speed USB device like the XR21V141x every 1ms whether there is any data to send or not. When the XR21V141x does not see a Start-of-Frame (SOF) packet for more than 3ms, the XR21V141x enters a low power Suspend Mode.

2.2.3.1 Maximum Suspend Current

The USB 2.0 April 2000 specifications listed a maximum suspend current of 500uA for bus-powered products. However, in April 2008, an ECN was issued increasing the maximum suspend current of bus-powered commercial products (XR21V141x and all of the other components on the board) to 2.5mA. Therefore, it is recommended that the other components on the board have low power or shutdown modes to minimize the power consumption.

2.2.3.2 LOWPOWER Output Pin

The LOWPOWER pin on the XR21V141x can be used as a control signal to enable/disable other devices in the design. The LOWPOWER pin is sampled as an input momentarily at power-up and at bus reset and will be active high if a pull-up resistor (10K ohms) is present upon power-up or active low if there is a pull-down resistor (3.3K ohms) at power-up. When the XR21V141x enters the suspend mode, the LOWPOWER pin will be asserted so that the other devices can also enter into their low power mode. Exar offers many RS-232 and RS-485 transceivers that have a shutdown mode that minimizes the power consumption.

2.3 External EEPROM

An external I²C EEPROM can be used to specify various USB configuration values such as the Vendor ID, Product ID, Device Attributes, and Maximum Power consumption. The configuration values must be programmed correctly or the design will fail USB compliance. Pull-up resistors (10K ohms) are required on the SDA and SCL lines in order for the XR21V141x to attempt to read the values from the external I²C EEPROM.

2.3.1 Vendor ID and Product ID

According to the USB-IF website, the Vendor ID of the commercial product must match the Vendor ID that was assigned by the USB-IF. The commercial product will not be listed on the Integrator's List if the Vendor ID does not belong to the Integrator. In other words, Exar's default Vendor ID can not be used in a commercial product that needs to be certified. The only way to obtain a unique Vendor ID is to contact the USB-IF (www.usb.org). There will be fees associated with obtaining the Vendor ID.

2.3.2 Device Attributes

The Device Attributes lets the USB host/hub know whether the commercial product with the XR21V141x is bus-powered or self-powered and whether it has support for Remote Wakeup capability.

2.3.2.1 Bus-Powered or Self-Powered

The USB host/hub needs to know if the commercial product needs power from the USB host/hub or not. If the USB host/hub determines that it does not enough power for all of the devices connected to it, then some devices will not receive any power until there is enough power available (ie. one or more of the USB devices have been removed from the USB host/hub).

2.3.2.2 Remote Wakeup

The XR21V141x has support for Remote Wakeup. In order for Remote Wakeup to function properly:

- The Remote Wakeup feature needs to be enabled and
- The software driver will need to have support for Remote Wakeup

If the XR21V141x reports in the USB descriptors that it can support Remote Wakeup (programmed via the EEPROM), but the software driver does not support Remote Wakeup, the commercial product will not pass USB compliance.

For a custom driver that supports Remote Wakeup, send an e-mail to uarttechsupport@exar.com.

AN202

2.3.2.3 *Maximum Power Consumption*

As mentioned in the previous section, the maximum power consumption is used by the USB host/hub to determine how much power a commercial product needs. A low power device can request up to 100mA. If more than 100mA is needed for normal operation, then it is considered a high power device and can consume up to 500mA. However, high power devices must power-up in low power mode when it is unconfigured (driver has not been loaded). The device can only enter the high power mode once the USB host/hub determines that the power requested is available for the device (and allows the OS to load the driver). If the commercial product consumes more power than it has specified, then it will not pass USB compliance.

3.0 TECHNICAL SUPPORT

Technical questions about this application note, the XR21V141x, evaluation boards, or software drivers should be e-mailed to uarttechsupport@exar.com.

NOTICE

EXAR Corporation reserves the right to make changes to the products contained in this publication in order to improve design, performance or reliability. EXAR Corporation assumes no responsibility for the use of any circuits described herein, conveys no license under any patent or other right, and makes no representation that the circuits are free of patent infringement. Charts and schedules contained here in are only for illustration purposes and may vary depending upon a user's specific application. While the information in this publication has been carefully checked; no responsibility, however, is assumed for inaccuracies.

EXAR Corporation does not recommend the use of any of its products in life support applications where the failure or malfunction of the product can reasonably be expected to cause failure of the life support system or to significantly affect its safety or effectiveness. Products are not authorized for use in such applications unless EXAR Corporation receives, in writing, assurances to its satisfaction that: (a) the risk of injury or damage has been minimized; (b) the user assumes all such risks; (c) potential liability of EXAR Corporation is adequately protected under the circumstances.

Copyright 2009 EXAR Corporation

Datasheet December 2009.

Send your UART technical inquiry with technical details to hotline: uarttechsupport@exar.com.

Reproduction, in part or whole, without the prior written consent of EXAR Corporation is prohibited.
