



Glass Sealed Ultra-High Value Resistors

Application Note

Resistors

BI Technologies IRC Welwyn



Application Note

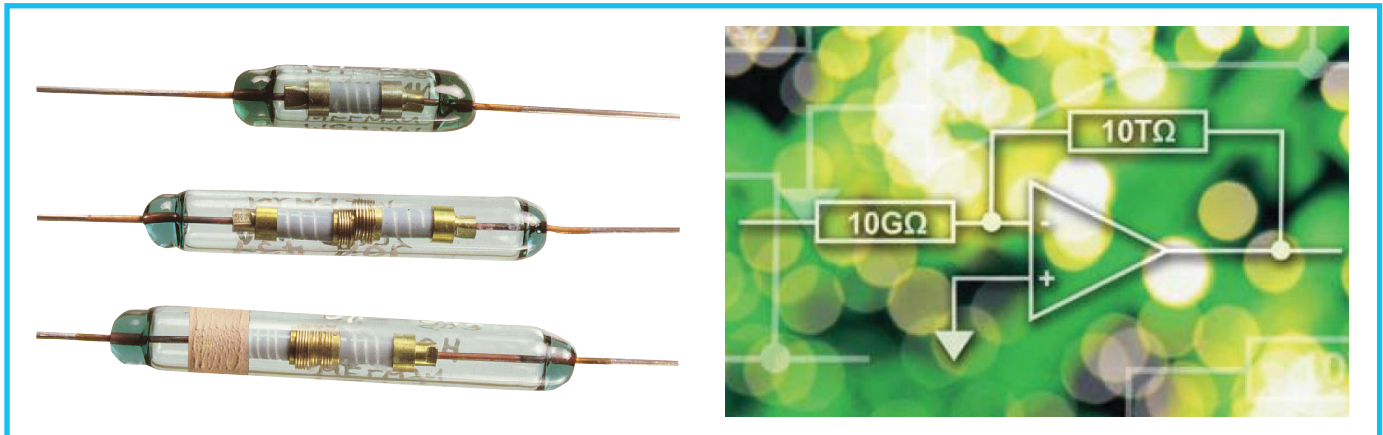

Guard Band Principle

When a leakage path exists between two terminals it is nearly always possible to nullify the leakage by interposing a metallic electrode between the two terminals. Although leakage currents may continue to flow, it is possible to divert the leakage current from a critical electrode to some other point in the circuit where its effect is negligible. In many cases, for example in an inverting amplifier, it is sufficient to connect the guard band to ground potential. In

other cases, for example in a “follower” type of amplifier, it may be necessary to drive the guard from the output of the amplifier. Details of these circuits are given in the following pages. To meet the requests of our customers we have introduced a guard band on the series 3810 High Value Resistors. This is standard feature on all glass sealed resistors, type numbers 3810, 3811 and 3812 with resistance values above 100G (10^{11} ohms).



3810 series - High value resistors with values up to 100T (10^{14} ohms)

Specialist applications:

- Gas analysis
- Radiation monitoring
- Calibration

Specialist features:

- Permit measurement of current in the picoampere region
- Available to 1% tolerance
- Capacitance below 0.5pF
- Value of 100G & above are supplied with a guard band to eliminate the effects of leakage current

Application Note

Mechanical Details

The leakage path to be protected is the one existing on the external surface of the glass envelope. Although other leakage paths exist internally, the external one is subject to contamination and humidity effects. The silver band will be screen printed and fired on to the

external surface of the glass tube in which the resistor element is finally seated. The position of the band will be displaced from the centre of the resistor to a point located over one end cap and aligned with 1.5mm (as shown in Figure 1).

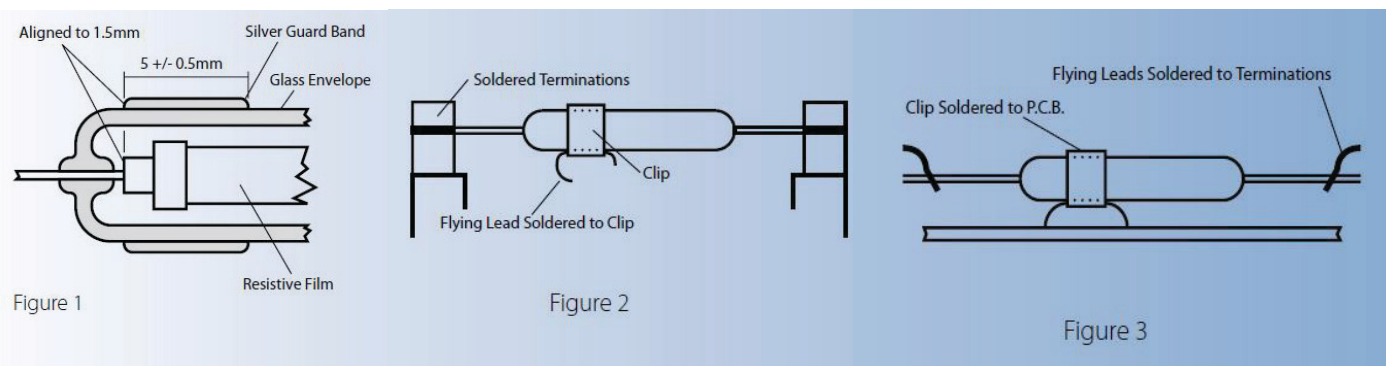

Resistor Mounting and Connection to the Guard Band

To obtain the best advantage from the guard band, and the improved performance that this can provide, connection should be made via the spring clip supplied with the resistor. Soldering a flying lead to the band is not recommended.

The clip may be used solely for connection, or it may be used as a mounting and connector (see Figures 2 and 3). Ideally, the resistors should be handled only by their terminations (warn your Goods Inward Inspection Department). If it is essential to handle the glass envelope, gloves should be worn.

Dynamic Response

High value resistors have long time constants, since even a small amount of self-capacitance can have a significant effect. The guard band can improve the dynamic performance because it forms an

electrostatic screen and will reduce the effective capacitance as well as the leakage resistance.

Measurement of High Value Resistors

Ability to make accurate high resistance measurements depends on several factors, but the essential ones are:

- i) Access to resistance standards of suitably high value and good stability
- ii) Availability of suitable low current detectors

Measurement to high accuracies (e.g. 10ppm uncertainty per $G\Omega$) require at least 100 volts DC applied to the resistors and preferably 500 volts. Measurement of the resistor with less than 100 volts applied presents difficulties because of the sensitivity of the detector will fall.

As resistance value and detector sensitivity increase, the need to use three terminal resistors becomes essential to obtain the best uncertainty. The existence of the third terminal to the guard band permits an assessment of the magnitude of the two external leakage paths. If these paths are shown to allow negligible leakage, then the guard band can be left disconnected, restoring the resistor to its original two-terminal form. However, the risk will remain that the two-terminal resistor will be prone to the effects of contamination or humidity.

Application Note

Guarding Circuits and Techniques

A resistor R_X with leakage R_L may be represented by the circuit shown in Figure 4, the guard band technique will introduce a third terminal, splitting R_L into two sections, R_{L1} and R_{L2} as shown in Figure 5.

In this configuration it is possible to measure the two leakage paths. In most circuits their effects can be nullified by suitably connecting the third terminal.

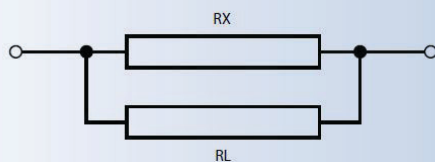

Figure 4

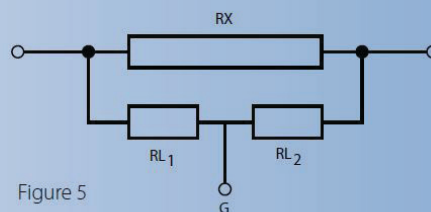

Figure 5

Inverter Amplifiers

The high value resistor with leakage may be placed in the input (R_{in}) or feedback (R_F) positions or both, as shown in Figure 6, but in either case the grounding of the guard band prevents leakage currents at the virtual earth, and the amplifier gain will be $-R_F/R_{in}$.

The input leakage current from V_{in} flows through the guard terminal G , to ground, and the output leakage currents flows through guard terminal G_2 to ground.

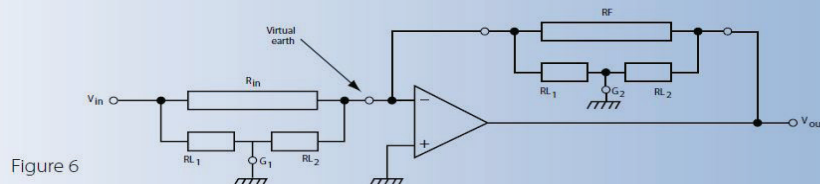

Figure 6

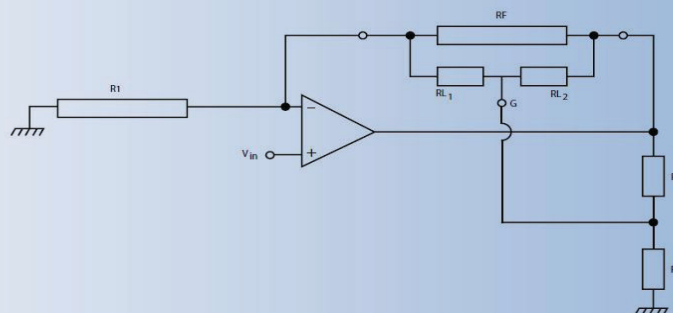

Figure 7

Follower with Gain

In the circuit shown in Figure 7

If $\frac{R_F}{R_1} = \frac{R_2}{R_3}$ the potential at the guard terminal G will be equal to V_{in}

Since there is now zero potential across R_{L1} , there can be no leakage current in this part of the total leakage path. The leakage current flowing in R_{L2} can be made a negligible quantity if R_2 and R_3 are low in value compared to R_{L2} . The gain of the amplifier become R_F/R_1 .

Application Note

Wheatstone Bridge

In Figure 8, by connecting the guard as shown, RL2 is across the detector, and does not affect the balance. RL1 shunts the ratio arm

R1 and if $R1 \ll RL1$ the error in the value of RX is small, $RX \approx RS(R1/R2)$ but in any case, if known, can be allowed for.

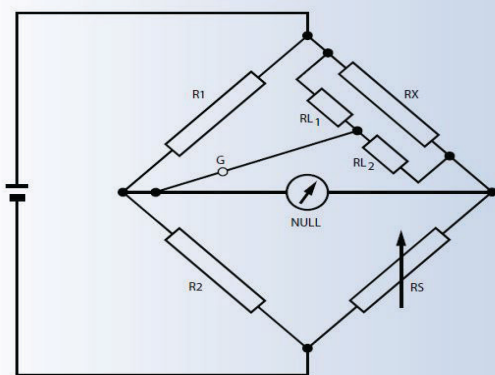

Figure 8

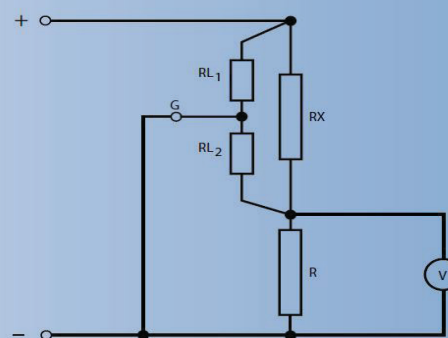

Figure 9

Voltage Divider

In the circuit shown in Figure 9, by making the guard connection the total leakage is again divided into RL1 and RL2, of which RL1 now appears across the supply and will not cause errors. RL2 appears across the low value resistor R and has much reduced ability to produce an error.

Example: with circuit values of $RX = 10^{12}$, $RL1 = 10^{14}$, $R = 10^8$
The nominal divider ratio is:

$$\frac{RX + R}{R} = \frac{10^{12} + 10^8}{10^8} = 10001$$

With the guard terminal unconnected the true ratio will be 9951, an error of -0.5%

Connection of the guard as shown makes the ratio 10001.01 and the error is now 0.0001%.

Note: Circuit diagrams shown for example only.



www.ttelectronics.com/resistors

TT Electronics, 4222 South Staples St., Corpus Christi, TX 78411, USA

TT Electronics, Welwyn Electronics Park, Bedlington, Northumberland, NE22 7AA, UK

General Note TT Electronics reserves the right to make changes in product specification without notice or liability
All information is subject to TT Electronics' own data and is considered accurate at time of going to print.
© TT Electronics plc