

# Amphenol<sup>®</sup> RF

Global RF Solutions

## FEATURES & BENEFITS

**True 75 Ohm impedance end to end**

**One piece spring alloy body/outer contact**

**Strip/Crimp requirements consistent with all major industry providers**

**Bayonet coupling provides a positive lock and allows for quick and easy connect/disconnects**

**Made by the Inventors of the BNC**

## APPLICATIONS

**Network Routing & Switching**

**Telco Central Office**

**DS3/DS4**

**Broadcast**

**Digital Video – HDTV**

**Custom Cable Assemblies**

**Instrumentation**

**Mil/Aero**

**Medical Equipment**

**Satellite Headends**



## True 75 $\Omega$ BNC Connectors

## True 75Ω BNC Connectors

Amphenol RF has worked hard to develop our high performance True 75 Ohm BNC product line and will continue to do so. Amphenol engineer Carl Concellman invented the BNC more the 60 years ago, and our engineers are still working to produce a variety of high quality RF solutions perfect for our customers' needs.

We offer a full line of 75 Ohm BNC connectors designed to meet the need for higher performance, impedance-matched cable interconnections. These connectors can be used in a variety of applications where True 75 Ohm performance is needed to ensure low signal distortion.

Our connectors are designed for the most popular 75 Ohm cables used in Broadcast, Telecommunications and various other RF applications, and feature crimp-crimp cable affixment compatible with Trompeter tooling, requiring no new training for quick and reliable installation.

Amphenol RF offers our True 75 Ohm BNC connectors in a variety of configurations: Straight, 45 degree and 90 degree plugs; as well as bulkhead, PCB and receptacle jacks.

If your applications requires a higher-density solution, contact us for information on our Mini-BNC product line.

## Specification

### Electrical

Characteristic Impedance	75 Ohm
Voltage Rating	500 Volts RMS
Insertion Loss	0.2dB Max., DC to 3.0 GHz
VSWR	< 1.10 (DC to 2.0 GHz) < 1.16 (DC to 3.0 GHz)
Return Loss	Better than 35 dB to 1 GHz; 30 dB to 2 GHz; 26 dB to 3 GHz
Contact Resistance	1.5 milliohms Maximum, center contact
Insulation Resistance	5000 MOhms minimum at 500 volts
Working Voltage	500 VAC peak
Frequency Range	DC - 4 GHz

### Mechanical

Mechanical Durability	500 cycles minimum
Center Contact Retention	6 lbs. minimum
Coupling Mechanism	100 lbs. minimum
Cable Pulloff Force	Dependent on cable size
Cable Bend and Twist	500 cycles minimum
Force to Engage/Disengage	1.5 lbs minimum, 5 lbs maximum/12 oz. minimum
Mating	2-stud bayonet lock

### Material

Inner Body	Phosphor bronze
Crimp Ferrule	Copper alloy
Contact Plating	Gold
Insulator	TFE, copolymer of styrene, glass-TFE (hermetically sealed)

### Environmental

Temperature Range	-40°C to + 85°C
Moisture Resistance	0% to 95%; MIL-STD-202 Method 106
Corrosion (Salt Spray)	MIL-STD-202 Method 101, Test Condition B
Flammability	UL 94-VO rated (center conductor insulator)
Vibration	MIL-STD-202 Method 201, Condition B
Solvent Resistance	MIL-STD-202 Method 215
Finish	Tarnish-resistant electroless nickel plating

### PLUG

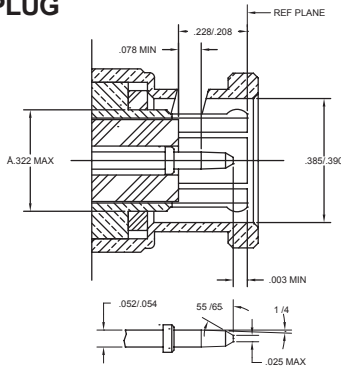

### JACK

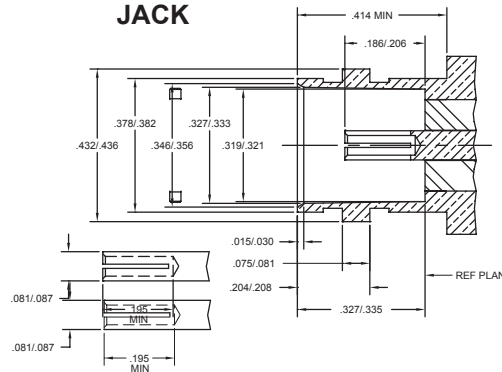

Rev. C