

## Antenna Application Note

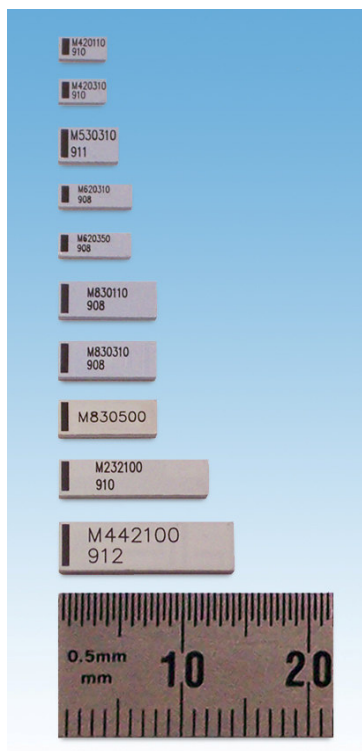

# ethertronics

shaping antenna technology™



## Savvi™ Embedded Ceramic Antennas

### Applications:

- Cellular Handsets**
- Wireless Headsets**
- PC/mini-PCI Cards – PDAs**
- Notebook PCs – Tablet PCs**
- Printers**
- Industrial Devices**
- Navigation Equipment**
- Media Players**
- M2M**

Bluetooth®  
 GPS  
 Bluetooth/GPS  
 Bluetooth/WiMAX/ZigBee®  
 WiMAX  
 WLAN  
 PCS Diversity/WiMAX



9605 Scranton Road, Suite 300  
 San Diego, CA 92121 USA  
 Ph: +(1) 858.550.3820  
 Fx: +(1) 858.550.3821  
 Email: [USASales@ethertronics.com](mailto:USASales@ethertronics.com)

**PROPRIETARY INFORMATION**  
 Release 4/30/2010  
 Product specifications subject to change without notice.

# Table of Contents

<b>1</b>	<b>PURPOSE</b>	<b>4</b>
<b>2</b>	<b>OVERVIEW</b>	<b>4</b>
<b>3</b>	<b>DESIGN GUIDELINES</b>	<b>7</b>
	3.1 Introduction	7
	3.2 Antenna Location	7
	3.3 Tuning Antenna Response on the PCB	8
	3.4 Performance Variation	9
	3.5 Tuning Guidelines (Savvi Antennas 3x1.5mm or smaller)	14
	3.6 Pad Layout Tips	20
<b>4</b>	<b>MATERIAL SPECIFICATIONS</b>	<b>21</b>
<b>5</b>	<b>PRODUCT TESTING</b>	<b>21</b>
<b>6</b>	<b>MANUFACTURING AND ASSEMBLY GUIDELINES</b>	<b>23</b>
<b>7</b>	<b>PRODUCT DEFINITIONS</b>	<b>35</b>
	7.1 Product Date Code	35
<b>8</b>	<b>GLOSSARY OF TERMS</b>	<b>35</b>
<b>9</b>	<b>APPENDIX 1</b> M830110 Savvi 8x3mm GPS Ceramic Antenna	<b>36</b>
<b>10</b>	<b>APPENDIX 2</b> M420110 Savvi 4x2mm GPS Ceramic Antenna	<b>38</b>
<b>11</b>	<b>APPENDIX 3</b> M310110 Savvi 3x1.5mm GPS Ceramic Antenna	<b>40</b>
<b>12</b>	<b>APPENDIX 4</b> M210110 Savvi 2x1.2mm GPS Ceramic Antenna	<b>42</b>
<b>13</b>	<b>APPENDIX 5</b> M830310 Savvi 8x3mm Bluetooth Ceramic Antenna	<b>44</b>
<b>14</b>	<b>APPENDIX 6</b> M620310 Savvi 6x2mm Bluetooth Ceramic Antenna	<b>46</b>
<b>15</b>	<b>APPENDIX 7</b> M620350 Savvi 6x2mm Bluetooth Ceramic Antenna	<b>48</b>
<b>16</b>	<b>APPENDIX 8</b> M530310 Savvi 5x3mm Bluetooth Ceramic Antenna	<b>50</b>
<b>17</b>	<b>APPENDIX 9</b> M420310 Savvi 4x2mm Bluetooth Ceramic Antenna	<b>52</b>
<b>18</b>	<b>APPENDIX 10</b> M420370 Savvi 4x2mm Bluetooth Ceramic Antenna	<b>54</b>
<b>19</b>	<b>APPENDIX 11</b> M310310 Savvi 3x1.5mm Bluetooth Ceramic Antenna	<b>56</b>
<b>20</b>	<b>APPENDIX 12</b> M210310 Savvi 2x1.2mm Bluetooth Ceramic Antenna	<b>58</b>
<b>21</b>	<b>APPENDIX 13</b> M830510 Savvi 8x3mm WLAN Ceramic Antenna	<b>60</b>
<b>22</b>	<b>APPENDIX 14</b> M310410 Savvi 3x1.5mm WiMAX Ceramic Antenna 3GHz	<b>62</b>
<b>23</b>	<b>APPENDIX 15</b> M210410 Savvi 2x1.2mm WiMAX Ceramic Antenna 3GHz	<b>64</b>
<b>24</b>	<b>APPENDIX 16</b> M442100 Savvi 14x4mm GPS/Bluetooth Ceramic Antenna	<b>66</b>
<b>25</b>	<b>APPENDIX 17</b> M232110 Savvi 12x3mm GPS/Bluetooth Ceramic Antenna	<b>68</b>
<b>26</b>	<b>APPENDIX 18</b> M032100 Savvi 10x3mm GPS/Bluetooth Ceramic Antenna	<b>71</b>

## Antenna Application Note

### RESTRICTED PROPRIETARY INFORMATION

The information disclosed herein is the exclusive property of Ethertronics Inc. and is not to be disclosed without the written consent of Ethertronics Inc. No part of this publication may be reproduced or transmitted in any form or by any means including electronic storage, reproduction, execution or transmission without the prior written consent of Ethertronics Inc. The recipient of this document by its retention and use agrees to respect the security status of the information contained herein.

Ethertronics may make changes to specifications and product descriptions at any time, without notice.

Ethertronics, Inc. assumes no responsibility or liability for any errors or inaccuracies that may appear in this document.

Copies of documents that are referenced in this document or other Ethertronics literature may be obtained by calling (858) 550-3820, email at [USASales@ethertronics.com](mailto:USASales@ethertronics.com) or the website [www.ethertronics.com](http://www.ethertronics.com).

Contact your local sales office or manufacturers' representative to obtain the latest specifications.

© 2010 Ethertronics. All rights reserved. The Ethertronics logo; shaping antenna technology, Isolated Magnetic Dipole, and Savvi are trademarks of Ethertronics. All other trademarks are the property of their respective owners. Product specifications subject to change without notice.

## Antenna Application Note

### 1. Purpose

This document provides information for incorporating Ethertronics' Savvi™ embedded ceramic antennas into wireless products. Specifications, design recommendations, board layout, packaging and manufacturing recommendations are included.

This document is divided into two parts: a main section and appendices. The main section addresses points and issues common to all products. The appendices provide product-specific information.

### 2. Overview

#### The Savvi Ceramic Product Line

The Savvi series of antennas, listed below, represents a new category of small form factor, internal antennas. Some Savvi antennas, developed for the same application, come in more than one form factor. These provide additional flexibility for designers, for instance, a much smaller size where slightly less performance is acceptable. Ethertronics antennas utilize proprietary and patented Isolated Magnetic Dipole (IMD) technology to meet the needs of device designers for higher functionality and performance in smaller/thinner designs.

<u>Part Number</u>	<u>Frequency</u>	<u>Application</u>	<u>Size</u>
M830110	1.575 GHz	GPS	8x3x1.33mm
M420110	1.575 GHz	GPS	4x2x1.08mm
M310110	1.575 GHz	GPS	3x1.5x1.08mm
M210110	1.575 GHz	GPS	2x1.2x1.08mm
M830310	2.4 - 2.5 GHz	Bluetooth	8x3x1.33mm
M620310	2.4 - 2.5 GHz	Bluetooth	6x2x1.08mm
M620350	2.4 - 2.5 GHz	Bluetooth	6x2x0.96mm
M530310	2.4 - 2.5 GHz	Bluetooth	5x3x1.08mm
M420310	2.4 - 2.5 GHz	Bluetooth	4x2x1.08mm
M420370	2.4 - 2.5 GHz	Bluetooth	4x2x0.96mm
M310310	2.4 - 2.5 GHz	Bluetooth/WiMAX 2G	3x1.5x1.08mm
M210310	2.4 - 2.5 GHz	Bluetooth/WiMAX 2G	2x1.2x1.08mm
M830510	2.4 - 2.5 GHz / 4.9 - 5.8 GHz	WLAN	8x3x1.33mm
M310410	3.4 - 3.6 GHz	WiMAX	3x1.5x1.08mm
M210410	3.4 - 3.6 GHz	WiMAX	2x1.2x1.08mm
M442100	1.575 GHz / 2.4 - 2.5 GHz	GPS/Bluetooth Combo	14x4x1.33mm
M232110	1.575 GHz / 2.4 - 2.5 GHz	GPS/Bluetooth Combo	12x3x1.33mm
M032100	1.575 GHz / 2.4 - 2.5 GHz	GPS/Bluetooth Combo	10x3x1.31mm

Additional antennas are under development, please see Ethertronics' Website, or ask your Ethertronics salesperson about additional products to meet your needs.

Product specifications subject to change without notice.

## Antenna Application Note



Figure 1

### IMD Technology Advantages

#### Real-World Performance and Implementation

Ceramic antennas may look alike on the outside, but the important difference is inside. Other antennas may contain simple PiFA or monopole designs that interact with their surroundings, complicating layout or changing performance with user position. Ethertronics' antennas utilize patented IMD technology to deliver a unique size and performance combination.

#### Stays in Tune

IMD technology provides superior RF field containment, so antennas resist de-tuning to provide a robust radio link regardless of the usage position. Other antennas may experience substantial frequency shifts, and lowered performance, when held by users or placed next to the head.

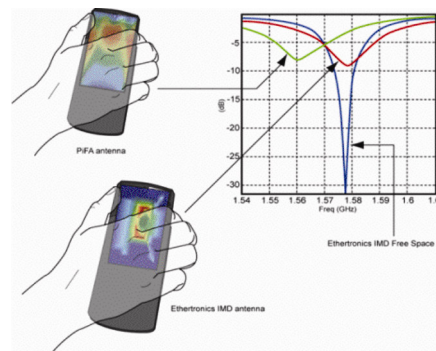

Figure 2



Figure 3

#### Standard Parts Work in Multiple Locations

High isolation also means a single part can be used for a variety of PCB sizes and in a variety of positions on the PCB. If re-tuning is required, it can be done by slightly changing the antenna ground clearance area on the PCB.

The GPS antenna should be located on the longest size of the PCB for best performance. Other Savvi antennas can be located along any edge.

#### Smallest Effective Size

A ceramic dielectric leads to a small physical size. However, unlike antennas using other technologies, IMD antennas require minimal ground clearance and keep-out areas for surrounding components. This can lead to a smaller “effective” size when all factors are taken into account. In addition to a small “x,y” footprint, Savvi antennas have very low component height to enable ultra-thin, end-user device designs.

Multi-band antennas can be packaged in a single device, which further saves PCB real estate while increasing functionality. And diversity antennas can be included to improve range, coverage and user experience.

#### High Performance

IMD technology enables antennas with high efficiency and high selectivity. **High efficiency** enables longer range and greater design margins in end products. **High selectivity** eliminates the cost and PCB space for additional filters.

IMD technology offers important real-world advantages over other approaches. Please see our white paper and Website [www.ethertronics.com](http://www.ethertronics.com) for a full explanation.

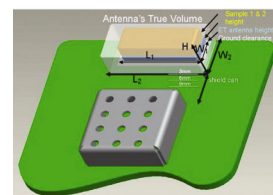

Figure 4

## Antenna Application Note

### Features, Advantages and Benefits Summary

Feature	Advantage	Benefits
High performance	High efficiency	Meet and exceed design performance specs. Lower design risks. Enhance end-user satisfaction. Potential for additional device sales.
	High isolation	Less interaction with surrounding components. Smallest effective antenna size when component keep out areas included. Resists de-tuning due to orientation on circuit board. Lowers design risk and time to market. One antenna part number can serve multiple designs. Simplifies design and ordering.
	High selectivity	Eliminates need for additional band-pass filters and other circuitry. Saves cost and space.
Compact Size	Enables design of smallest, thinnest product designs.	Saves board space. Fits into areas other antennas won't. Increases functionality and sales potential.
Superior RF Field Containment	Virtually eliminates detuning due to device handling during use.	Better performance. Higher end-user satisfaction. Potential for higher sales.

### IMD Technology: How it works

IMD technology uses confinement of the electrical field to create the antenna's mode. The strongly confined antenna mode reduces its coupling to the surrounding environment. The diagram to the right shows the electrical field created on the PCB ground plane for an Ethertronics IMD antenna and a PiFA (Planar Inverted F Antenna). Red areas indicate the highest current while blue areas signify the lowest. As demonstrated, currents from the IMD design are highly localized, while high currents are observed all the way over to the ground plane edge on the PiFA.

Ethertronics' IMD antennas are ideally suited for wireless data devices, where performance, size and system costs are critical. The surface mount design and compact size are suited for high volume applications. Standard antenna profiles are available or can be configured to suit individual OEM requirements.

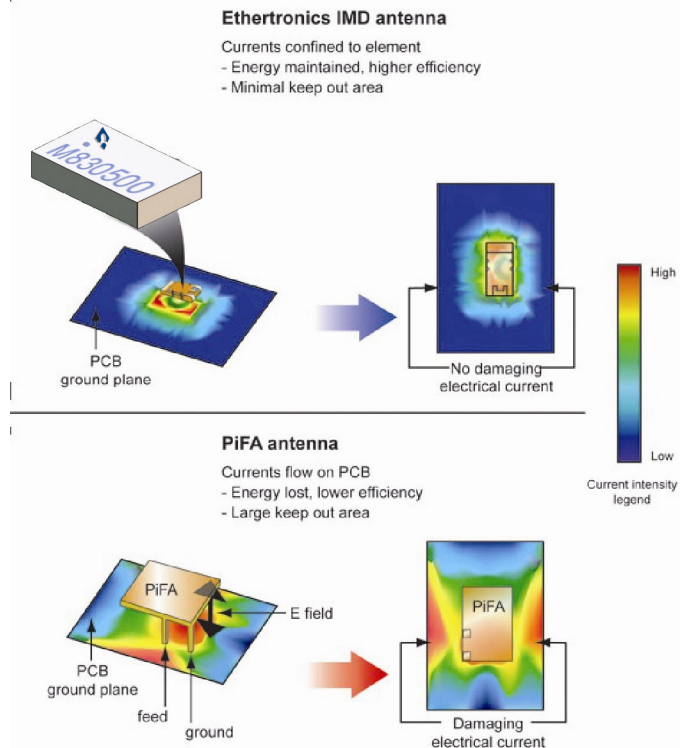

Figure 5

## Antenna Application Note

### 3. Design Guidelines

#### 3.1 Introduction

The Savvi™ line of Ethertronics' ceramic embedded antennas can be designed into many wireless product types. The following sections explain Ethertronics' recommended layouts to help the designer integrate the antenna into a product with optimum performance.

#### 3.2 Antenna Location

In order to create an optimized layout for the antenna, one must first understand the Savvi ceramic antenna's unique characteristics, which enable it to offer superior performance. The antenna's performance behavior is controlled by many variables in the surrounding environment. Ethertronics' technical team has determined that several rules are important to take into account when designing a product using this antenna, see Figure 6 below:

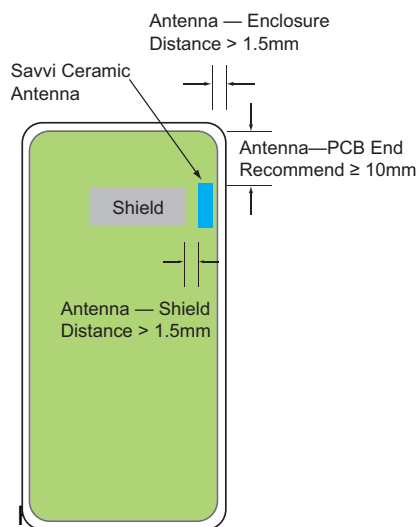

Figure 6

1. Long side of antenna must be along the edge of the ground plane.
2. Ground plane is removed from all layers below the antenna.
3. The distance from the antenna to the enclosure or plastic cover, referred to as **“Antenna – Enclosure” distance**, should be greater than 1.5mm.
4. The distance from the antenna to relatively large perturbations, such as a nearby shield or large components, is referred to as **“Antenna – Shield” distance**. This distance is dependent on the height of surrounding components, but should not be less than 1.5mm. See Figure 2.
5. The minimum distance from the end of the antenna to either end of the PCB is referred to as the **“Antenna--PCB End” distance**. We recommend a distance equal to or greater than 10mm, with better performance from larger distances. Because of IMD's high performance, some designs may allow for smaller distances.

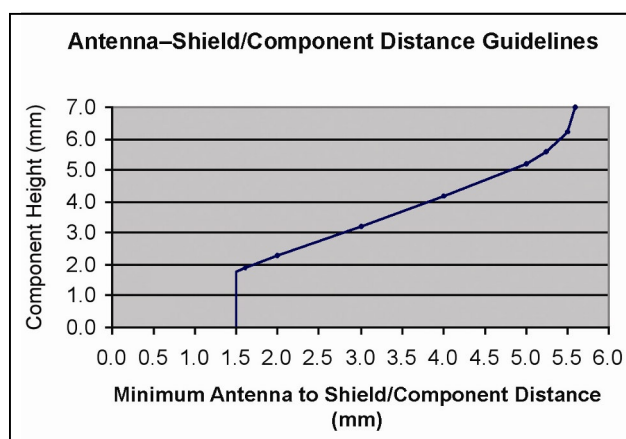

Figure 7

Figure 7 at left shows the Minimum Antenna – Shield and/or Component Distance

## Antenna Application Note

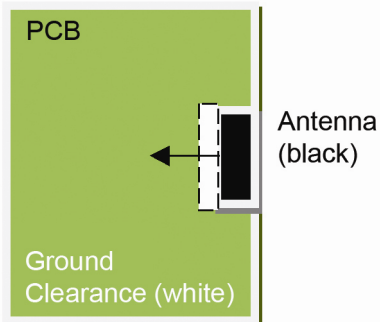

Figure 8

### 3.3 Tuning Antenna Response on the PCB

Recommendations for ground clearance on an antenna-by-antenna basis are provided in the appendix. In some cases, it may be necessary to tune the response of the antenna once it is placed on the PCB. This can be done by changing the ground clearance around the antenna. The amount of clearance along the width of the antenna is the most sensitive at effecting changes. Increasing ground clearance in the direction of the arrow (see Figure 8 to the left), lowers the frequency at which return loss peaks. (Note M620350, M420370 and M830510 do not follow the above guidelines). Matching can also be used for additional tuning alternatives.

Figure 9 below show changes in response for the 14x4mm GPS/Bluetooth ceramic antenna. The size differences noted on the charts, such as 14.2mmx6mm, are the length and width of the ground clearance under and around the antenna. The diagram on the left shows changes in response to variations along the width of the antenna (these also correspond to the drawing above). The second chart shows changes in antenna response due to increases in ground clearance along the length of the antenna.

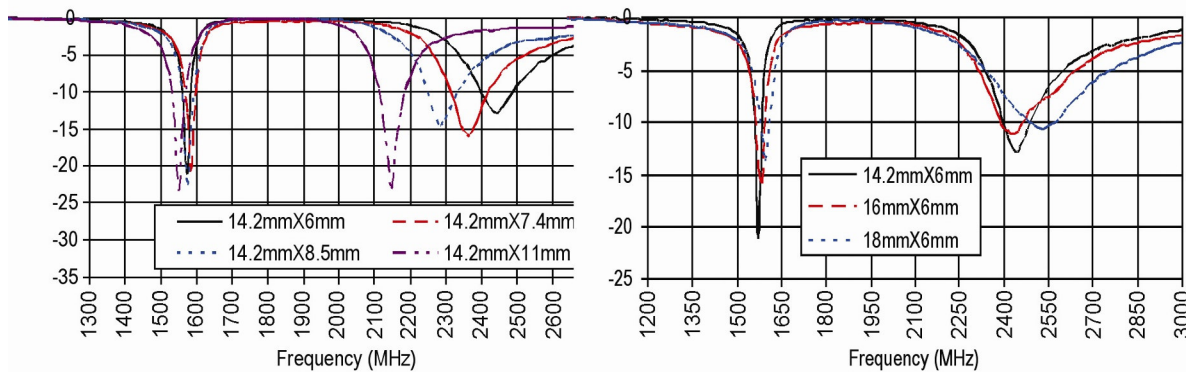

Figure 9

It is clear from the diagrams that the Bluetooth® frequency ranges were impacted the most. It is also clear that changes to the ground clearance along the width of the antenna had the most impact, although changes to both sides had some impact.

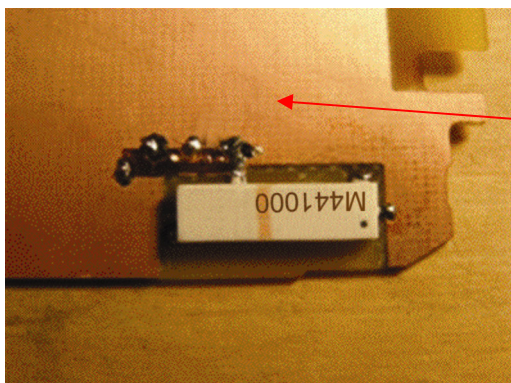

Figure 10

In the case of prototypes, it is possible to quickly experiment with changes by adding copper tape or strips, or removing copper around the antenna. See Figure 10 to the left for an example.

Tuning was done by reducing the ground plane on the Bluetooth side.

## Antenna Application Note

### 3.4 Performance Variation



Figure 11

The performance data contained in the appendices are based on recommended ground clearance, pad layouts and antenna placement. Each antenna was positioned at the edge of an 80mmx40mm PCB, at the middle of the longest side. The antenna feed was routed through a via hole to the underside of the board, and connected to a 50 ohm micro strip. This micro strip was routed across the short side of the board to a 50 ohm connector. A picture of the test board for a Bluetooth® antenna is shown in Figure 11 to the left. The dotted line indicates the transmission line on the underside of the PCB.

This section of the application note is intended to provide information on how performance varies outside the conditions used to measure the data in the appendices. It should be noted that there are variations that exist from one type of antenna to another, such as Bluetooth versus GPS. And combination antennas present their own special circumstances. Nevertheless, knowledge of how antenna placement, board size, and other factors impact performance can be helpful in making implementation decisions.

#### Variations in GPS efficiency based on proximity to PCB edge

Tests were run on the 8x3mm GPS antenna to document how efficiency varied from the distance the antenna was placed from the right and left PCB edges, see Figure 12 below for results. Substantial efficiency increases were obtained at distances above 10mm from the short end of the board, with further increases obtained at increasing distances from the end. There was less efficiency drop off from the left end. In general, Ethertronics recommends that antennas be positioned 10mm or more from the PCB end. Because of the high efficiency of IMD antennas, some designs may be able to meet their performance criteria at closer distances.

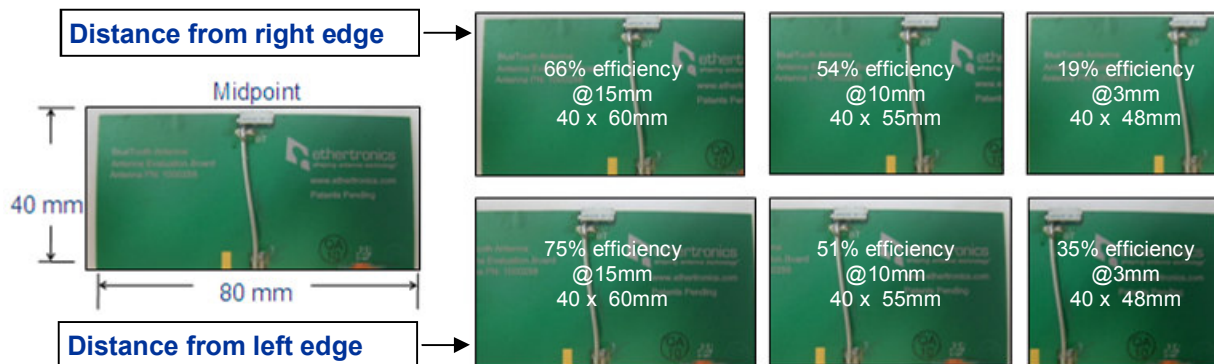
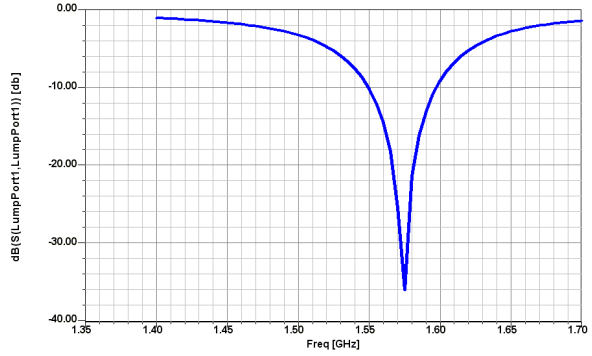
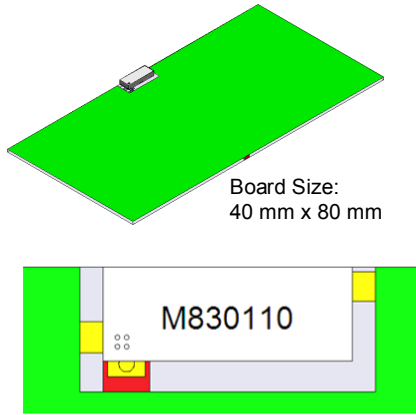

Figure 12

### Increasing efficiency through board layout changes

Additional testing was done to increase efficiency and performance when the 8x3mm GPS antenna is placed only 3mm from the board edge. By making changes to the board layout, efficiencies greater than 60% with 31 to 36 MHz bandwidth can be achieved.

#### Demo Board



- Peak efficiency: 80%
- Bandwidth (-7 dB): 83MHz

Figure 13

#### Location 1

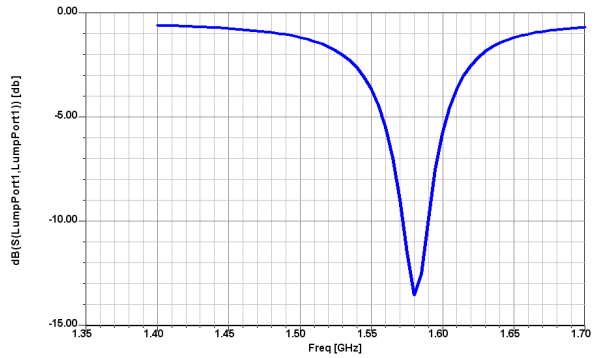
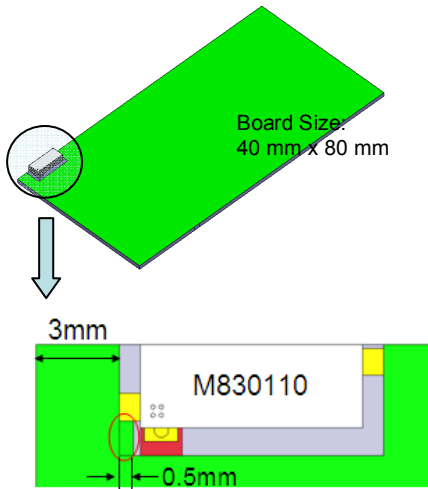

- Peak efficiency: 67%
- Bandwidth (-7 dB): 36MHz

Figure 14

Recommended board layout change in red circle: needs to fill the gap by 0.5mm to optimize the performance.

**Location 2**

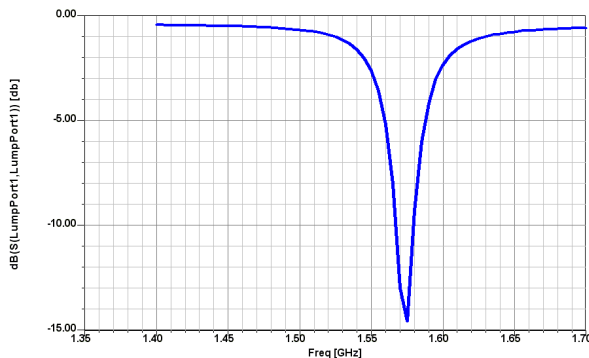
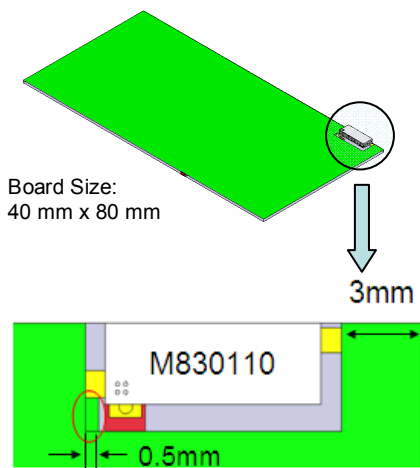

- Peak efficiency: 48%
- Bandwidth (-7 dB): 24MHz

Figure 15

Recommended board layout change in red circle: needs to fill the gap by 0.5mm to optimize the performance

In summary, with minimal board layout changes, the 8x3mm GPS antenna can be optimized on the corner location, 3mm away from the PCB edge. Locating the antenna closer to the edge of the PCB will reduce the bandwidth. Location 1, Figure 14 on previous page, shows good efficiency and more bandwidth compared to Location 2, Figure 15 above. However, Location 2 can be avoided by placing the antenna on the bottom side of the PCB. This placement is the same as Location 1.

In general, Ethertronics recommends that antennas be positioned on the long side of the PCB if possible. To achieve the best performance, antennas should be placed in Location 1 with 10mm or more from the PCB edge.

## Antenna Application Note

### Performance variations based on antenna orientation

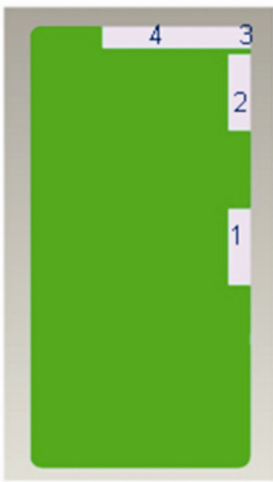

Tests were run at different positions on a 40x80mm PCB using the 14x4mm GPS/Bluetooth dual band antenna (see placement in Figure 16 to the left and results in Figures 17 and 18 below). Test findings indicate that GPS performance was better along the long side of the board. For this reason, Ethertronics recommends that GPS-only antennas be placed along the long PCB side—a better position for the GPS/Bluetooth antenna as well. The Bluetooth® antenna in the combo unit had better return loss and efficiency on the short edge. If it is necessary to place the combination unit on the short edge, the shift in frequency response can be adjusted by changing the ground clearance, per section 3.2 of this application note.

Figure 16

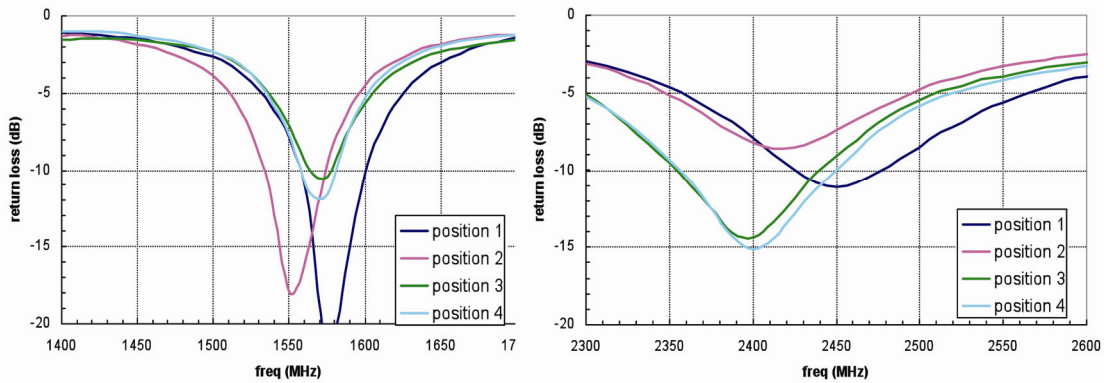

Figure 17

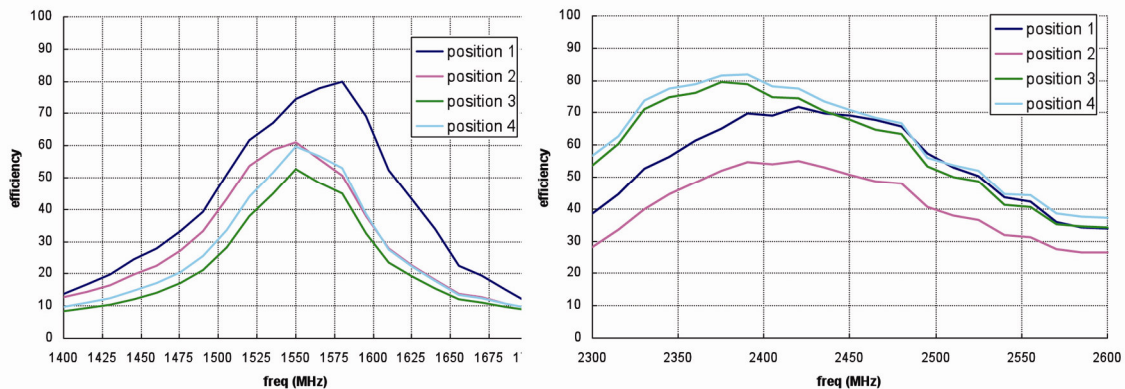

Figure 18

## Antenna Application Note

### Performance variations based on PCB board size

Impacts of board size were investigated using four different antenna placements of the 8x3mm GPS antenna. Antennas were placed 10mm from the top left and top right, and 10mm from upper right and upper left sides (see Figure 19 below for placement examples and Figure 20 below for results). The size of the PCB was varied along the width and length of each configuration. Note, the GPS antenna was not tested on the “short” side of the board. Current GPS products should always be placed on the long side of the PCB.

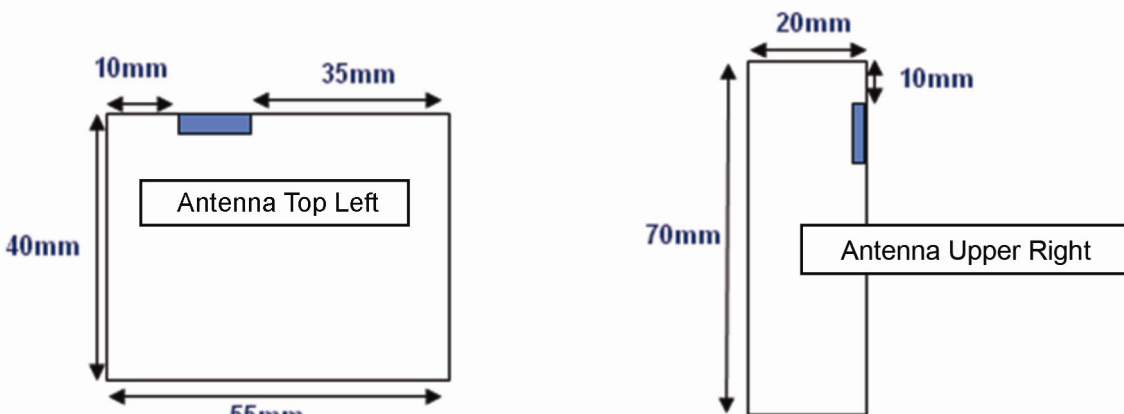

Figure 19

### Conclusions were:

- Efficiency increases with overall PCB area
- Efficiency is better on rectangular PCBs than on square
- Expanding the PCB along either the width or length increases efficiency
- Antenna placement on the upper right side increased efficiency 5-10% versus placement on the upper left side
- Antenna placement near the top left increased efficiency 5-10% versus placement on the top right

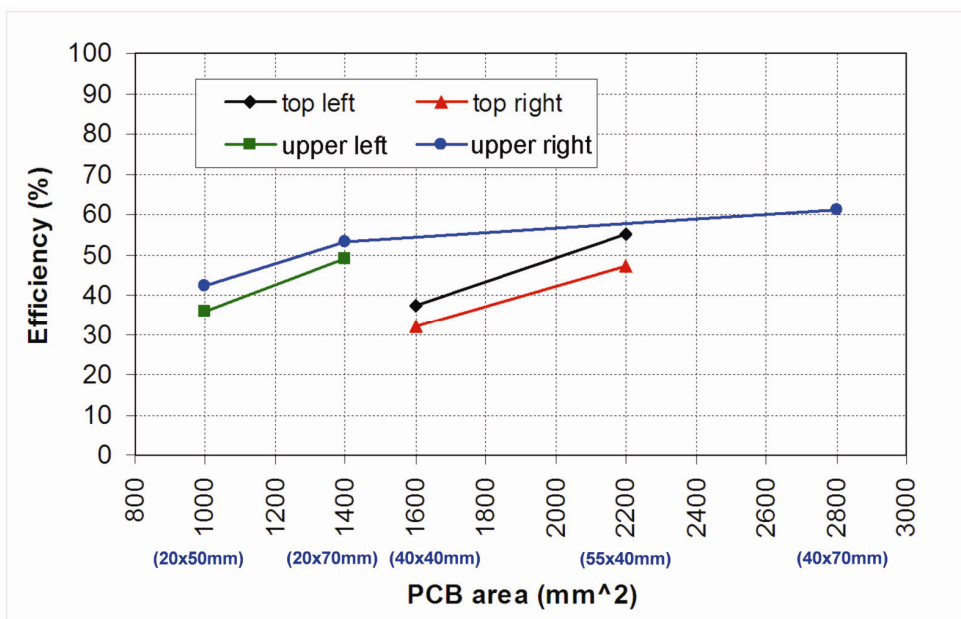

Figure 20

## Antenna Application Note

### Antenna performance unaffected by plastic housings

1.2 mm ABS plastic was positioned at various distances from Ethertronics GPS and Bluetooth® antennas to simulate the impact that plastic covers might have on antenna performance. The result was negligible detuning over spacing of 1.5mm or greater (see Figure 21 below).

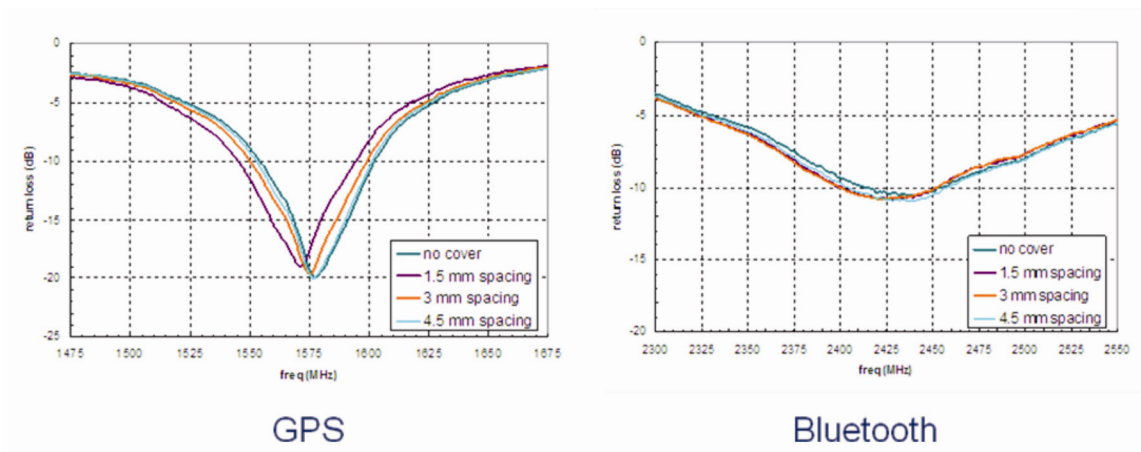

Figure 21

### 3.5 Tuning Guidelines (Savvi Antennas 3x1.5mm or smaller)

#### EV-Board Structures

The following are tuning guidelines for Savvi Ceramic Antennas 3x1.5mm and smaller. These antennas require the use of a matching circuit for tuning.

#### GPS EV-Board

The Evaluation Boards for GPS 3x1.5mm and 2x1.2mm have each antenna placed in the three different locations for evaluation purposes. The optimal location is the long center side. The clearance size is 10x4 mm (see Figure 22 below).

Part Numbers:

- M310110 (3x1.5mm)
- M210110 (2x1.2mm)

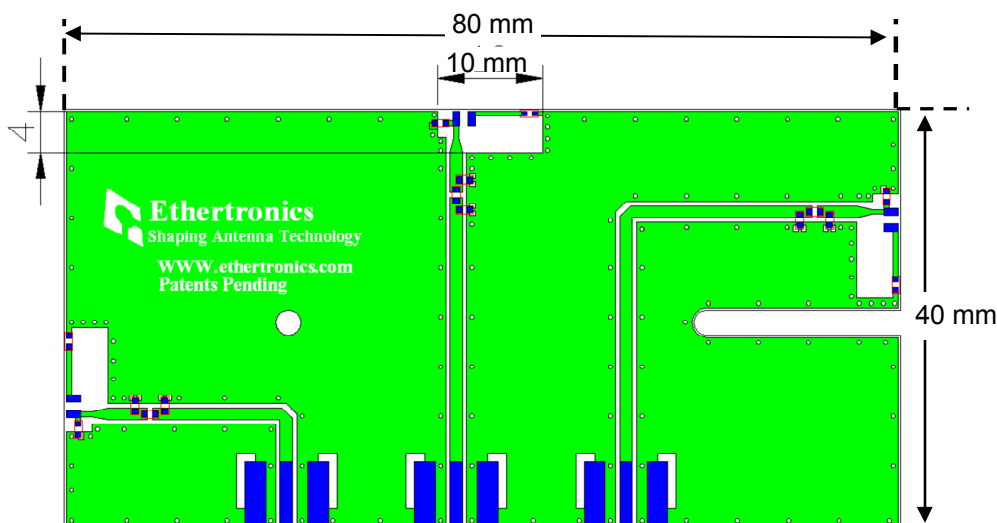

Figure 22

## Antenna Application Note

### BT, WiMAX EV-Board

The Evaluation Boards for Bluetooth and WiMAX 3x1.5mm and 2x1.2mm have each antenna placed in the three different locations for evaluation purposes. The optimal location is the long center side. The clearance size is 7x4mm (see Figure 23 below).

#### BT Part Numbers:

- M310310 (3x1.5mm)
- M210310 (2x1.2mm)

#### WiMAX Part Numbers:

- M310410 (3x1.5mm)
- M210410 (2x1.2mm)

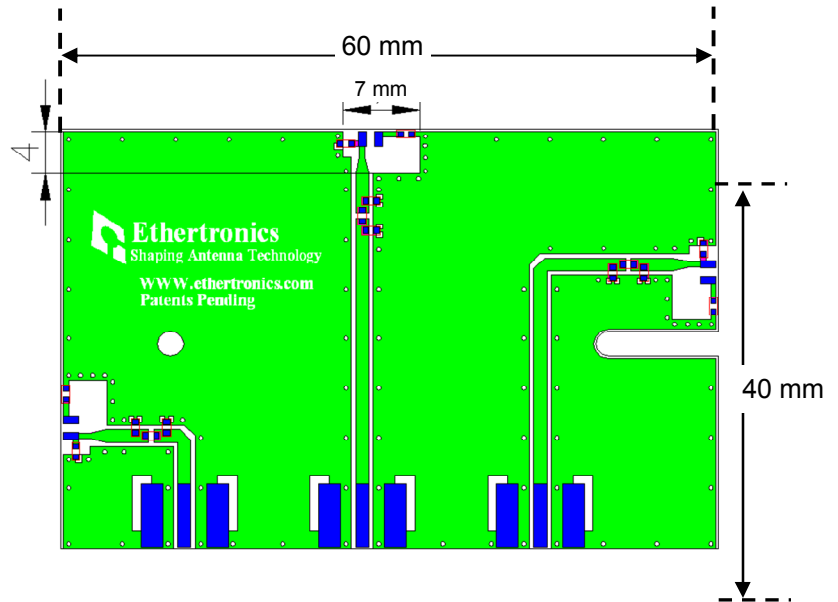

Figure 23

## Antenna Application Note

### Tuning the frequency by changing the major tuning component

- The frequency can be tuned across a broad range by changing the Capacitor value, see Figure 24 to the right.

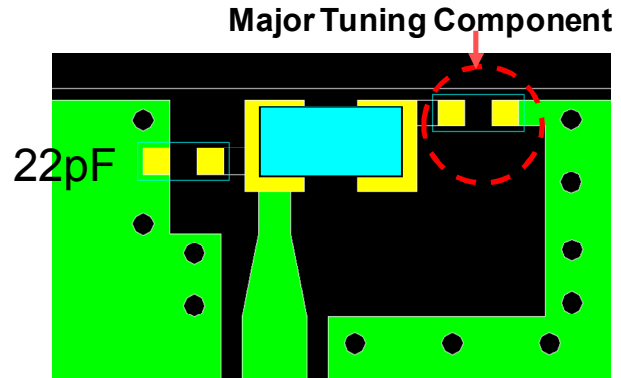

Figure 24

See Figure 25 to the right to see the results of changing the Capacitor value on Return Loss

- When the Capacitor value is decreased, the frequency shifts higher

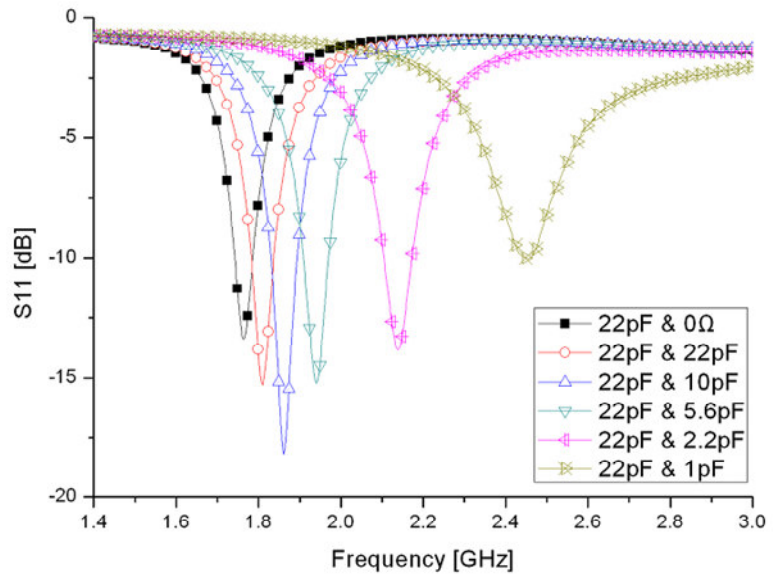

Figure 25

See Figure 26 to the right to see the corresponding efficiency graphs

- Varying the Capacitor value does not severely degrade efficiency

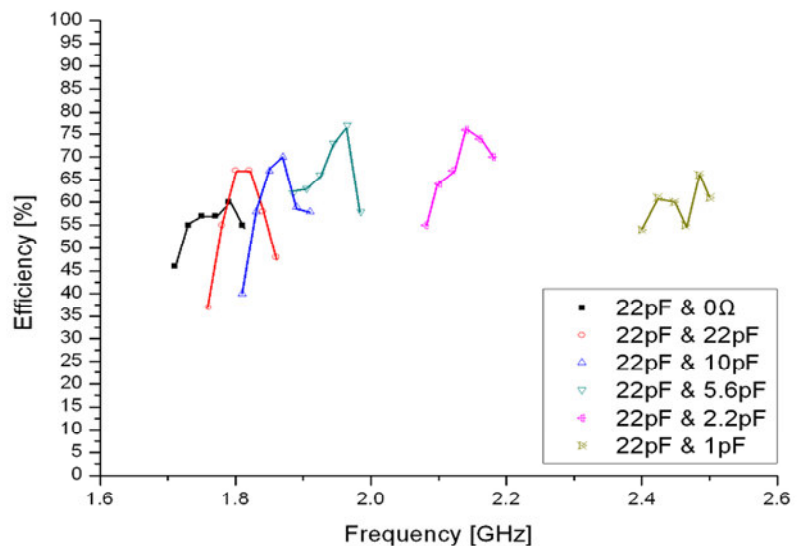

Figure 26

## Antenna Application Note

A low value Inductor can be used to shift the frequency lower; instead of a Capacitor. However, using too high of an inductance value will degrade the efficiency.

See Figure 27 to the right and Figure 28 below to see the results of changing the Inductor value on Return Loss and the corresponding Efficiency.

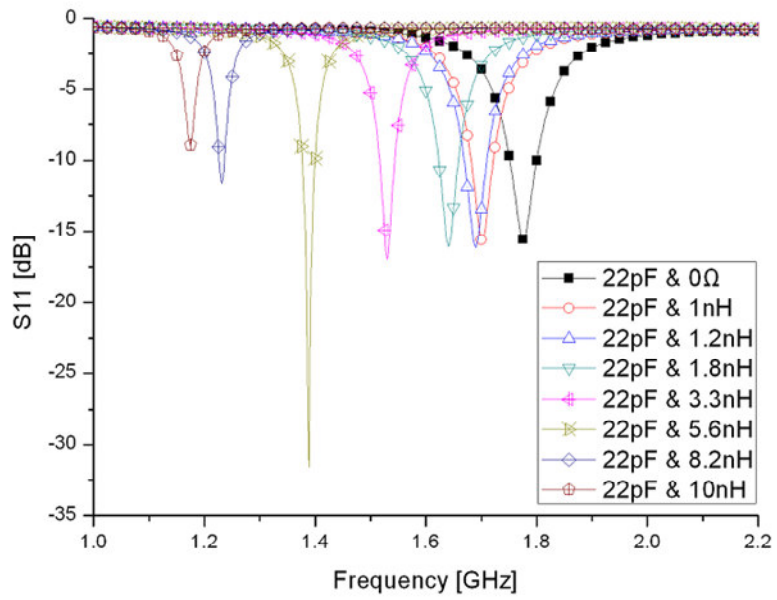

Figure 27

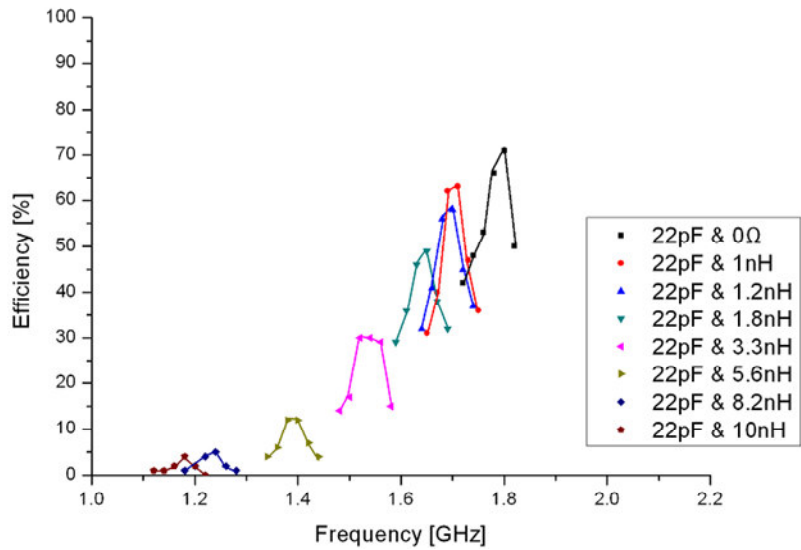

Figure 28

## Antenna Application Note

### Tuning the frequency by changing the minor tuning component

- VSWR and the operating bandwidth can be optimized by changing the Capacitor value.

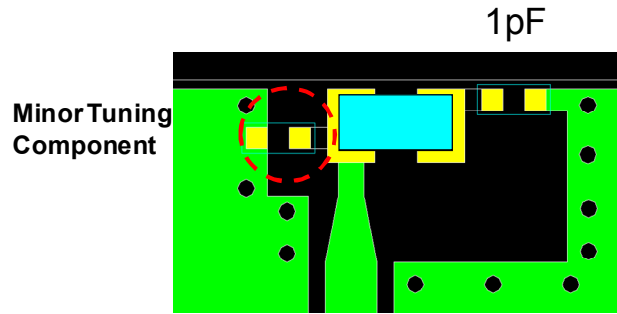

Figure 29

See Figure 30 to the right and Figure 31 below to see the results of changing the Capacitor value on Return Loss and the corresponding Efficiency

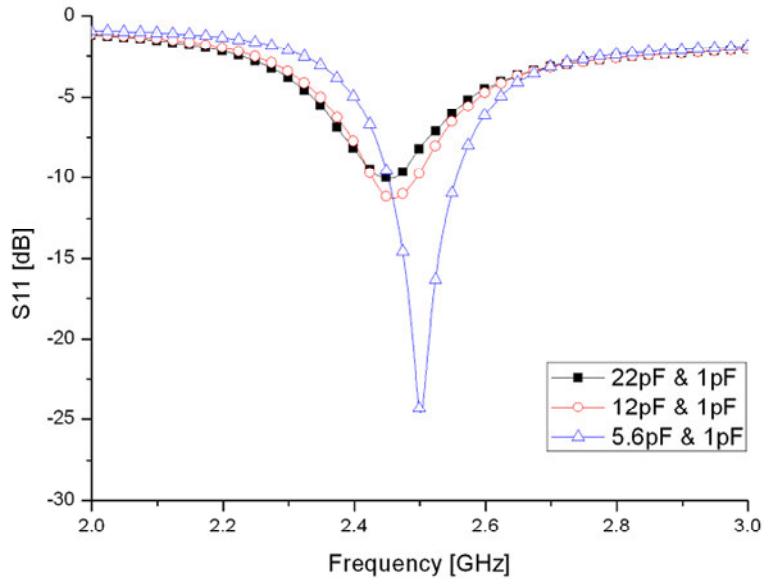

Figure 30

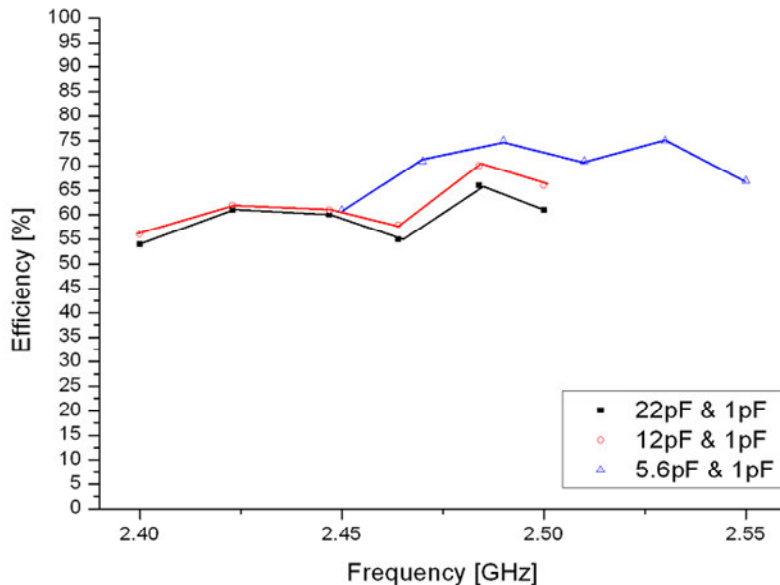

Figure 31

## Antenna Application Note

### Performance variations based on board size

The board size is reduced as shown in Figure 32 at right to demonstrate the performance variations. See Figures 33 and Figure 34 below to see the performance variations with respect to Return Loss and Efficiency.



Figure 32

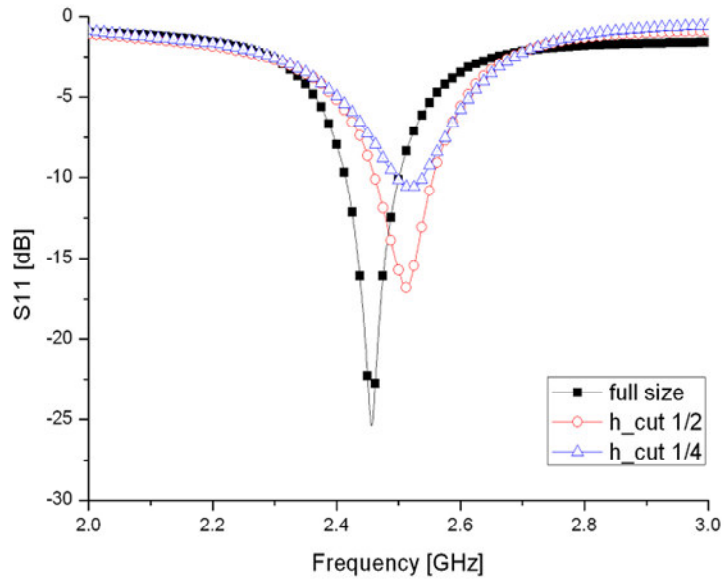

Figure 33

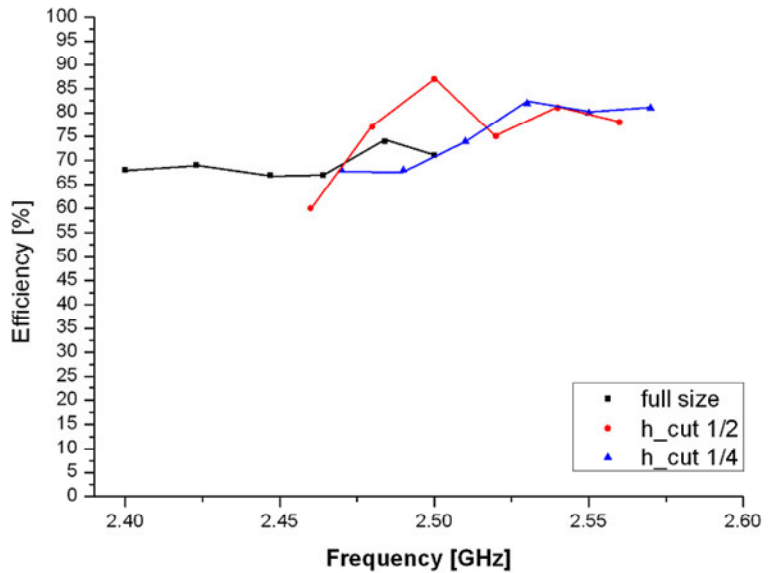
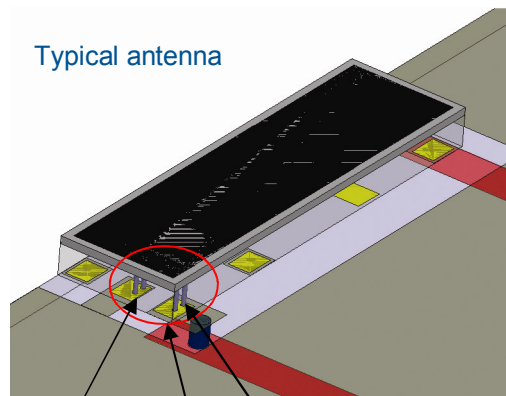

Figure 34

## Antenna Application Note

### 3.6 Pad Layout Tips

**Important, layout guidelines for correct operation of Ethertronics Savvi Ceramic Antennas. Please read guidelines below before laying out the antenna in your device. Figure 35 shows the typical antenna layout. Figure 36 shows Ethertronics' antenna layout.**



Shorting pin    Feed pin

Antenna tuning loop:

- Change loop size in Smith chart to control bandwidth.
- Give more separation between the feed and the shorting pin to increase loop size in Smith chart.

Figure 35

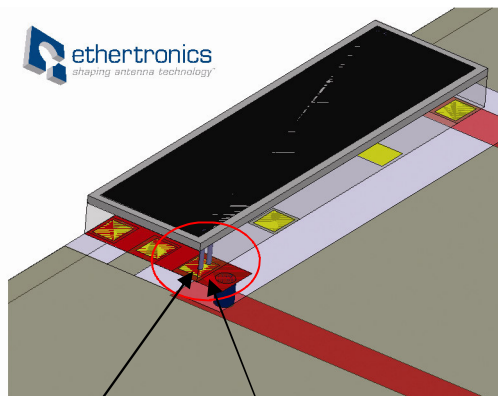

Shorting pin and feed pin are shared in Ethertronics ceramic antennas

- The antenna tuning loop is formed in the PCB board.
- The feed pin and shorting pin are combined because it requires very close proximity to achieve more bandwidth.
- It can relieve constraint on bottom pad layout (min. 0.65mm distance between pads).
- It shifts frequency down.

Figure 36

## Antenna Application Note

### 4. Material Specifications

Item	Material
Metal Element	Silver ink
Composite Structure	Ceramic
Contact Finish	Ni-Au

### 5. Product Testing

Ethertronics' antennas comply with RoHS directives. Ethertronics' antennas undergo product qualification testing as part of the product development process. The following are the core tests used to qualify the Savvi™ ceramic antennas.

Table 1 Product Qualification Tests

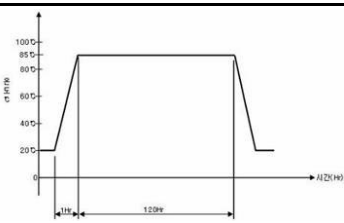
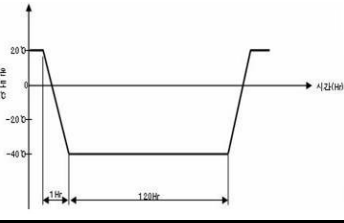
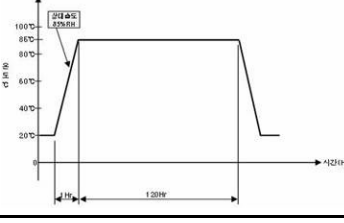
NO	Test Type	Items	Test condition	Test method
1	Environment test	High Temp.	85°C±3°C 120hr ±2hr	 <p>Step 1: Test VSWR by jig. Step 2: Put it in the chamber. Step 3: Test it like this picture which explains temp. cycle. Step 4: Test VSWR after 1hr in normal Temp. &amp; normal Humidity</p>
2		Low Temp.	-40°C±3°C 120hr ±2hr	 <p>Step 1: Test VSWR by jig. Step 2: Put it in the chamber. Step 3: Test it like this picture which explains temp. cycle. Step 4: Test VSWR after 1hr in normal Temp. &amp; normal Humidity</p>
3		High Temp. & High Humidity	85°C±3°C RH=85% 120hr ±2hr	 <p>Step 1: Test VSWR by jig. Step 2: Put it in the chamber. Step 3: Test it like this picture which explains temp. cycle. Step 4: Test VSWR after 1hr in normal Temp. &amp; normal Humidity</p>
4		Salt Spray	Nacl 5%, 35°C, 72hr	<p>Step 1: Test VSWR by jig. Step 2: Put it in the chamber. Step 3: Start test. Step 4: Wash the samples. Step 5: Test VSWR after 1hr in normal Temp. &amp; normal Humidity</p>
5		PCT	120°C, RH=100%, 96hr	<p>Step 1: Test VSWR by jig. Step 2: Put it in the chamber. Step 3: Test it like this picture which explains temp. circle. Step 4: Test VSWR after 1hr in normal Temp. &amp; normal Humidity</p>

Product specifications subject to change without notice.

## Antenna Application Note

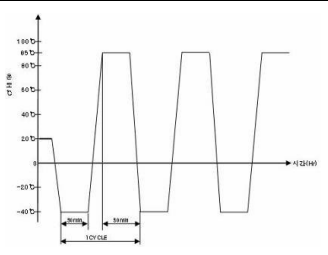
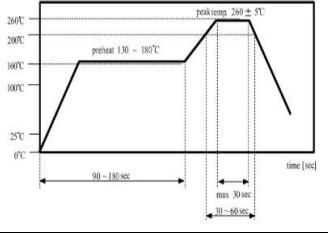
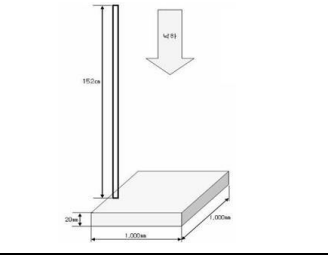
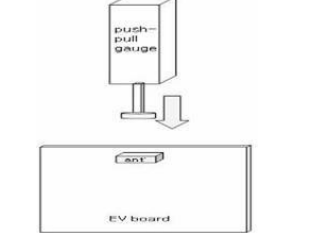
NO	Test Type	Items	Test condition	Test method
6	Environment test	Thermal shock	-40°C±3°C/30min, 85°C±3°C/30min, 32cycle	 <p>Step 1: Test VSWR by jig. Step 2: Put it in the chamber. Step 3: Test it like this picture which explains temp. cycle. Step 4: Test VSWR after 1hr in normal Temp. &amp; normal Humidity</p>
7	Reflow test	Reflow test	Pre Heating 200°C±5°C 30~60sec Peak Heating 260°C±5°C 30sec Max	 <p>Step 1: Put it in REFLOW Step 2: Test it like this picture which explains temp. Cycle by EV board</p>
8	Mechanical Test	Vibration	-Frequency: 10~500hz -Acceleration: 10*9.8m/s <sup>2</sup> (G) -Sweep time 15min -X.Y.Z each 5times	<p>Step 1: Solder antenna on EV board. Step 2: Assemble EV board (+antenna) on set. Step 3: Test it.</p>
9		Drop	-From 100cm height, drop the sample to the bottom 18 times per one test by drop jig. (each 3 times on 6 surfaces) -Jig: using the plastic jig (120±20g) -Material of Bottom: Iron Plate	 <p>Step 1: Solder antenna on EV board Step 2: Assemble EV board (+antenna) on set. Step 3: Test it like this picture which explains how to do it.</p>
10		Adhesive Strength	-Measure the intensity by pulling the sample on PCB fixed by SMT. -Equipment: PUSH-PULL GAUGE	 <p>Step 1: Solder antenna on EV board Step 2: Assemble EV board (+antenna) on set. Step 3: Test it like this picture which explains how to do it.</p>

## Antenna Application Note

### 6. Manufacturing and Assembly Guidelines

Ethertronics' ceramic antennas are designed for high volume board assembly. Because different product designs use different numbers and types of devices, solder paste, and circuit boards, no single manufacturing process is best for all PCBs. The following recommendations have been determined by Ethertronics, based on successful manufacturing processes.

These ceramic antennas are designed for automated pick and place surface mounting. However, as with any SMT device, Ethertronics antennas can be damaged by the use of excessive force during the handling or mounting operation.

#### Component Handling Recommendations

The following are some recommendations for component handling and automated mounting:

- Pick and place machines should use mounting heads that have a compliant nozzle or force control.
- For manual mounting and handling, vacuum pens should be used to pick-up, transfer and mount the antennas.

Ethertronics' antennas are not moisture sensitive and the ceramic antennas meet the requirements for a Level 1 classification of J-STD-020A (moisture/reflow sensitivity classification for non-hermetic solid state surface mount devices from the Institute for Interconnecting and Packaging Electronic Circuits). Nevertheless, as a precaution to maintain the highest level of solderability, Ethertronics antennas are dry-packed.

(NOTE: Normal oxidation may result in a slight discoloration of the gold nickel surface. This has no effect on the performance of the antenna.)

#### Paste Stencil Recommendation

Ethertronics recommends application of paste stencil to a thickness of 0.1mm, applied to within 0.05 mm of the solder mask surrounding each exposed metal pad on the PCB. PCB layouts for each antenna are provided below.

#### Soldering Recommendations

The recommended method for soldering the antenna to the board is forced convection reflow soldering. The following suggestions provide information on how to optimize the reflow process for the ceramic antenna:

- Adjust the reflow duration to create good solder joints without raising the antenna temperature beyond the allowed maximum of 260° C.

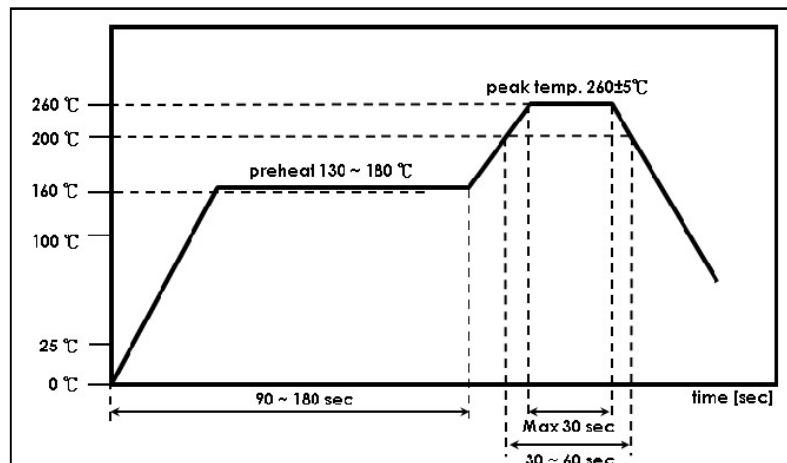

Product specifications subject to change without notice.

## Antenna Application Note

### Glue Recommendations

Ethertronics recommends using glue as an under fill for increased adhesion strength. Please contact Ethertronics for more information.

Recommended glue: ThreeBond 2210B or similar.

### Additional Manufacturing Recommendations

Care should be taken during certain customer-specific manufacturing processes including PCB separation and Ultrasonic Welding to ensure these processes don't create damage to the components.

### Cleaning Recommendations

After the soldering process, a simple wash with de-ionized water sufficiently removes most residues from the PCB. Most board assembly manufacturers use either water-soluble fluxes with water wash, or "no clean" fluxes that do not require cleaning after reflow.

**Acceptable cleaning solvents** are CFC alternatives, Isopropyl Alcohol (IPA), and water. If the application uses other types of solvents, please consult with Ethertronics.

**Cleaning processes that should be avoided** are ultrasonic cleaning and any abrasive techniques, such as scrubbing with a cotton swab.

### Rework & Removal Recommendations

There may be a need to rework or remove the antenna from the PCB. Although Ethertronics' antennas are designed for ease-of-use, use care when separating them from the PCBs. Careless heating or removal of the antenna can cause thermal, mechanical or lead damage. These degradations may render the antenna useless, impeding any failure analysis and preventing the reuse of the device. Therefore it is recommended to observe the following precautions:

- The component can be reworked and soldered by hand using a soldering iron. However care should be used so the temperature does not exceed 260°. The soldering iron should not touch the composite material while soldering the leads of the antenna.
- The component can be reworked and soldered using a hot air rework station. However, care should be taken to ensure that the temperature does not exceed 260° C.
- Once the solder on the PCB is sufficiently heated, use a vacuum pen to lift the antenna straight up off the PCB. Avoid twisting or rotating the device while removing it.

## Antenna Application Note

### Tape & Reel Specifications

Tape and Reel specifications vary with the size of the antenna. Below is a table indicating the standard quantity per reel and box for each given antenna size.

Antenna Size	Qty per Reel	Qty per 1 Box
2x1.2 mm	10,000	50,000
3x1.5 mm	10,000	50,000
4x2 mm	10,000	50,000
5x3 mm	4,500	22,500
6x2 mm	10,000	50,000
8x3 mm	4,500	22,500
10x3 mm	5,000	20,000
12x3 mm	4,500	22,500
14x4 mm	4,500	22,500

Listed on the following pages are the tape and reel specifications for the various Ethertronics ceramic antennas.

# Antenna Application Note

## Tape & Reel Specifications 14mm x 4mm

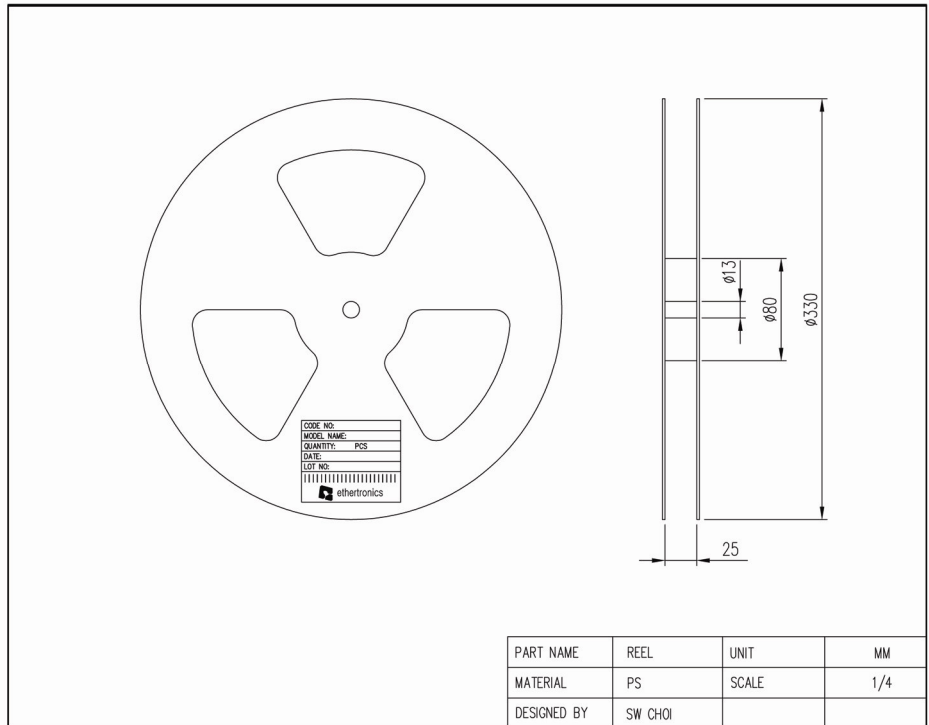
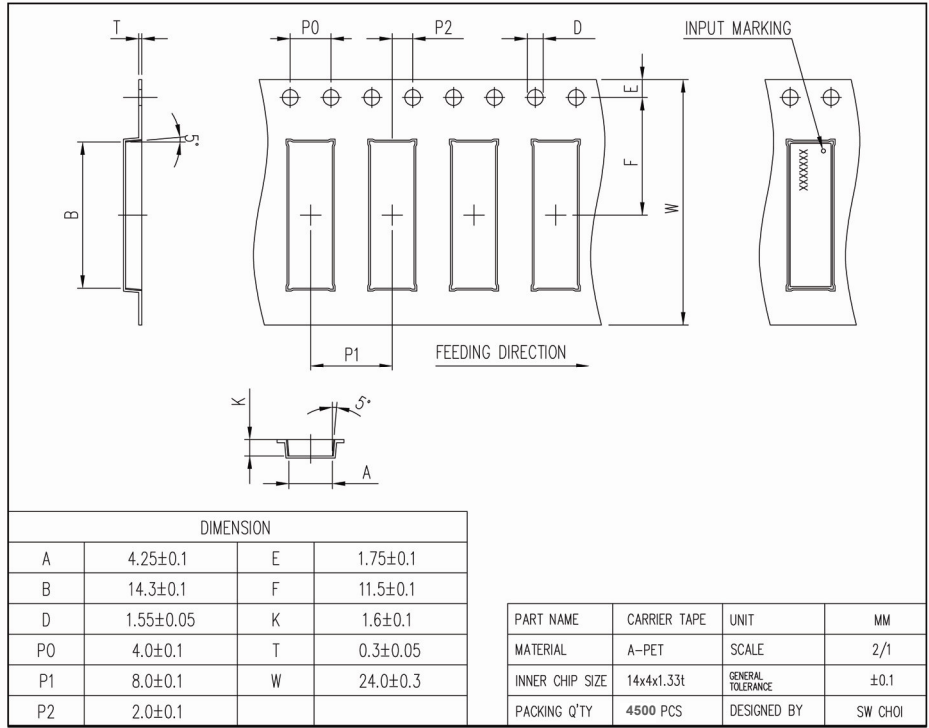

## Antenna Application Note

### Tape & Reel Specifications 12mm x 3mm

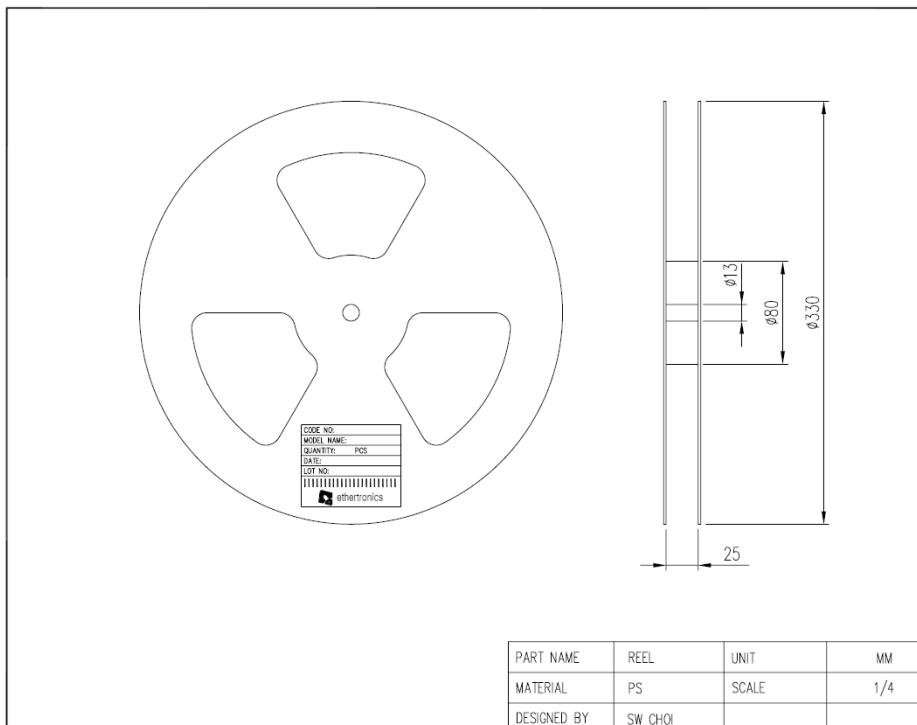
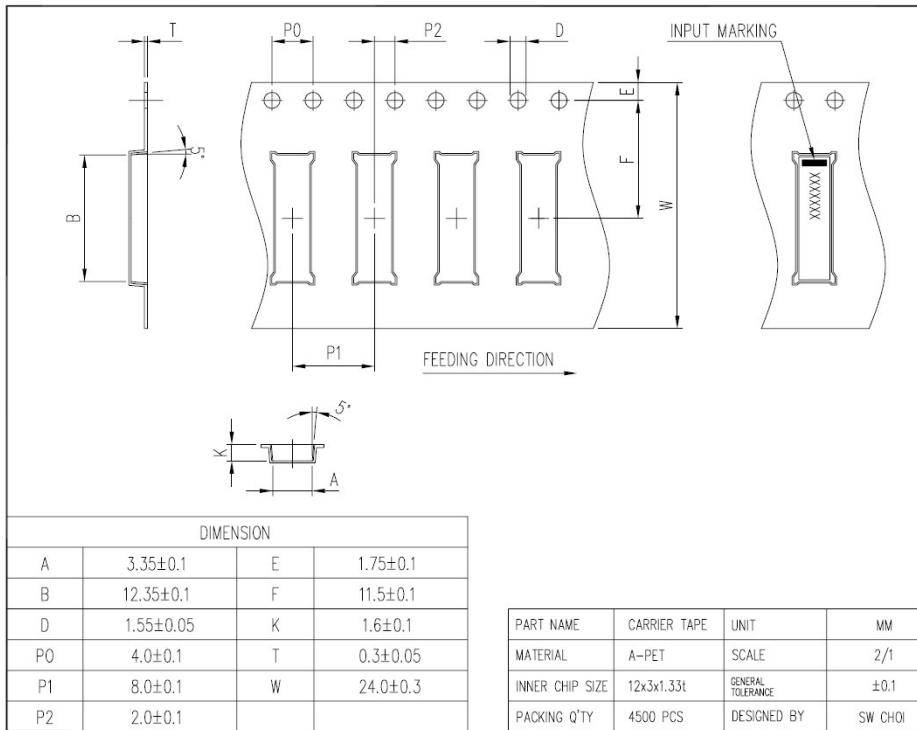

## Antenna Application Note

### Tape & Reel Specifications 10mm x 3mm

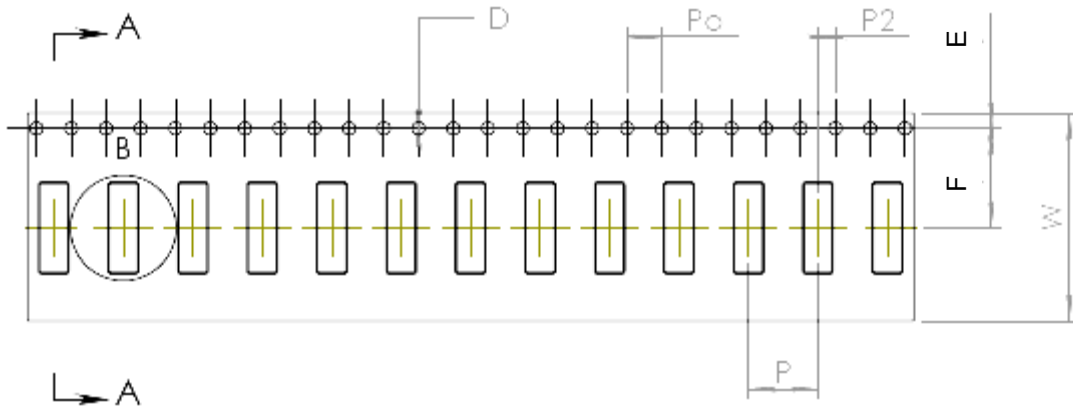

SECTION A-A

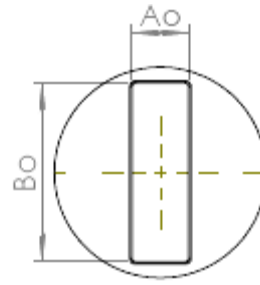

DETAIL B  
SCALE 2 : 1

	D		E		F		$D_1$	Po		P <sub>2</sub>	
MM	1.5	+0.10 -0.00	1.75	.10	11.5	±.10	N/A	4.0	±.10	2.0	±.10
INCHES	.059	+0.004 -.000	.069	±.004	.453	±.004	N/A	.157	±.004	.079	±.004

	T		W		P		Ao		Bo		Ko	
MM	.30	±.02	24	+0.3 -.1	8	±.1	3.25	±.10	10.3	±.10	1.6	±.10
INCHES	.012	±.0008	.945	+0.012 -.004	.315	±.004	.128	±.004	.406	±.004	.063	±.004

# Antenna Application Note

## Tape & Reel Specifications 8mm x 3mm

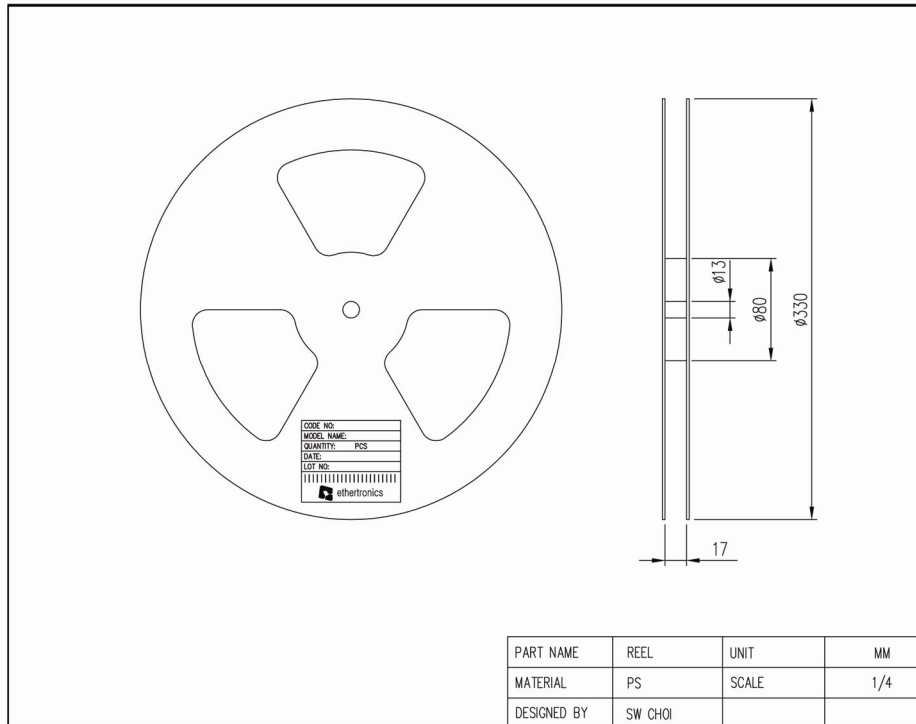
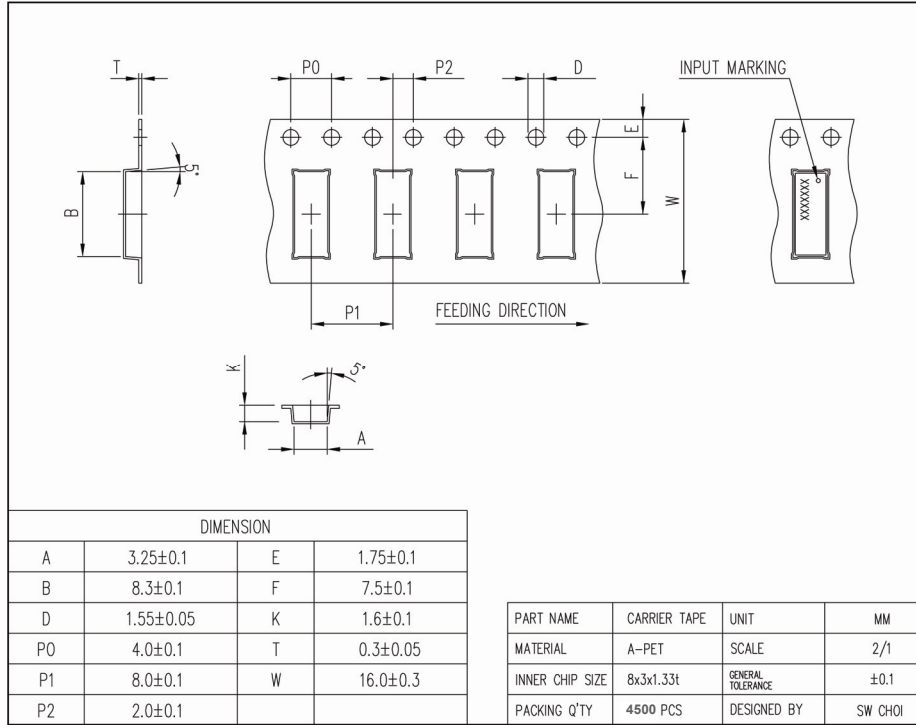

# Antenna Application Note

## Tape & Reel Specifications 6mm x 2mm

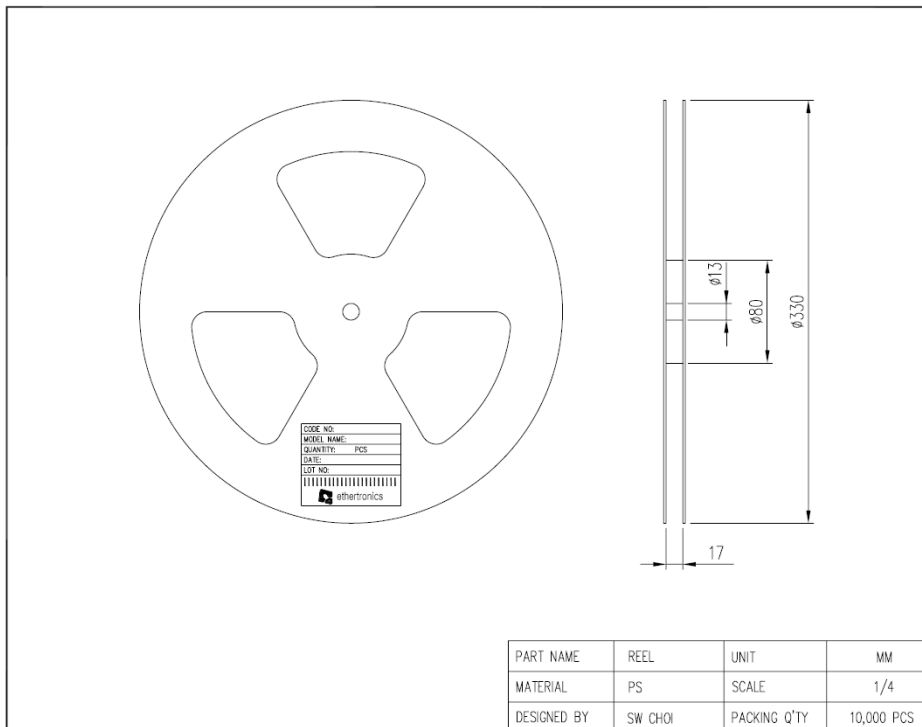
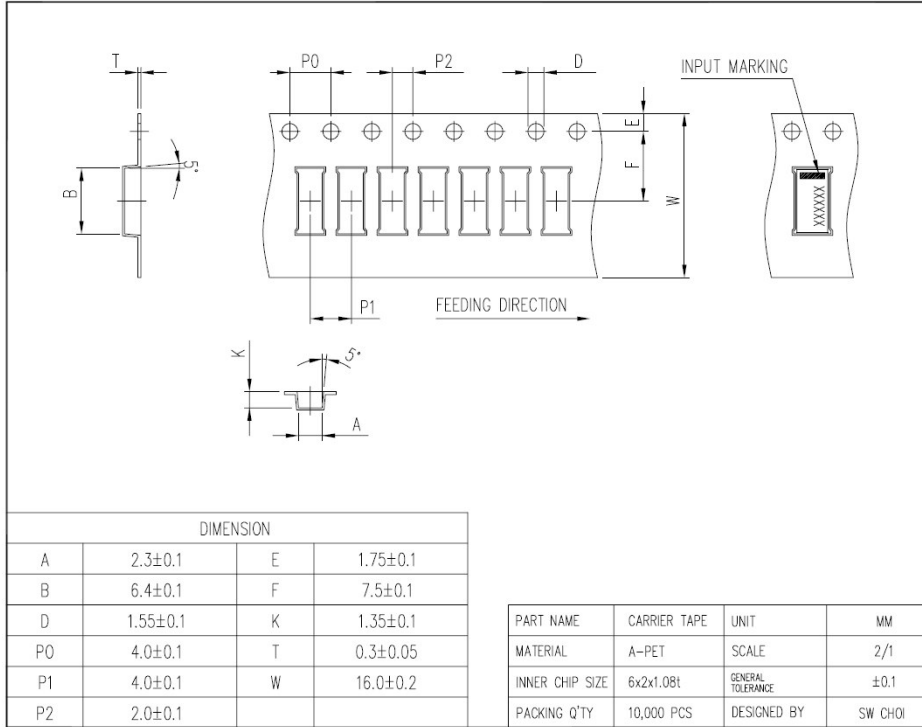

# Antenna Application Note

## Tape & Reel Specifications 5mm x 3mm

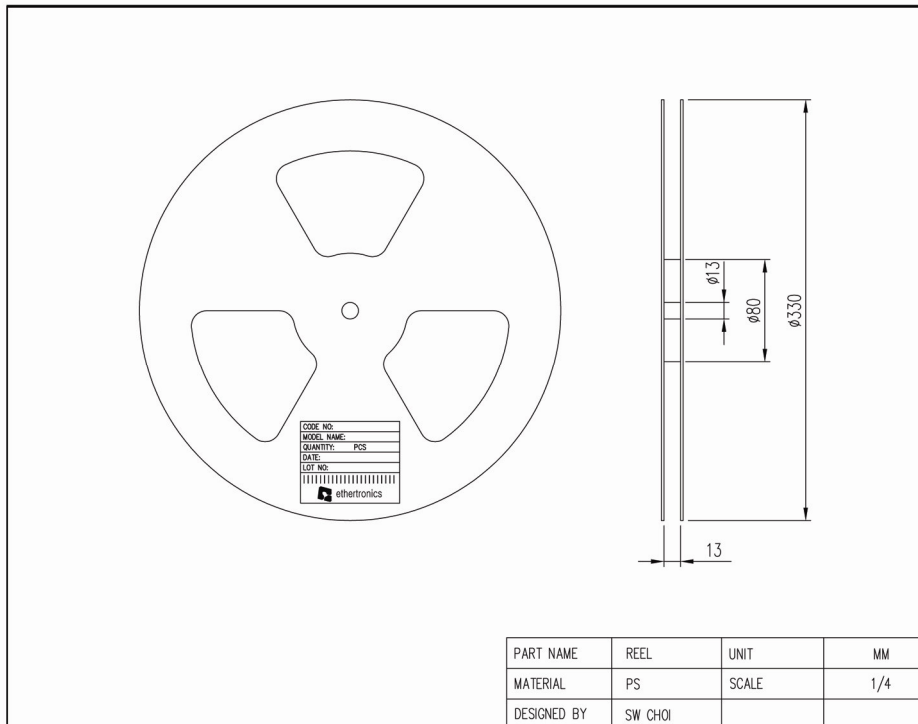
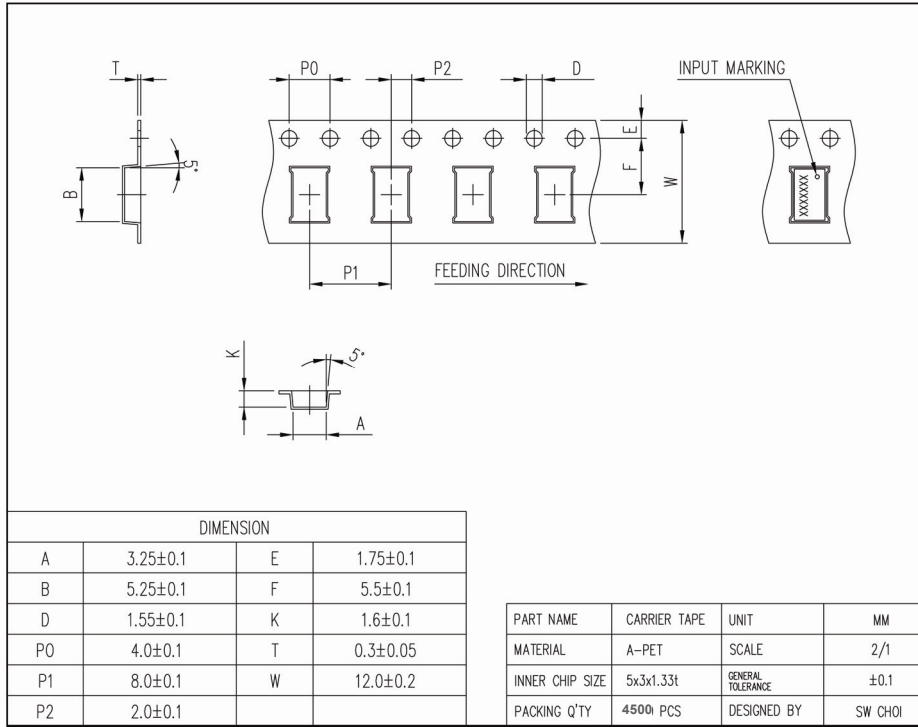

## Antenna Application Note

### Tape & Reel Specifications 4mm x 2mm

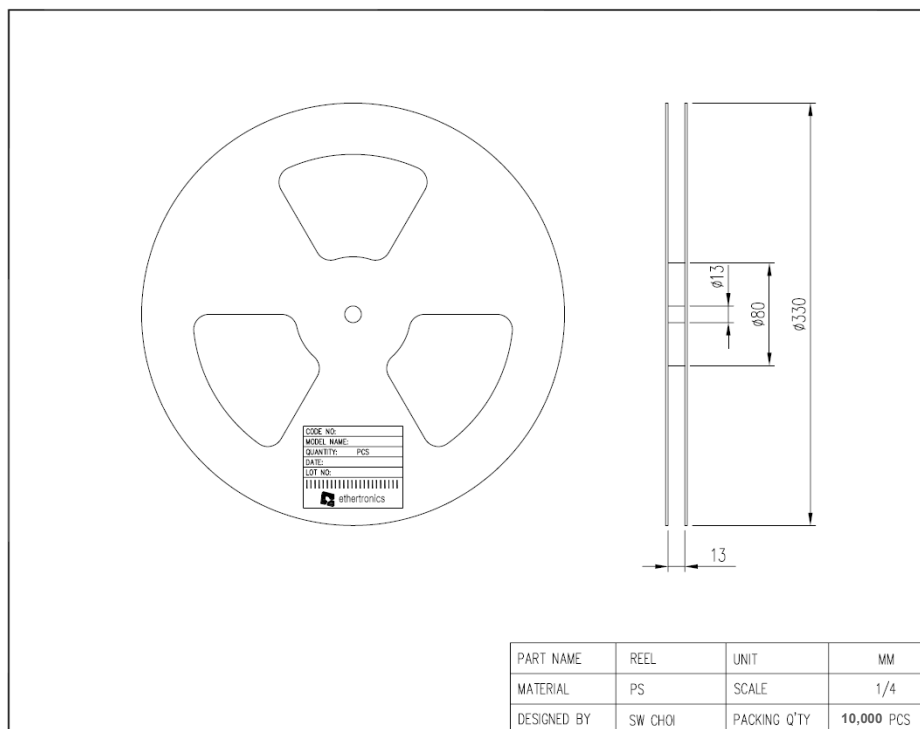
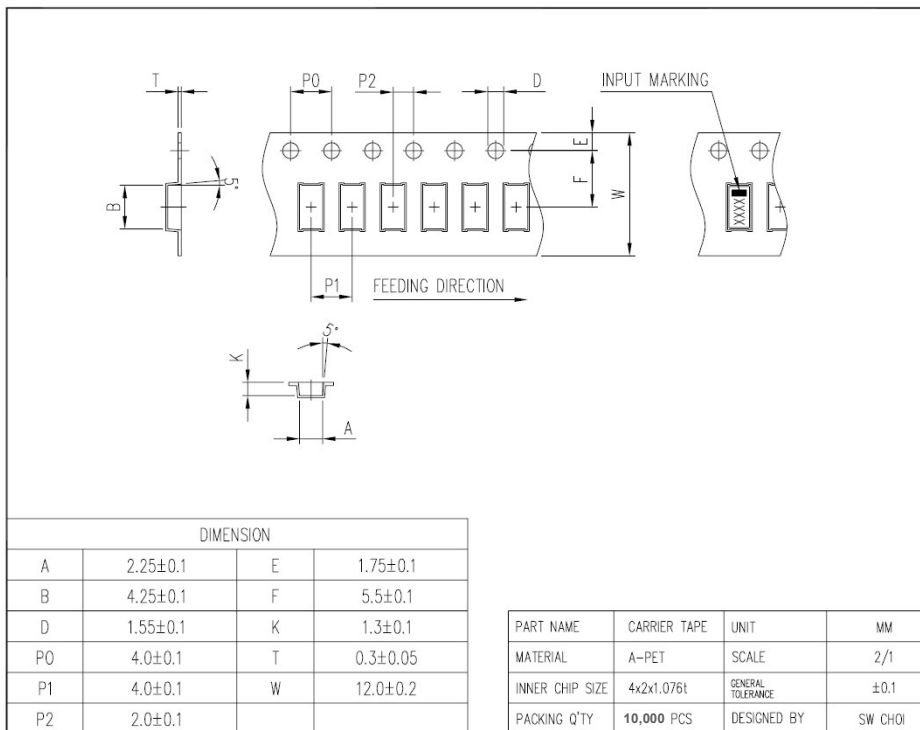

## Antenna Application Note

### Tape & Reel Specifications 3mm x 1.5mm

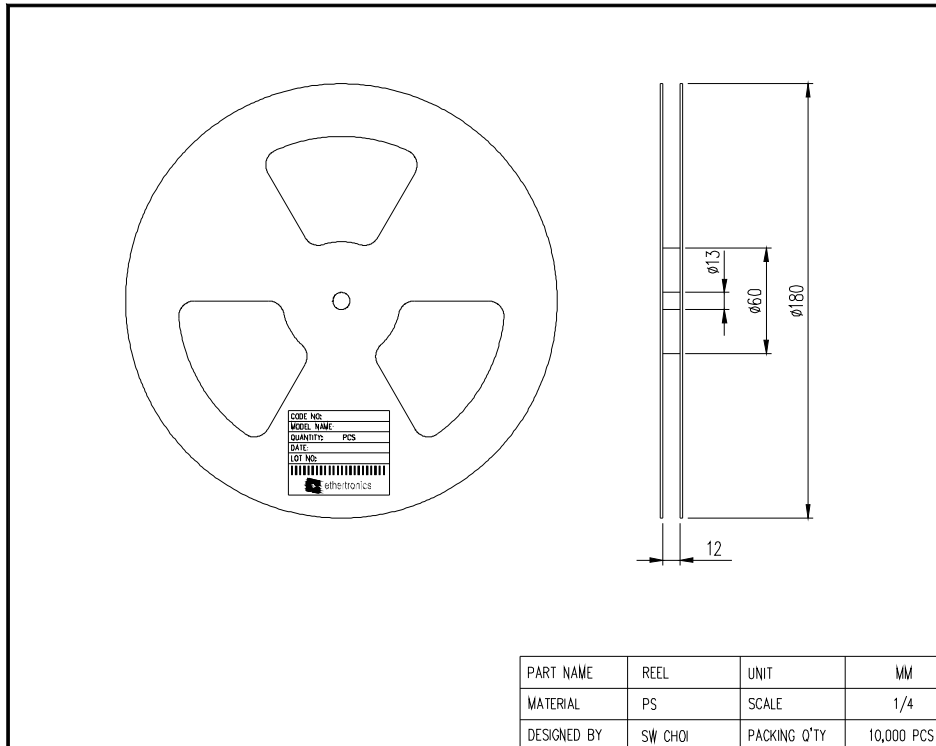
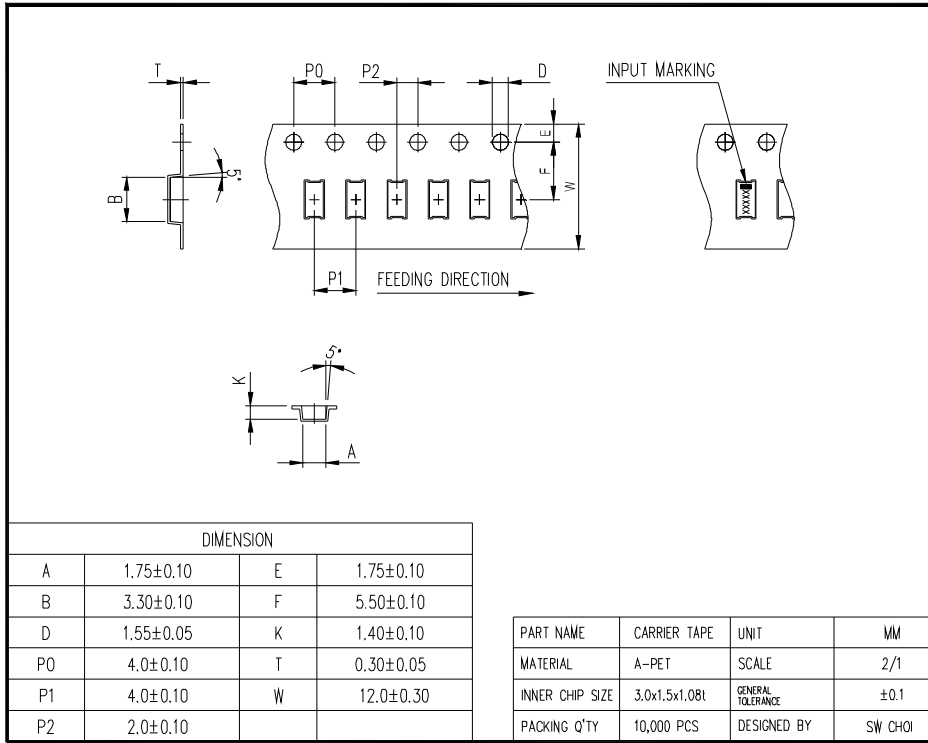

## Antenna Application Note

### Tape & Reel Specifications 2mm x 1.2mm

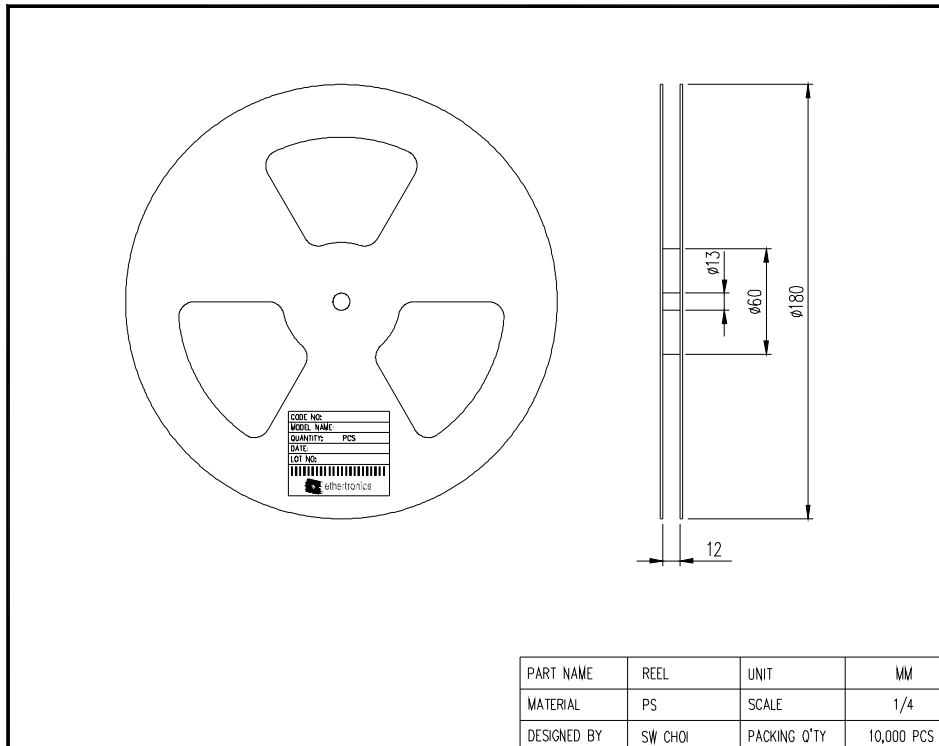
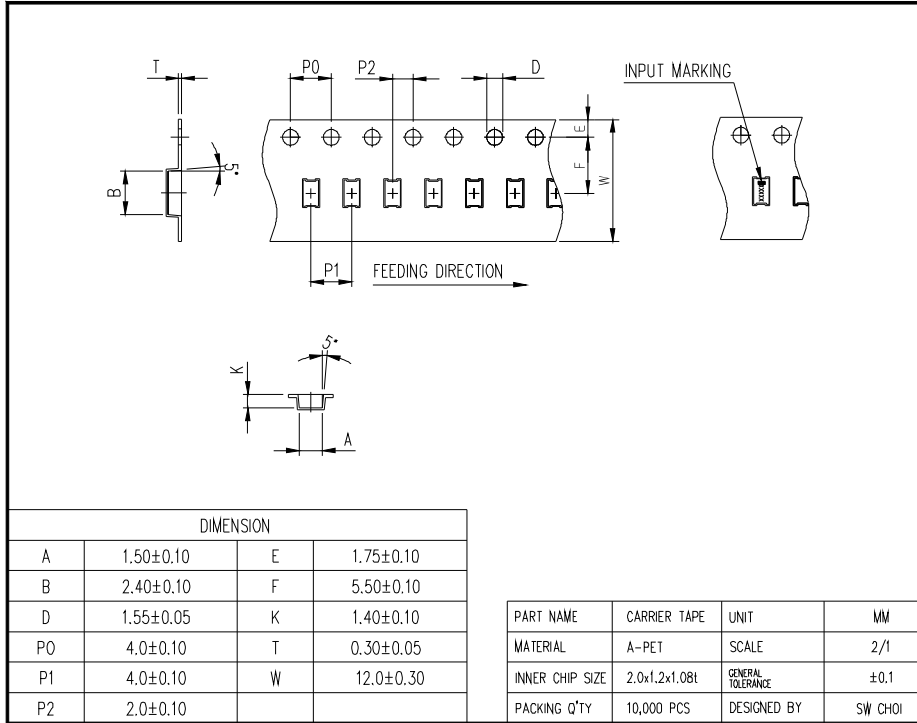

## Antenna Application Note

### 7. Product Definitions

#### 7.1 Product Date Code

The Savvi line of ceramic antennas include a printed code to indicate the manufacturing date. Figure 49, shows the date code marking for antennas 4x2mm or larger. Antennas 4x2mm or larger show the full Part Number. Figure 50 shows the date code marking for antennas 3x1.5mm or smaller. Antennas 3x1.5mm or smaller have a two digit code to indicate the Part Number.

Y = Year of Manufacture

9 = 2009

0 = 2010

1 = 2011

WW = Week of Manufacture

01 = Week 1

02 = Week 2

38 = Week 38

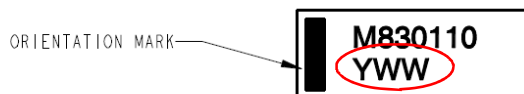

Figure 49

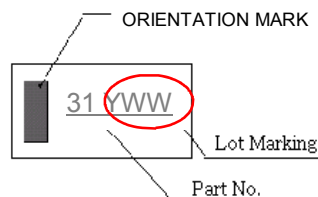

Figure 50

### 8. Glossary of Terms

For a complete list of terms, please visit the Ethertronics Web site at [www.ethertronics.com/resources/glossary/](http://www.ethertronics.com/resources/glossary/), or enter [http://files.ctia.org/pdf/Telecom\\_Glossary\\_of\\_Terms.pdf](http://files.ctia.org/pdf/Telecom_Glossary_of_Terms.pdf) into your browser.

# Antenna Application Note

## Appendix 1 Summary of Savvi™ 8x3mm GPS Ceramic Antenna Part No. M830110

### Electrical Specifications

Typical Characteristics

GPS Antenna	1.575 GHz
Peak Gain	1.78 dBi
Average Efficiency	75%
VSWR Match	1.7:1 max
Feed Point Impedance	50 Ω unbalanced
Power Handling	.5 Watt cw
Polarization	Linear

### Mechanical Specifications

Size	8x3x1.33mm
Mounting	Surface mount
Packaging	Tape & Reel

### Typical Efficiency, Return Loss

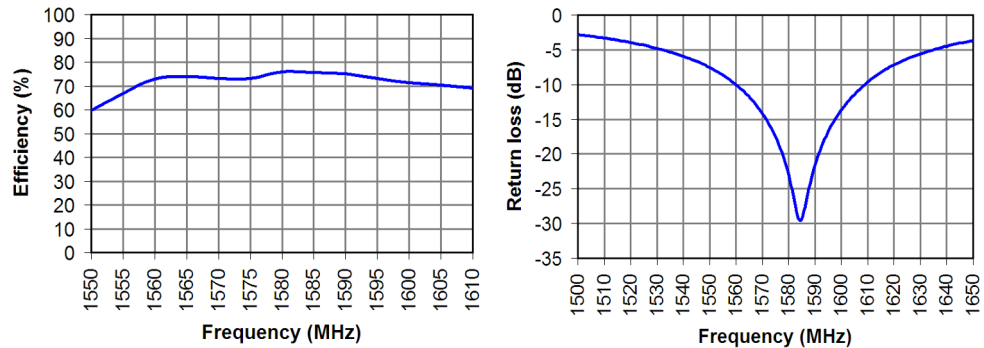

### Antenna Radiation Patterns

### 1.575 GHz Band

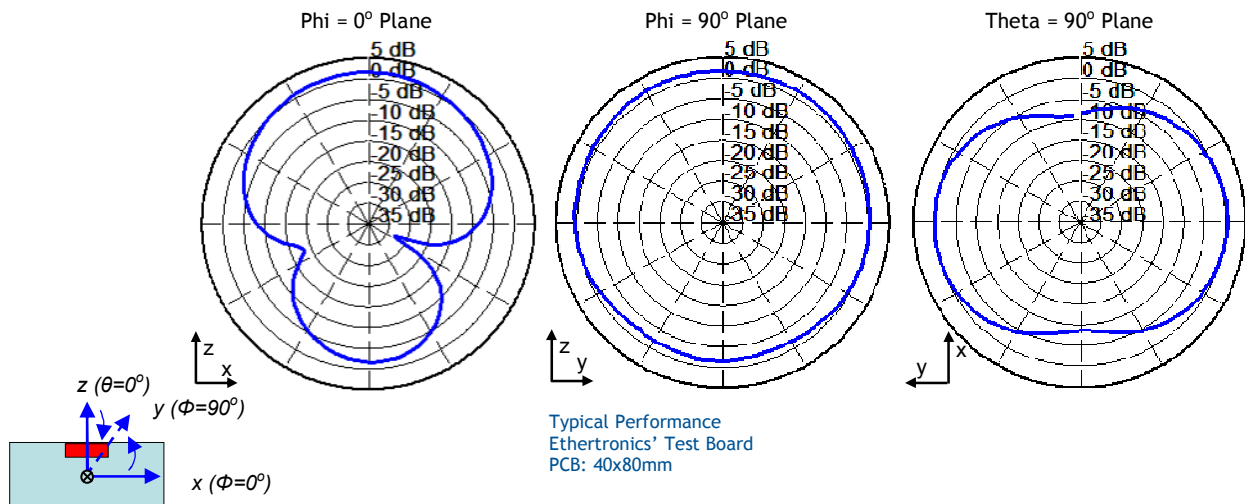

## Antenna Application Note

To optimize product designs using Ethertronics Savvi™ GPS single band antennas, the PCB should use the recommended land pattern shown in the Figures below. The land patterns are composed of a 50 ohm line connected to each antenna feed point. Ground clearance around and under the antenna, as shown in the PCB layout below, is recommended in order to maximize the antenna's performance. The antenna should be located along an edge of the PCB. The recommended default matching component value is 100pF.

### Antenna Pad Layout

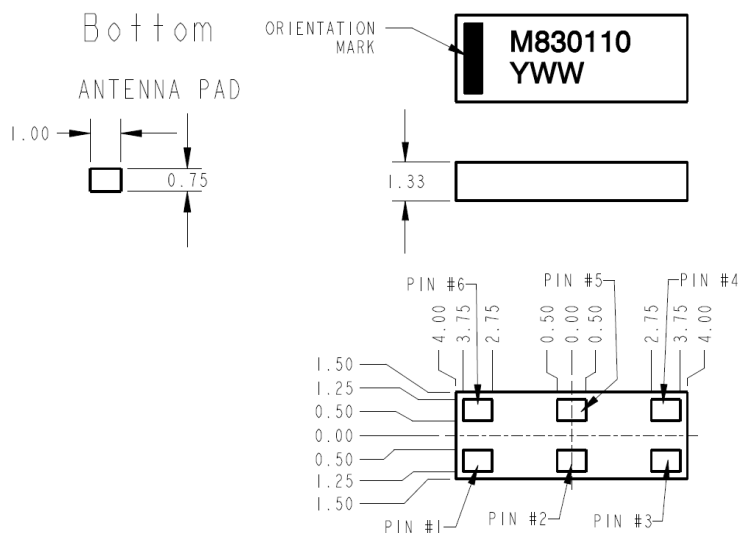

Pin	Description
1	Ground
2	Dummy Pad
3	Matching Circuit Connection
4	Dummy Pad
5	Dummy Pad
6	Ground/GPS Feed*

\*See page 20 for information on why the ground and feed line appear to be tied together.

### PCB Layout

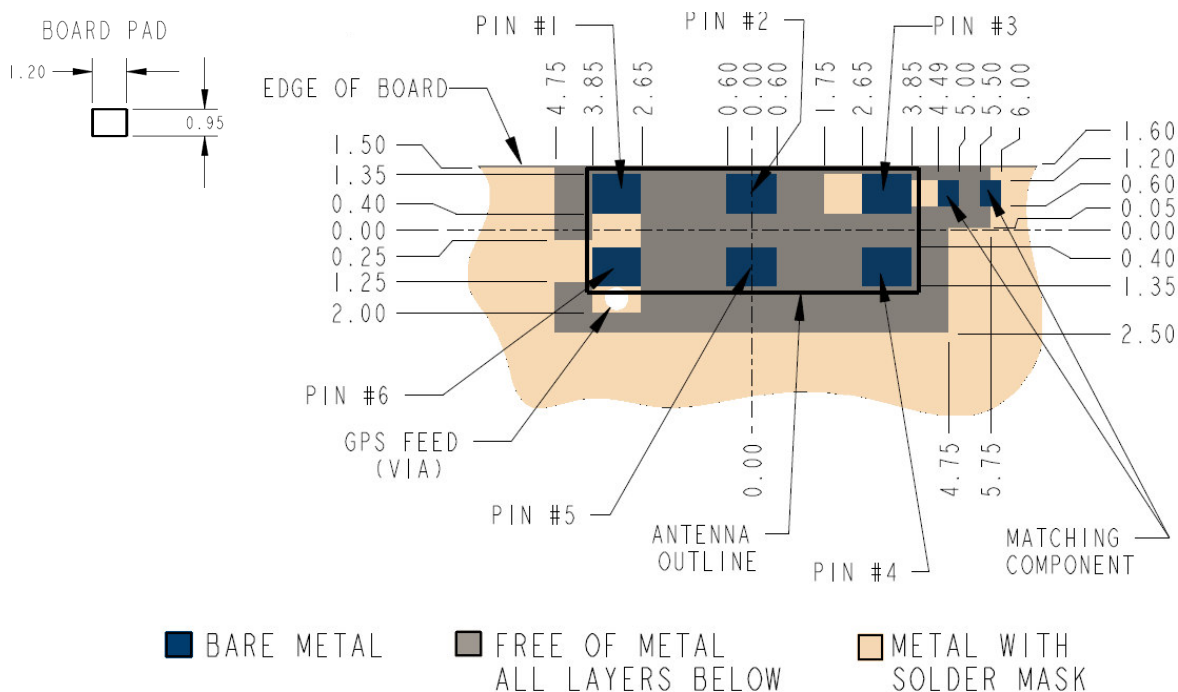

Ethertronics provides antenna layout files in .DXF format. This is a universal file format and should be converted into your specific file format

# Antenna Application Note

## Appendix 2 Summary of Savvi™ 4x2mm GPS Ceramic Antenna Part No. M420110

### Electrical Specifications

Typical Characteristics

GPS Antenna	1.575 GHz
Peak Gain	1.1 dBi
Average Efficiency	59%
VSWR Match	1.9:1 max
Feed Point Impedance	50 Ω unbalanced
Power Handling	.5 Watt cw
Polarization	Linear

### Mechanical Specifications

Size	4.00x2.00x1.08mm
Mounting	Surface mount
Packaging	Tape & Reel

### Typical Efficiency, Return Loss

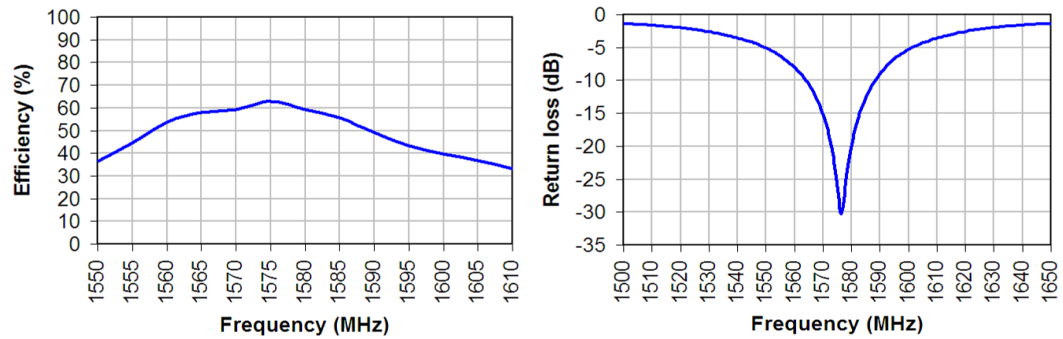

### Antenna Radiation Patterns

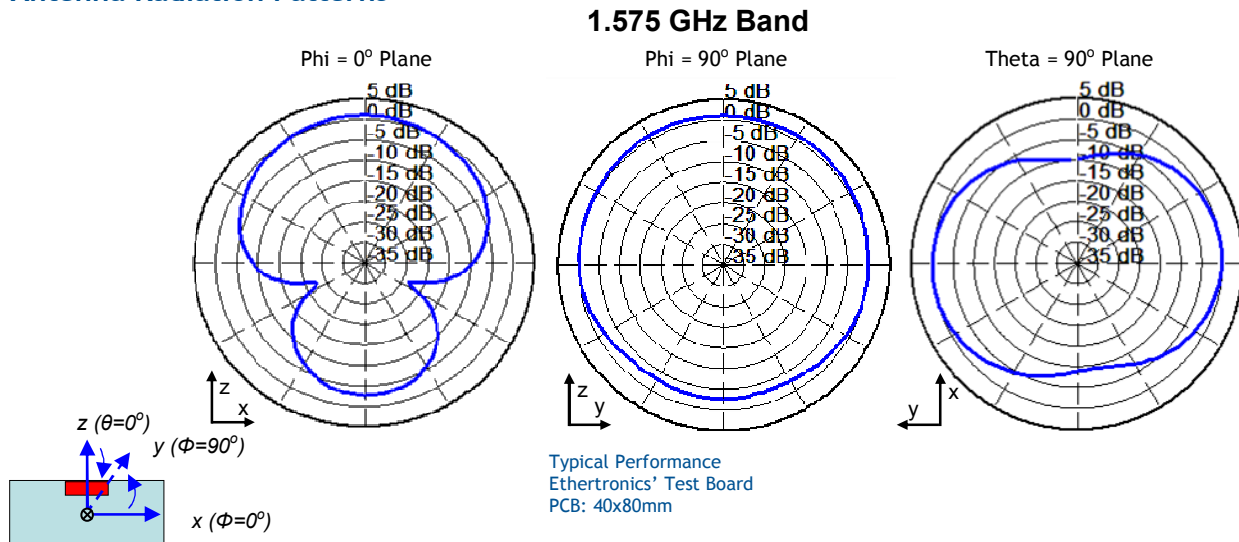

## Antenna Application Note

To optimize product designs using Ethertronics Savvi™ GPS single band antennas, the PCB should use the recommended land pattern shown in the Figures below. The land patterns are composed of a 50 ohm line connected to each antenna feed point. Ground clearance around and under the antenna, as shown in the PCB layout below, is recommended in order to maximize the antenna's performance. The antenna should be located along an edge of the PCB. The recommended default matching component value is 100pF.

### Antenna Pad Layout

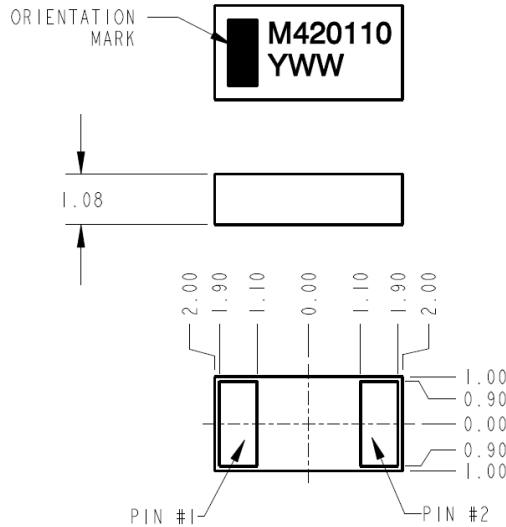
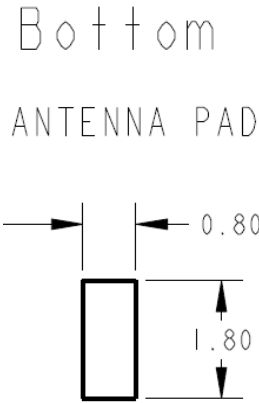

Pin	Description
1	Ground/GPS Feed*
2	Matching Circuit Connection

\*See page 20 for information on why the ground and feed line appear to be tied together.

### PCB Layout

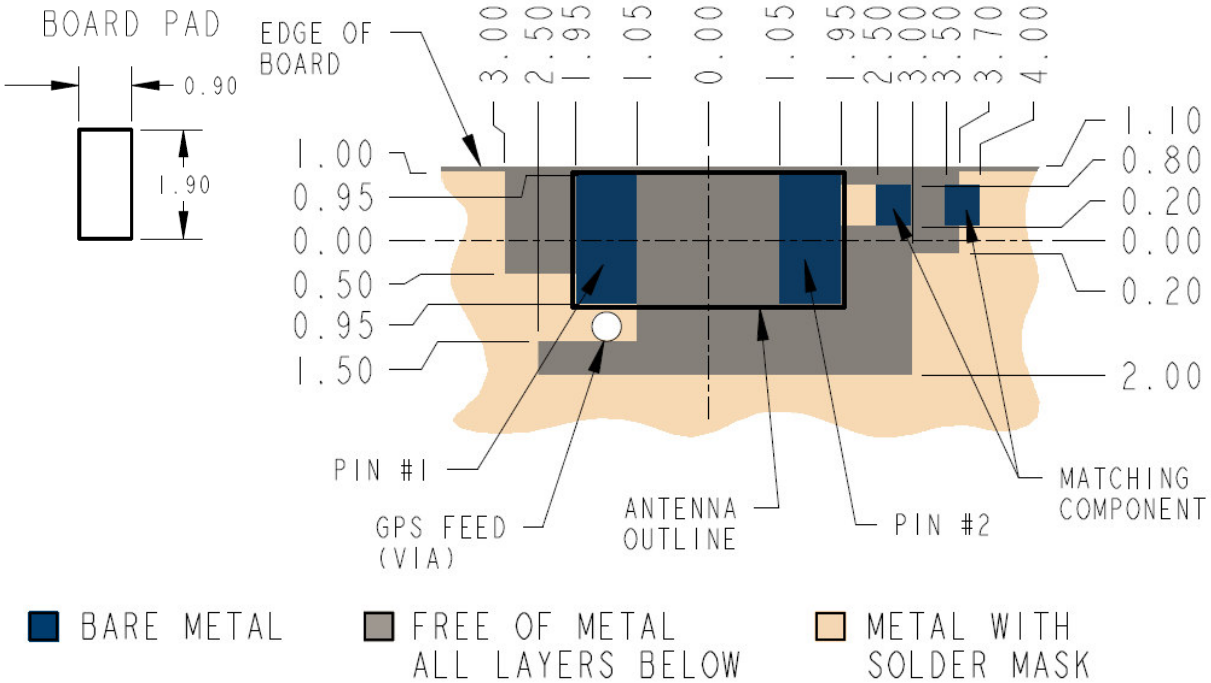

Ethertronics provides antenna layout files in .DXF format. This is a universal file format and should be converted into your specific file format

## Antenna Application Note

### Appendix 3 Summary of Savvi™ 3x1.5mm GPS Ceramic Antenna Part No. M310110

#### Electrical Specifications

Typical Characteristics

GPS Antenna	1.575 GHz
Peak Gain	1 dBi
Average Efficiency	63%
VSWR Match	1.3:1 max
Feed Point Impedance	50 $\Omega$ unbalanced
Power Handling	.5 Watt cw
Polarization	Linear

#### Mechanical Specifications

Size	3.00x1.50x1.08mm
Mounting	Surface mount
Packaging	Tape & Reel

#### Typical Efficiency, Return Loss

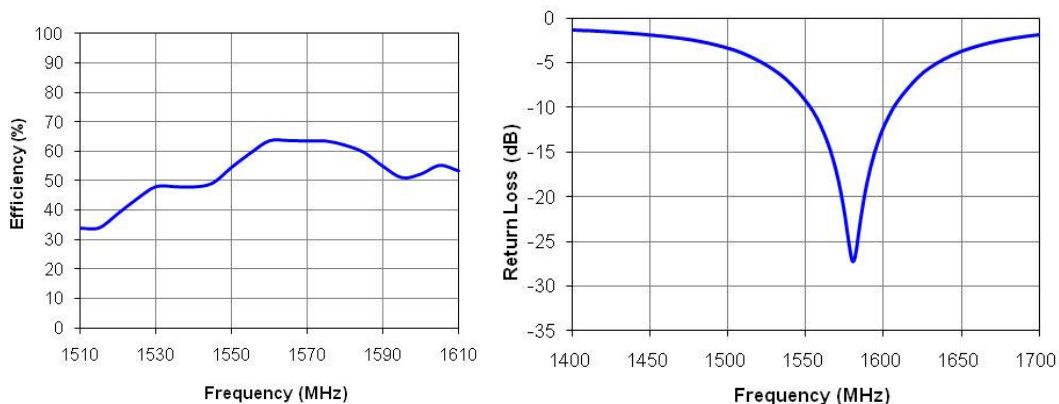

#### Antenna Radiation Patterns

#### 1.575 GHz Band

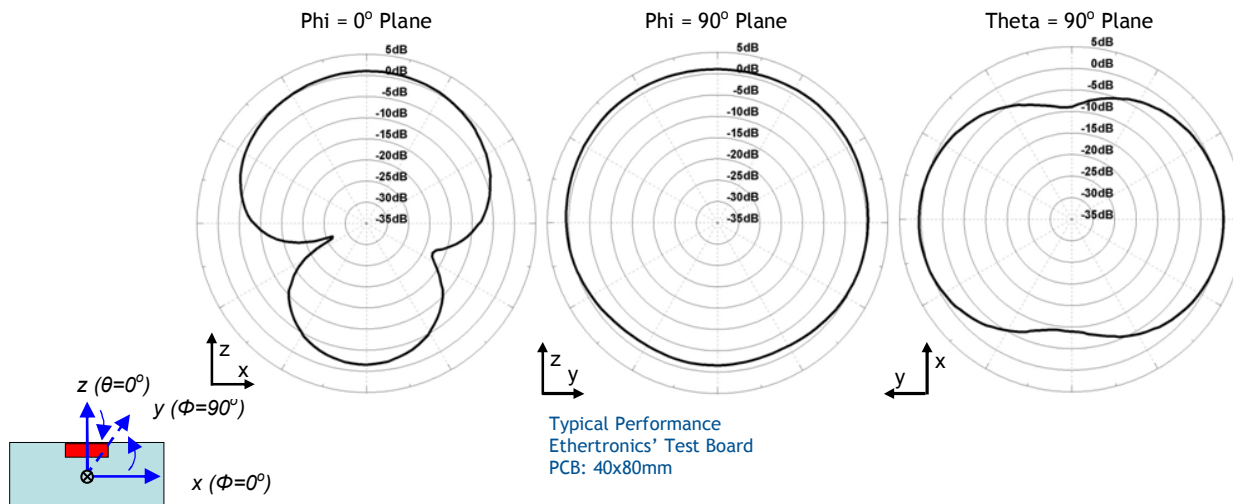



# Antenna Application Note

## Appendix 4 Summary of Savvi™ 2x1.2mm GPS Ceramic Antenna Part No. M210110

### Electrical Specifications

Typical Characteristics

GPS Antenna	1.575 GHz
Peak Gain	1dBi
Average Efficiency	65%
VSWR Match	1.5:1 max
Feed Point Impedance	50 Ω unbalanced
Power Handling	.5 Watt cw
Polarization	Linear

### Mechanical Specifications

Size	2.00x1.20x1.08mm
Mounting	Surface mount
Packaging	Tape & Reel

### Typical Efficiency, Return Loss

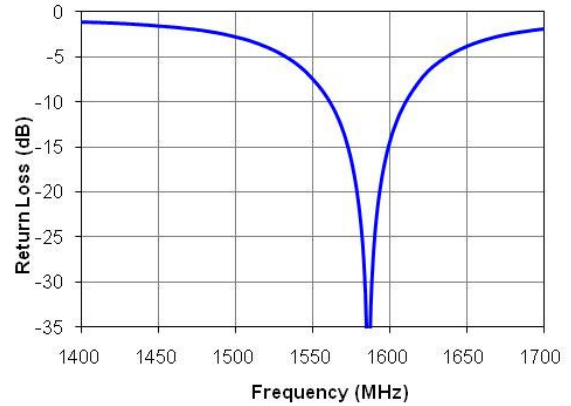
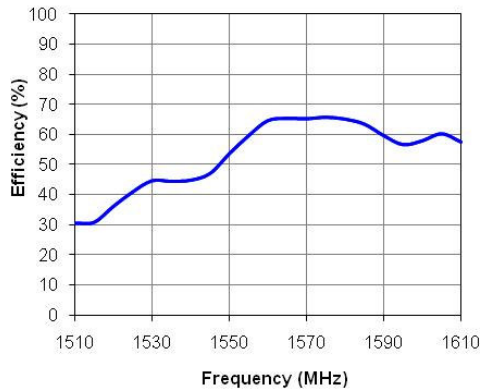

### Antenna Radiation Patterns

#### 1.575 GHz Band

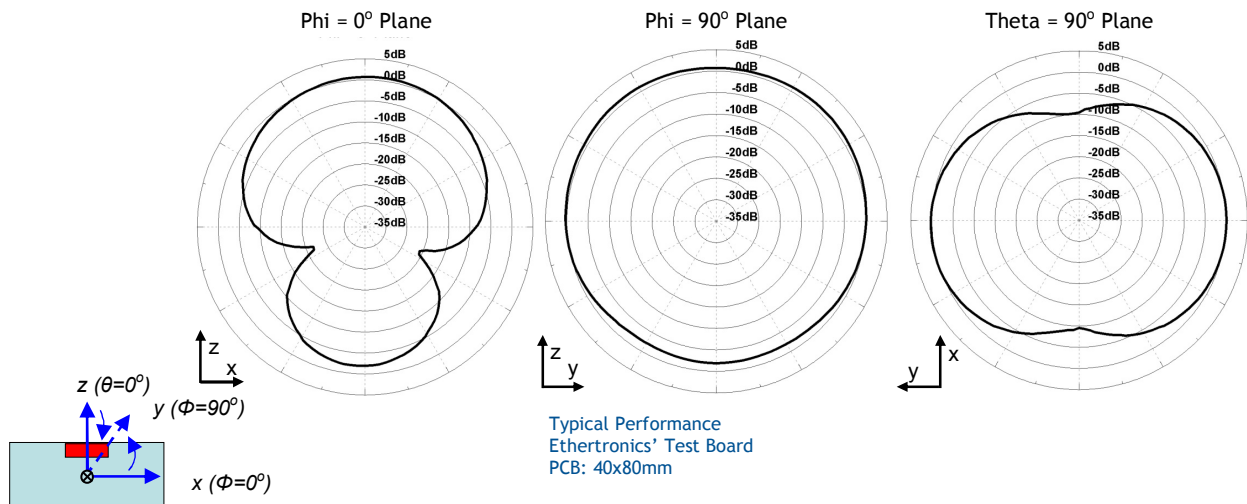

## Antenna Application Note

To optimize product designs using Ethertronics Savvi™ GPS single band antennas, the PCB should use the recommended land pattern shown in the Figures below. The land patterns are composed of a 50 ohm line connected to each antenna feed point. Ground clearance around and under the antenna, as shown in the PCB layout below, is recommended in order to maximize the antenna's performance. The antenna should be located along an edge of the PCB.

\*Note: Please see Tuning Guidelines (page 14) for more information on the matching circuit.

### Antenna Pad Layout

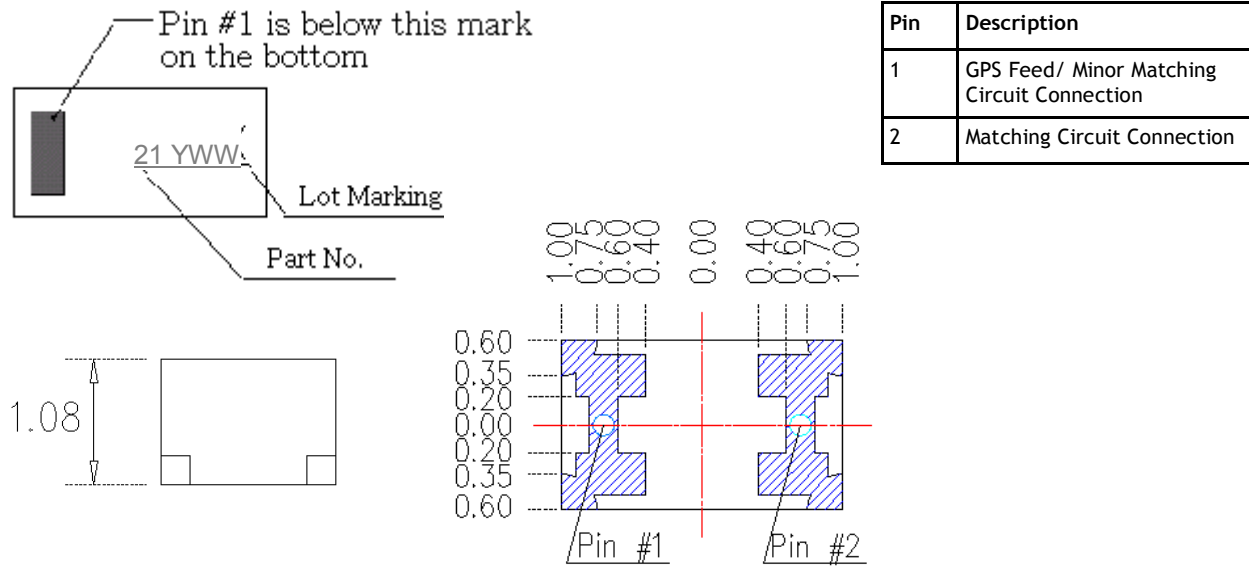

### PCB Layout

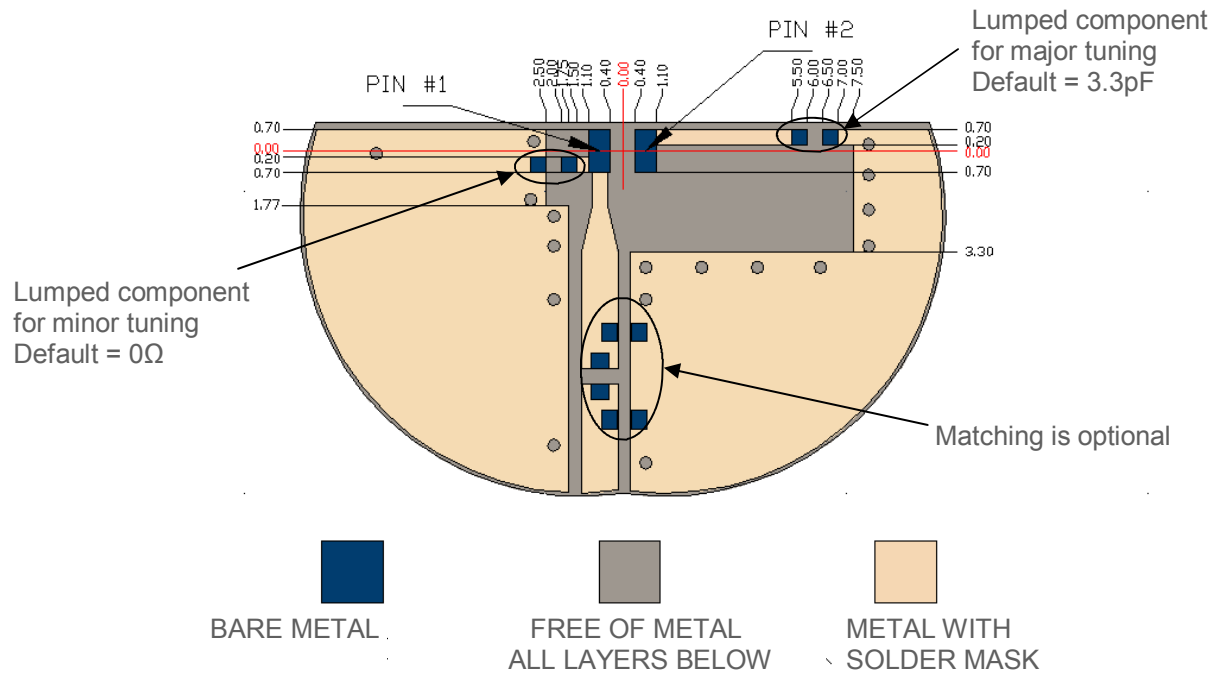

Ethertronics provides antenna layout files in .DXF format. This is a universal file format and should be converted into your specific file format

## Antenna Application Note

### Appendix 5 Summary of Savvi™ 8x3mm Bluetooth® Ceramic Antenna Part No. M830310

#### Electrical Specifications

Typical Characteristics

BT Antenna	2.4–2.5 GHz
Peak Gain	1.39 dBi
Average Efficiency	78%
VSWR Match	2.0:1 max
Feed Point Impedance	50 Ω unbalanced
Power Handling	.5 Watt cw
Polarization	Linear

#### Mechanical Specifications

Size	8x3x1.33mm
Mounting	Surface mount
Packaging	Tape & Reel

#### Typical Efficiency, Return Loss

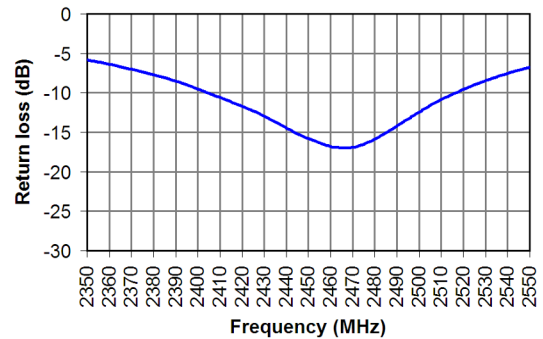
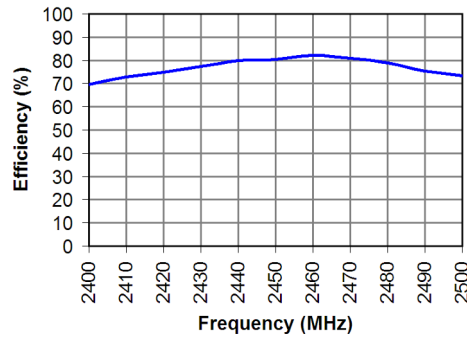

#### Antenna Radiation Patterns

#### 2.4 GHz Band

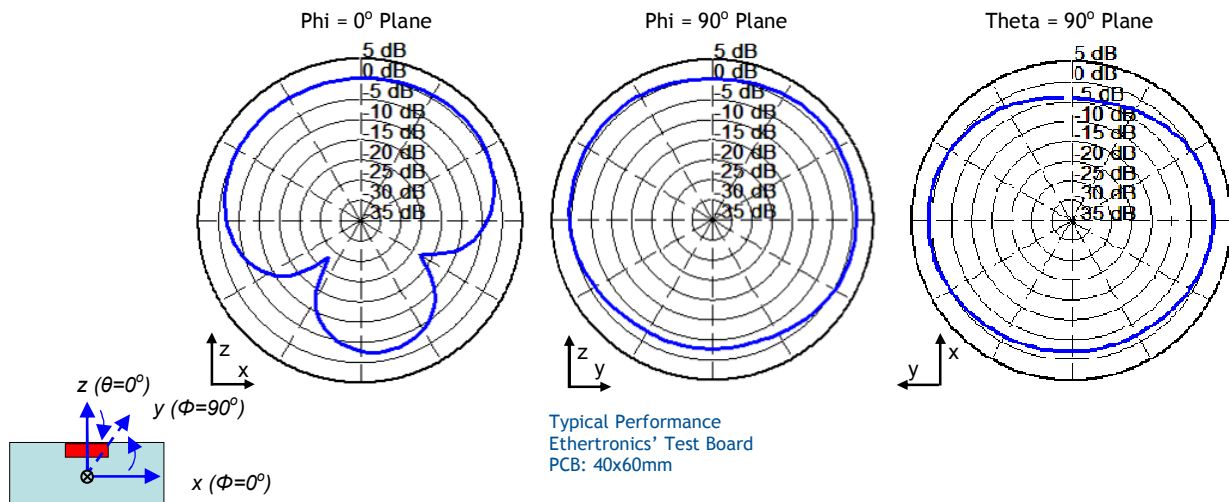

## Antenna Application Note

To optimize designs using Ethertronics' Savvi™ Bluetooth® single band antenna, the PCB should use the recommended land pattern shown in the Figures below. The land patterns are composed of a 50 ohm line connected to each antenna feed point. Ground clearance around and under the antenna, as shown in the PCB layout below, is recommended in order to maximize the antenna's performance. The antenna should be located along an edge of the PCB. The recommended default matching component value is 100pF.

### Antenna Pad Layout

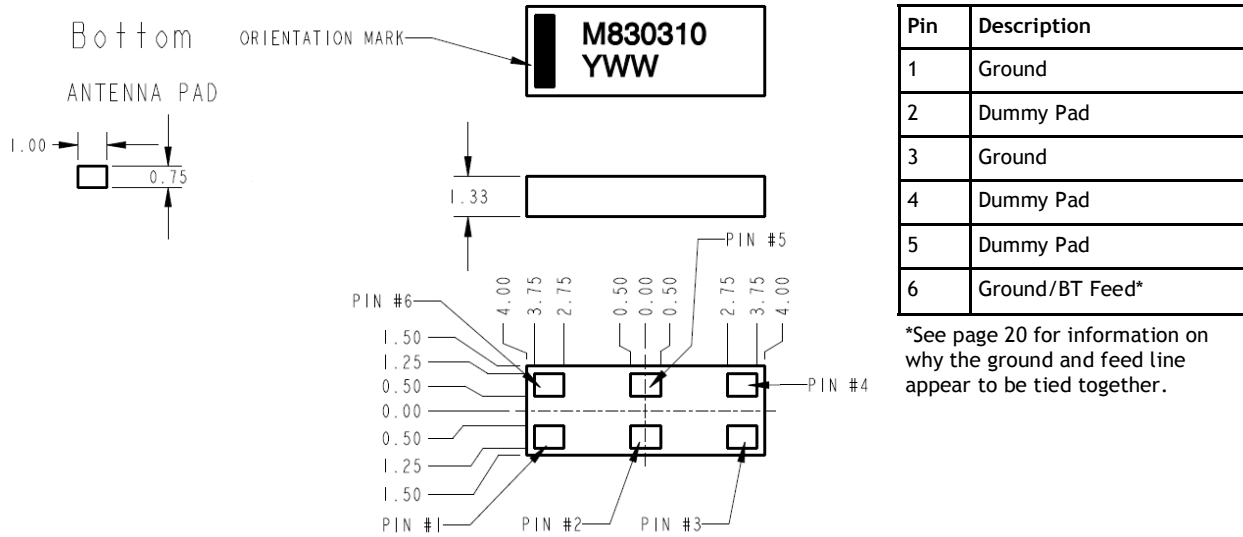

### PCB Layout

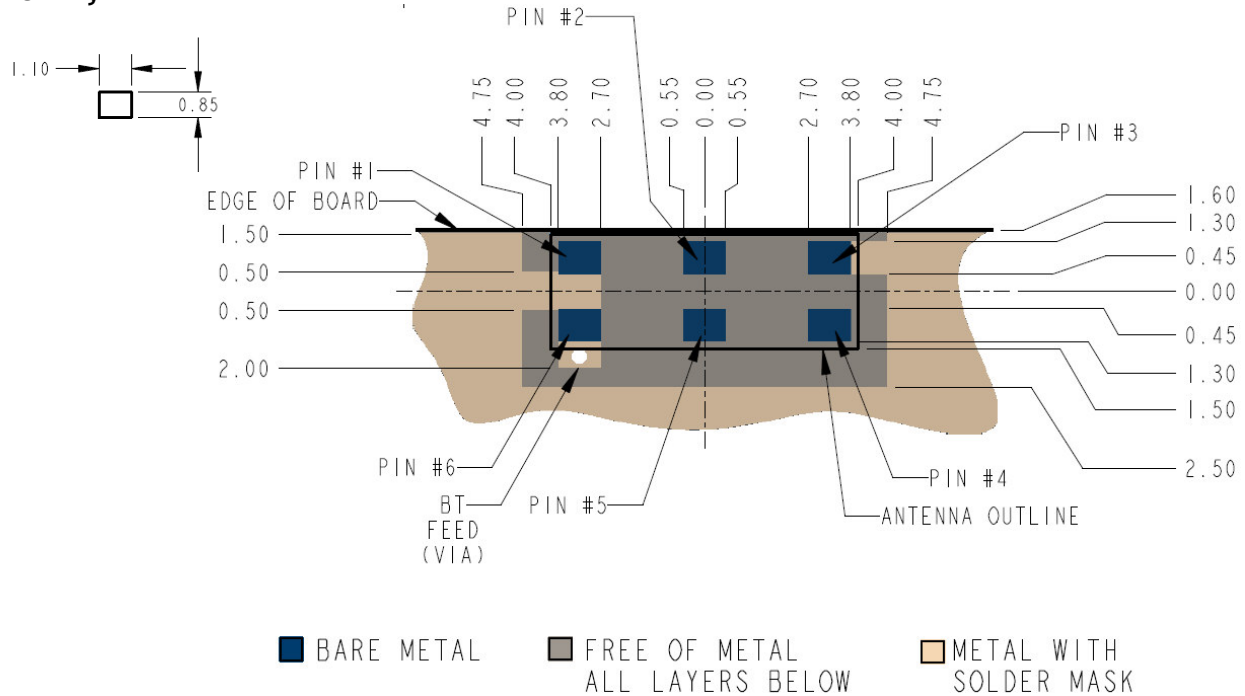

Ethertronics provides antenna layout files in .DXF format. This is a universal file format and should be converted into your specific file format

## Antenna Application Note

### Appendix 6

### Summary of Savvi™ 6x2mm Bluetooth® Ceramic Antenna Part No. M620310

#### Electrical Specifications

Typical Characteristics

BT Antenna	2.4–2.5 GHz
Peak Gain	.4 dBi
Average Efficiency	58%
VSWR Match	3:1 max
Feed Point Impedance	50 Ω unbalanced
Power Handling	0.5 Watt cw
Polarization	Linear

#### Mechanical Specifications

Size	6.00x2.00x1.08mm
Mounting	Surface mount
Packaging	Tape & Reel

#### Typical Efficiency, Return Loss

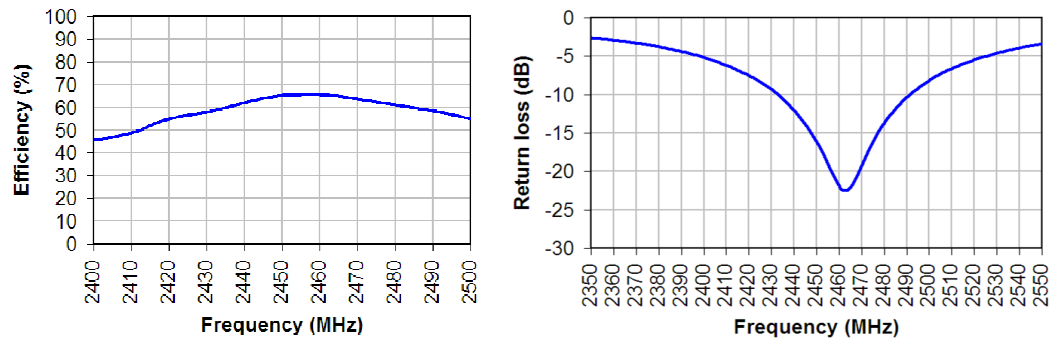

#### Antenna Radiation Patterns

#### 2.4 GHz Band

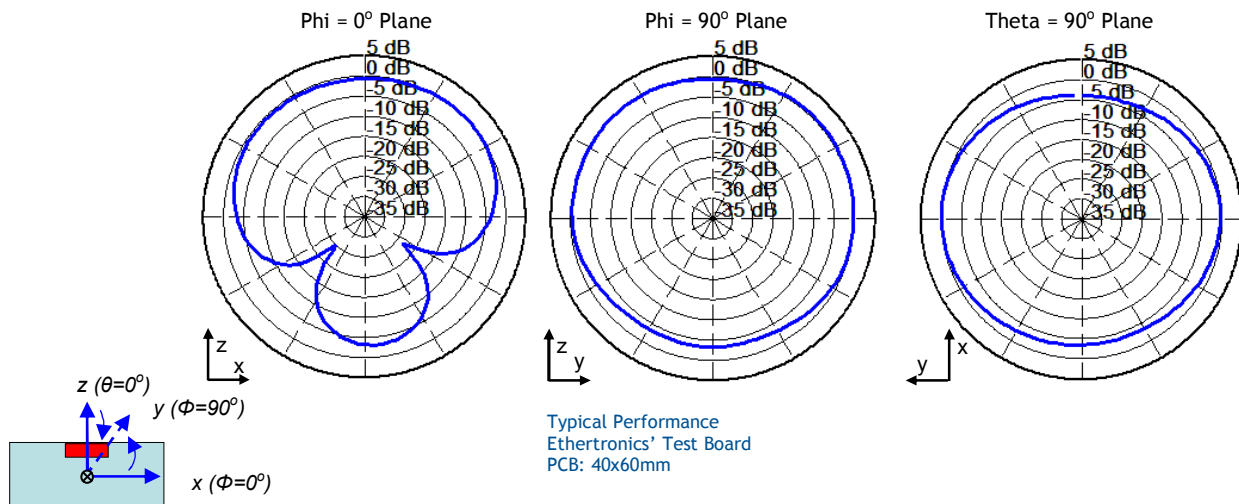

## Antenna Application Note

To optimize designs using Ethertronics' Savvi™ Bluetooth® single band antenna, the PCB should use the recommended land pattern shown in the Figures below. The land patterns are composed of a 50 ohm line connected to each antenna feed point. Ground clearance around and under the antenna, as shown in the PCB layout below, is recommended in order to maximize the antenna's performance. The antenna should be located along an edge of the PCB.

\*Note: contact Ethertronics for more information on the matching circuit.

### Antenna Pad Layout

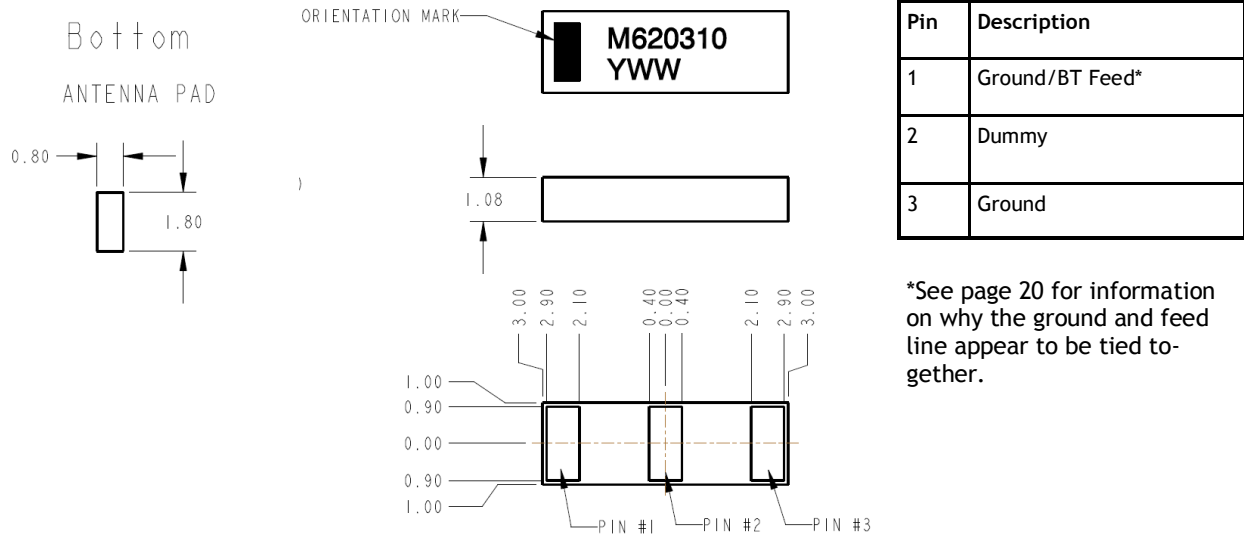

### PCB Layout

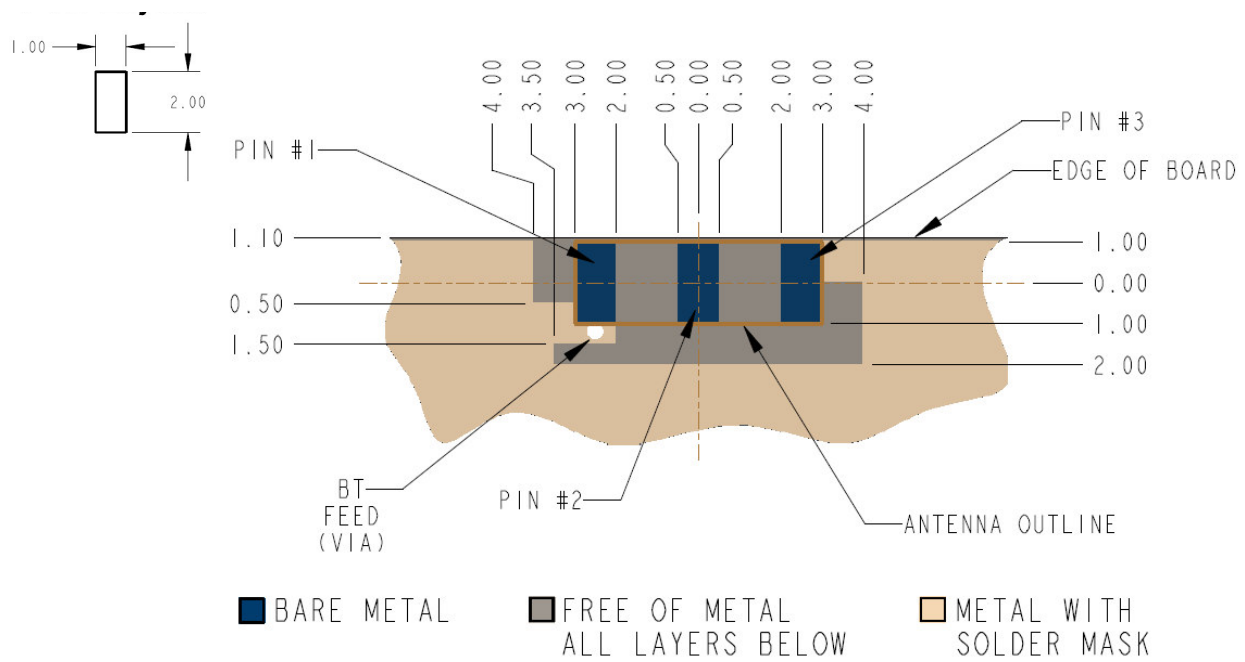

Ethertronics provides antenna layout files in .DXF format. This is a universal file format and should be converted into your specific file format

## Antenna Application Note

### Appendix 7 Summary of Savvi™ 6x2mm Bluetooth® Ceramic Antenna Part No. M620350

#### Electrical Specifications

Typical Characteristics

BT Antenna	2.4–2.5 GHz
Peak Gain	1.8dBi
Average Efficiency	64%
VSWR Match	1.3:1 max
Feed Point Impedance	50 Ω unbalanced
Power Handling	0.5 Watt cw
Polarization	Linear

#### Mechanical Specifications

Size	6.00x2.00x.96mm
Mounting	Surface mount
Packaging	Tape & Reel

#### Typical Efficiency, Return Loss

The M420370 antenna requires a matching circuit for proper use in the 2.4 GHz band. Please contact Ethertronics for details.

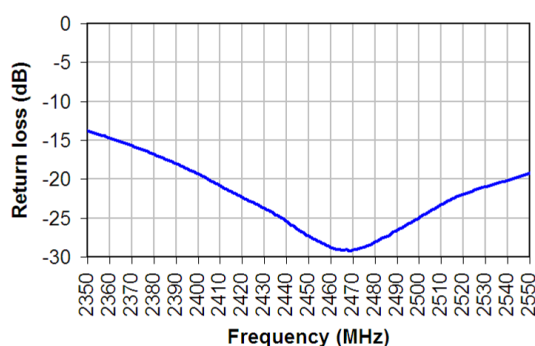
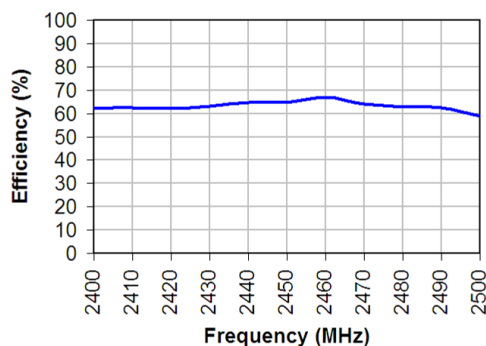

#### Antenna Radiation Patterns

#### 2.4 GHz Band

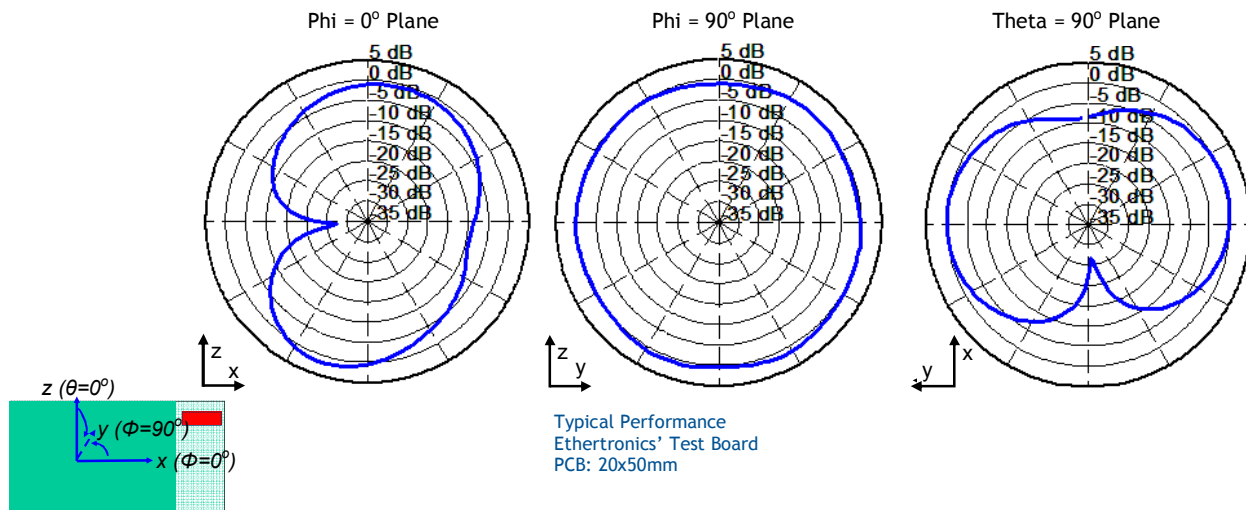

## Antenna Application Note

To optimize designs using Ethertronics' Savvi™ Bluetooth® single band antenna, the PCB should use the recommended land pattern shown in the Figures below. The land patterns are composed of a 50 ohm line connected to each antenna feed point. Ground clearance under the antenna, as shown in the PCB layout below, is recommended in order to maximize the antenna's performance. The antenna should be located along an edge of the PCB.

\*Note: contact Ethertronics for more information on the matching circuit.

### Antenna Pad Layout

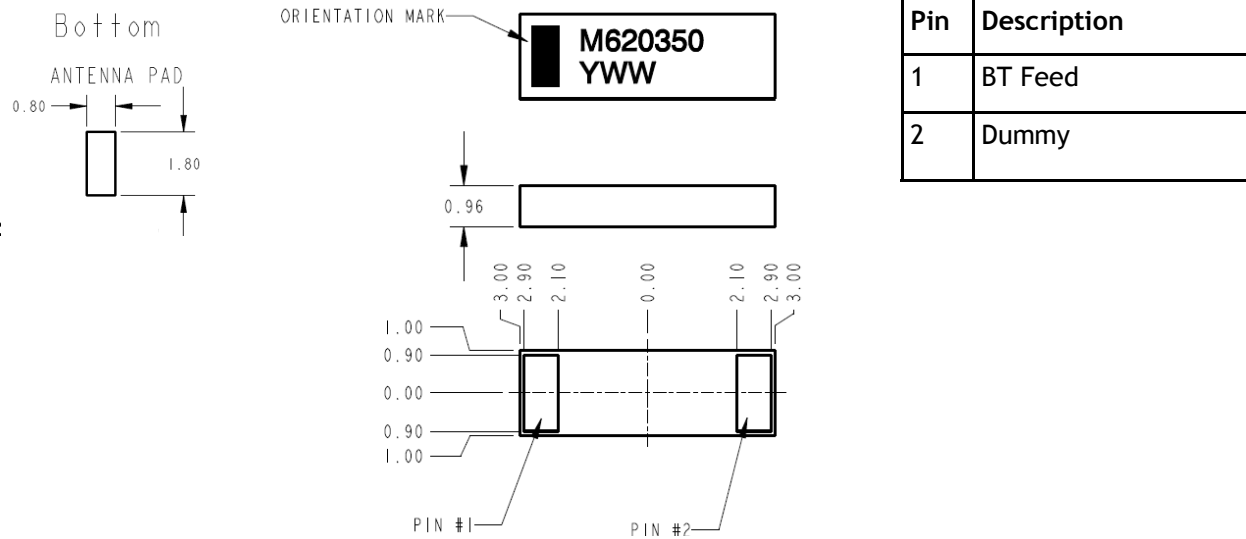

### PCB Layout

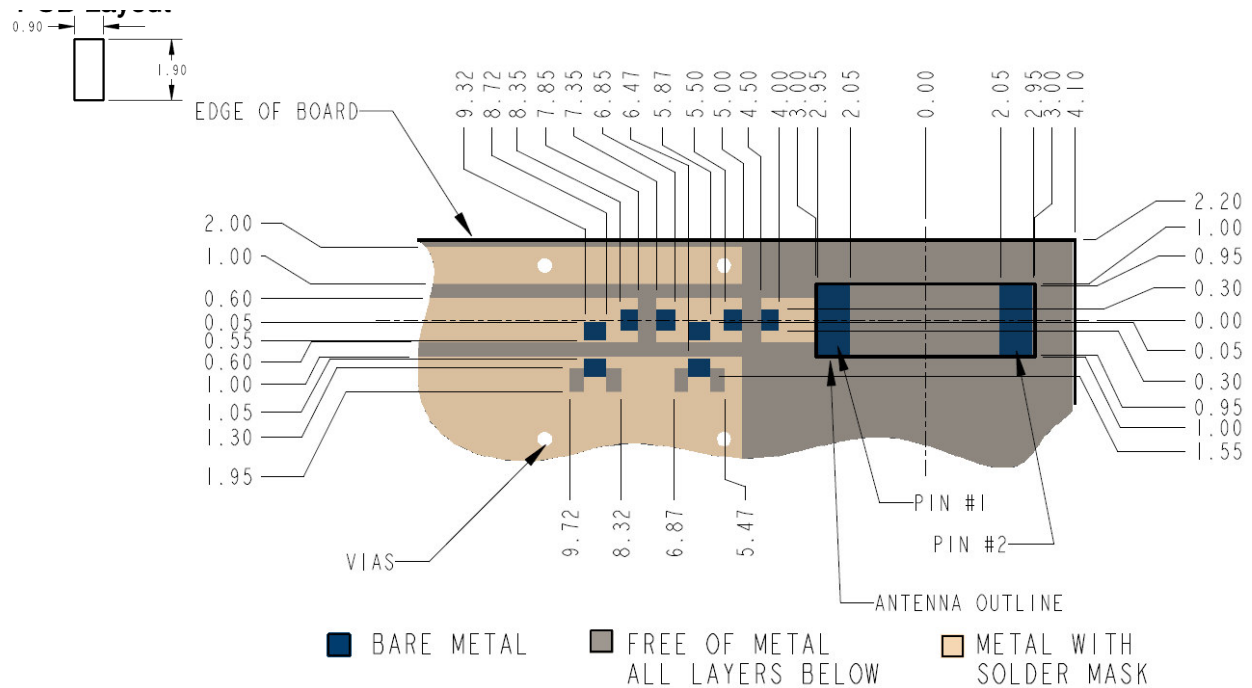

Ethertronics provides antenna layout files in .DXF format. This is a universal file format and should be converted into your specific file format

## Antenna Application Note

### Appendix 8

### Summary of Savvi™ 5x3mm Bluetooth® Ceramic Antenna Part No. M530310

#### Electrical Specifications

Typical Characteristics

BT Antenna	2.4–2.5 GHz
Peak Gain	1.3 dBi
Average Efficiency	72%
VSWR Match	2.5:1 max
Feed Point Impedance	50 Ω unbalanced
Power Handling	0.5 Watt cw
Polarization	Linear

#### Mechanical Specifications

Size	5x3x1.08mm
Mounting	Surface mount
Packaging	Tape & Reel

#### Typical Efficiency, Return Loss

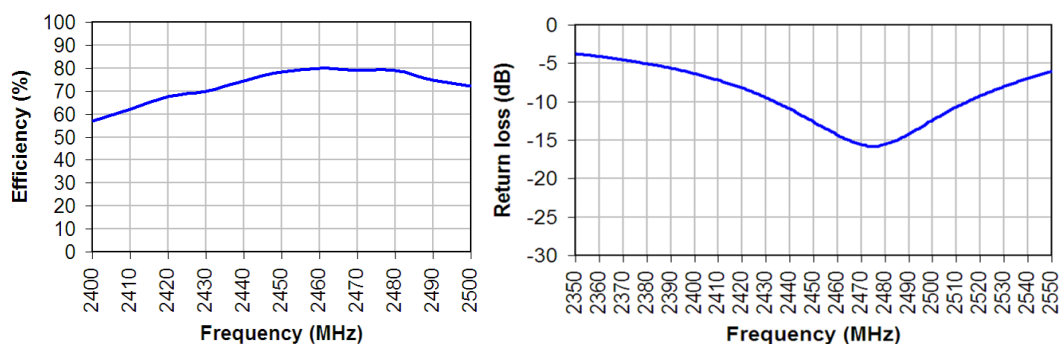

#### Antenna Radiation Patterns

#### 2.4 GHz Band

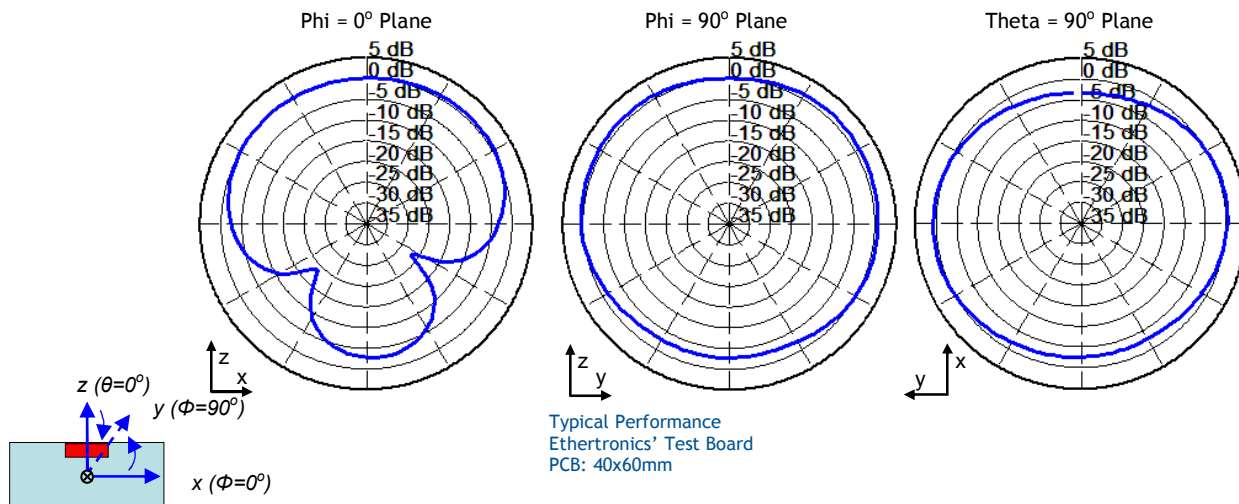

## Antenna Application Note

To optimize designs using Ethertronics' Savvi™ Bluetooth® single band antenna, the PCB should use the recommended land pattern shown in the Figures below. The land patterns are composed of a 50 ohm line connected to each antenna feed point. Ground clearance around and under the antenna, as shown in the PCB layout below, is recommended in order to maximize the antenna's performance. The antenna should be located along an edge of the PCB.

### Antenna Pad Layout

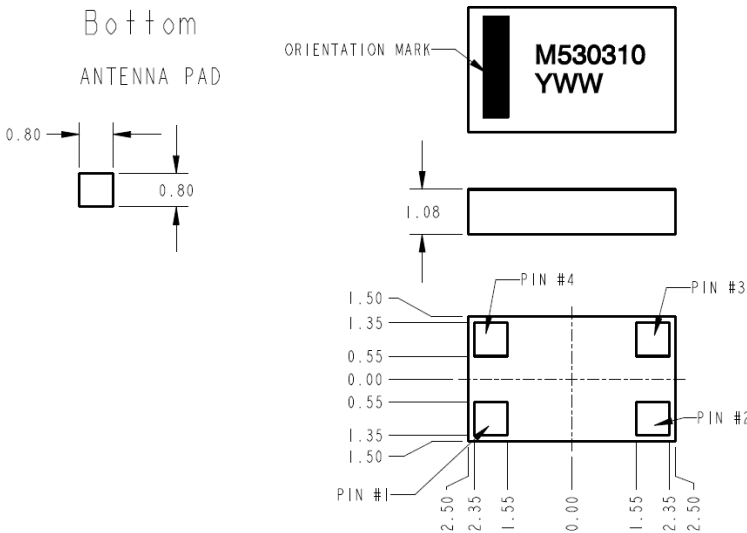

Pin	Description
1	Ground
2	Ground
3	Dummy Pad
4	Ground/BT Feed*

\*See page 20 for information on why the ground and feed line appear to be tied together.

### PCB Layout

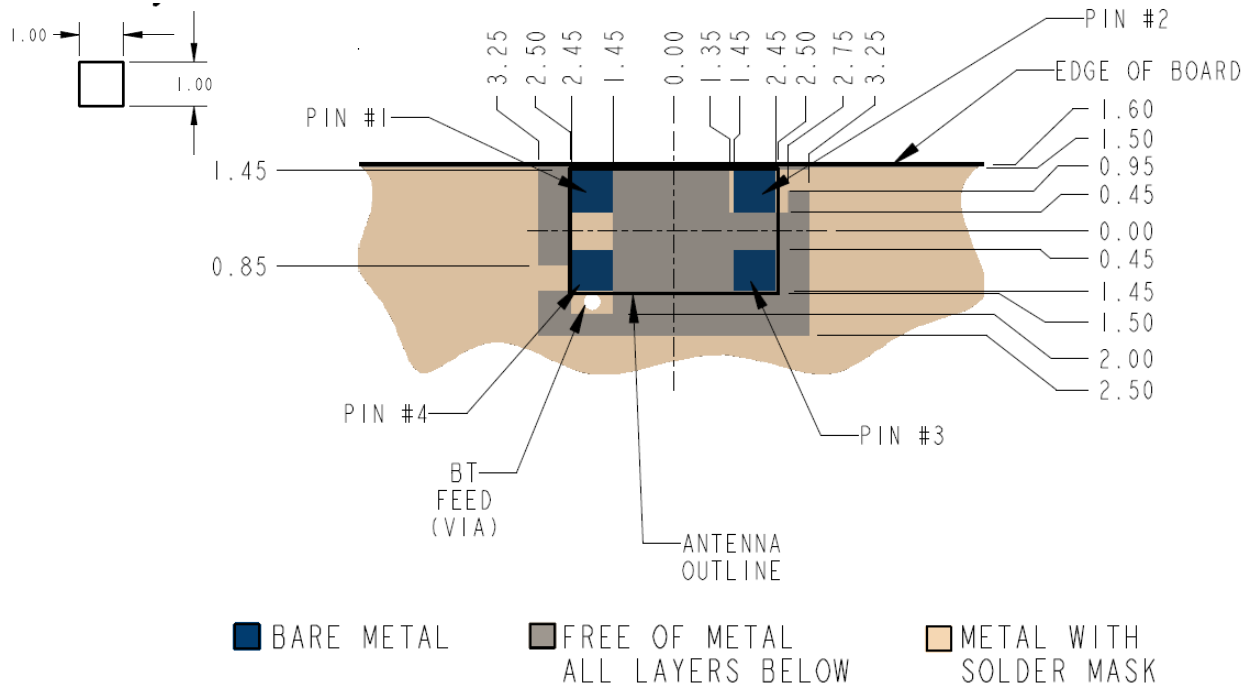

Ethertronics provides antenna layout files in .DXF format. This is a universal file format and should be converted into your specific file format

# Antenna Application Note

## Appendix 9 Summary of Savvi™ 4x2mm Bluetooth® Ceramic Antenna Part No. M420310

### Electrical Specifications

Typical Characteristics

BT Antenna	2.4–2.5 GHz
Peak Gain	0.3 dBi
Average Efficiency	57%
VSWR Match	3:1 max
Feed Point Impedance	50 Ω unbalanced
Power Handling	0.5 Watt cw
Polarization	Linear

### Mechanical Specifications

Size	4.00x2.00x1.08mm
Mounting	Surface mount
Packaging	Tape & Reel

### Typical Efficiency, Return Loss

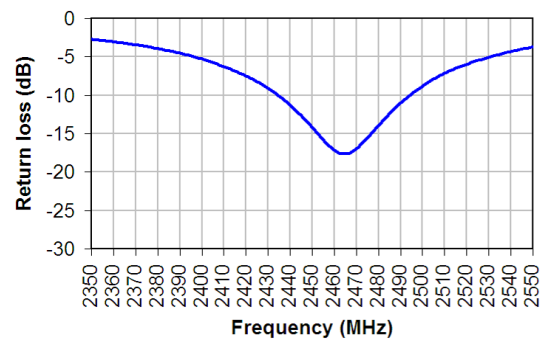
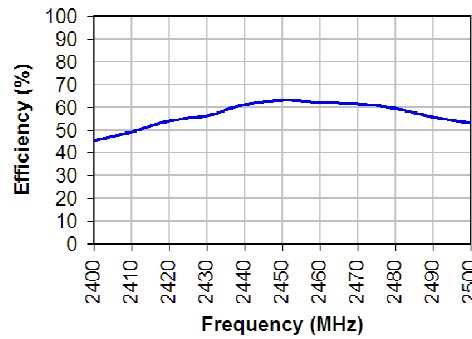

### Antenna Radiation Patterns

#### 2.4 GHz Band

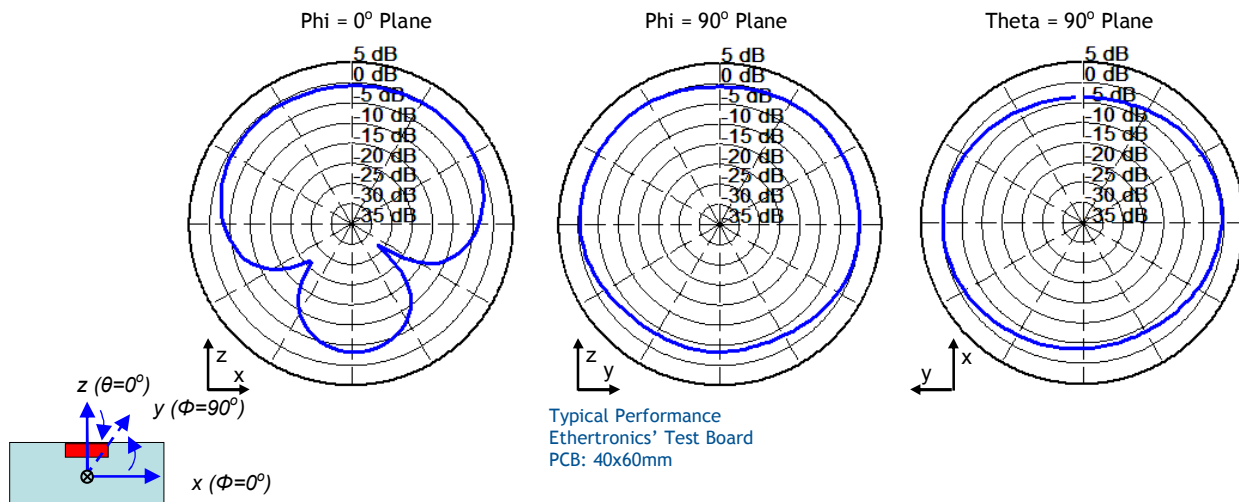

## Antenna Application Note

To optimize designs using Ethertronics' Savvi™ Bluetooth® single band antenna, the PCB should use the recommended land pattern shown in the Figures below. The land patterns are composed of a 50 ohm line connected to each antenna feed point. Ground clearance around and under the antenna, as shown in the PCB layout below, is recommended in order to maximize the antenna's performance. The antenna should be located along an edge of the PCB. The recommended default matching component value is 100pF.

### Antenna Pad Layout

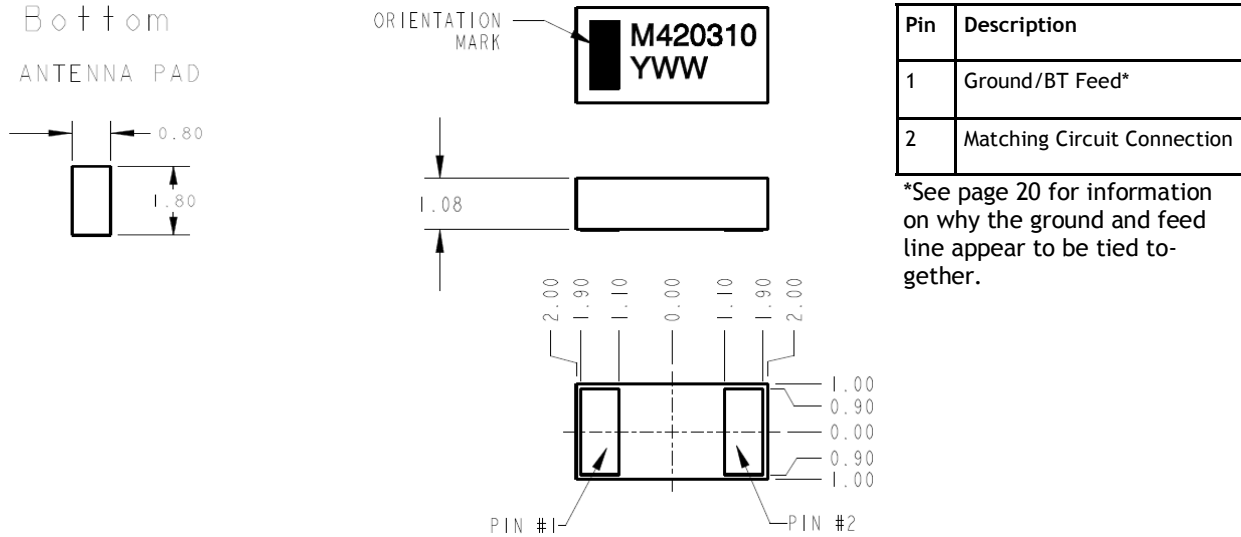

### PCB Layout

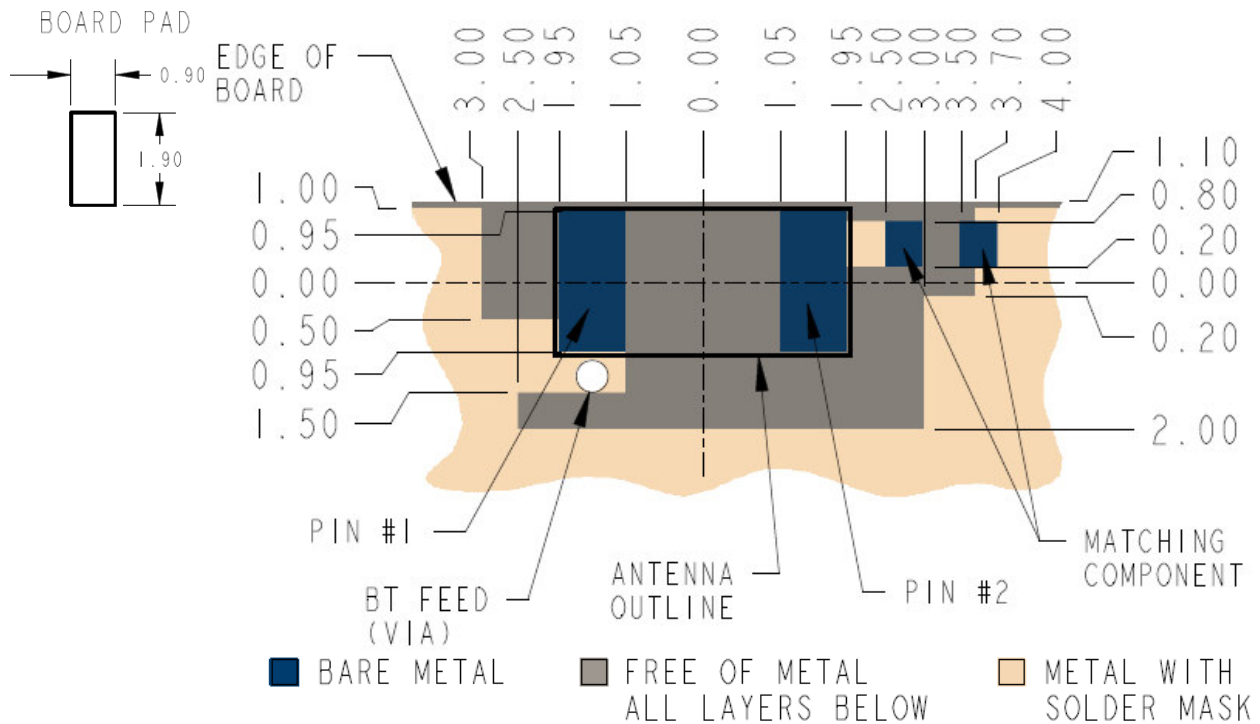

Ethertronics provides antenna layout files in .DXF format. This is a universal file format and should be converted into your specific file format

# Antenna Application Note

## Appendix 10 Summary of Savvi™ 4x2mm Bluetooth® Ceramic Antenna Part No. M420370

### Electrical Specifications

Typical Characteristics

BT Antenna	2.4–2.5 GHz
Peak Gain	1.6 dBi
Average Efficiency	60%
VSWR Match	1.4:1 max
Feed Point Impedance	50 Ω unbalanced
Power Handling	0.5 Watt cw
Polarization	Linear

### Mechanical Specifications

Size	4.00x2.00x.96mm
Mounting	Surface mount
Packaging	Tape & Reel

### Typical Efficiency, Return Loss

The M420370 antenna requires a matching circuit for proper use in the 2.4 GHz band. Please contact Ethertronics for details.

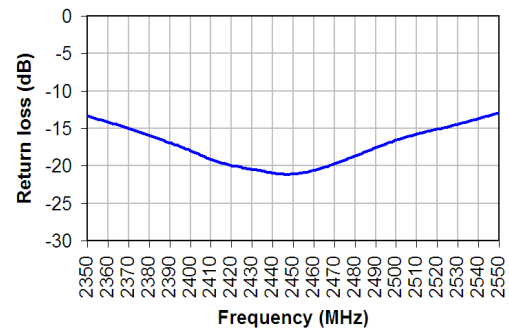
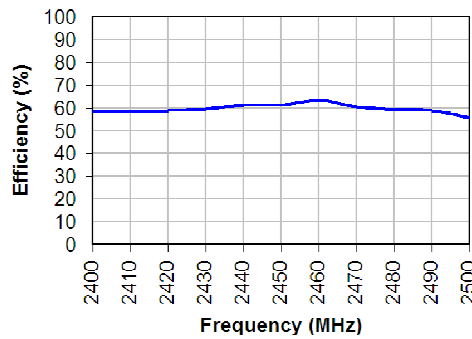

### Antenna Radiation Patterns

#### 2.4 GHz Band

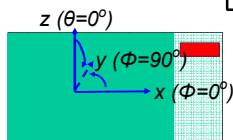
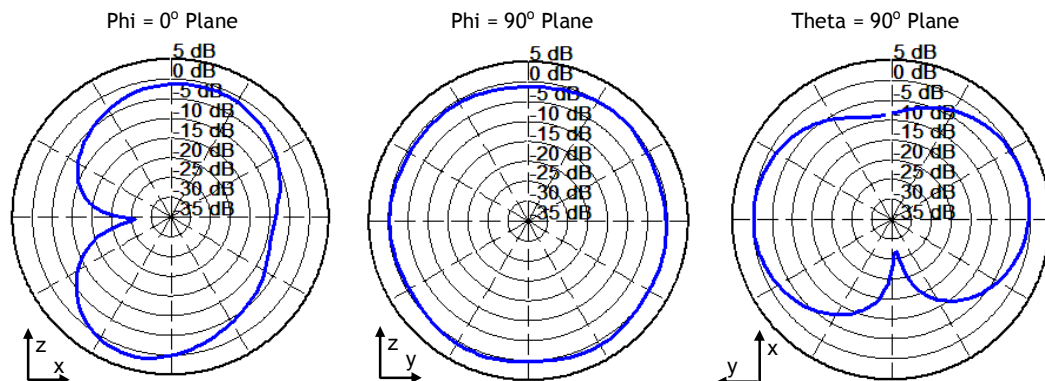

Typical Performance  
Ethertronics' Test Board  
PCB: 20x50mm



## Antenna Application Note

### Appendix 11

### Summary of Savvi™ 3x1.5mm Bluetooth®/WiMAX/ZigBee Ceramic Antenna Part No. M310310

#### Electrical Specifications

Typical Characteristics

(WiMAX 2.5–2.7 GHz capable with tuning. See Frequency Tuning Guidelines in Section 3.5).

BT Antenna	2.4–2.5 GHz
Peak Gain	1.27 dBi
Average Efficiency	72%
VSWR Match	2.3:1 max
Feed Point Impedance	50 Ω unbalanced
Power Handling	0.5 Watt cw
Polarization	Linear

#### Mechanical Specifications

Size	3.00x1.50x1.08mm
Mounting	Surface mount
Packaging	Tape & Reel

#### Typical Efficiency, Return Loss

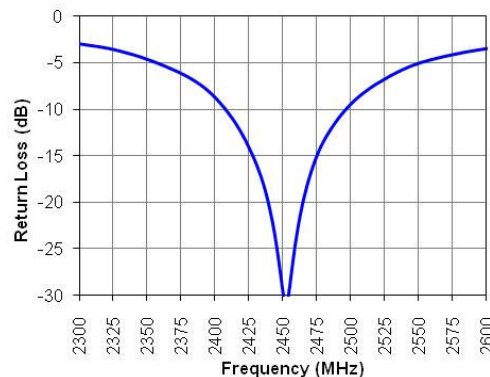
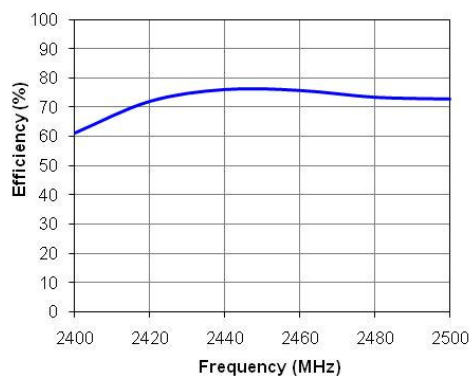

#### Antenna Radiation Patterns

#### 2.4 GHz Band

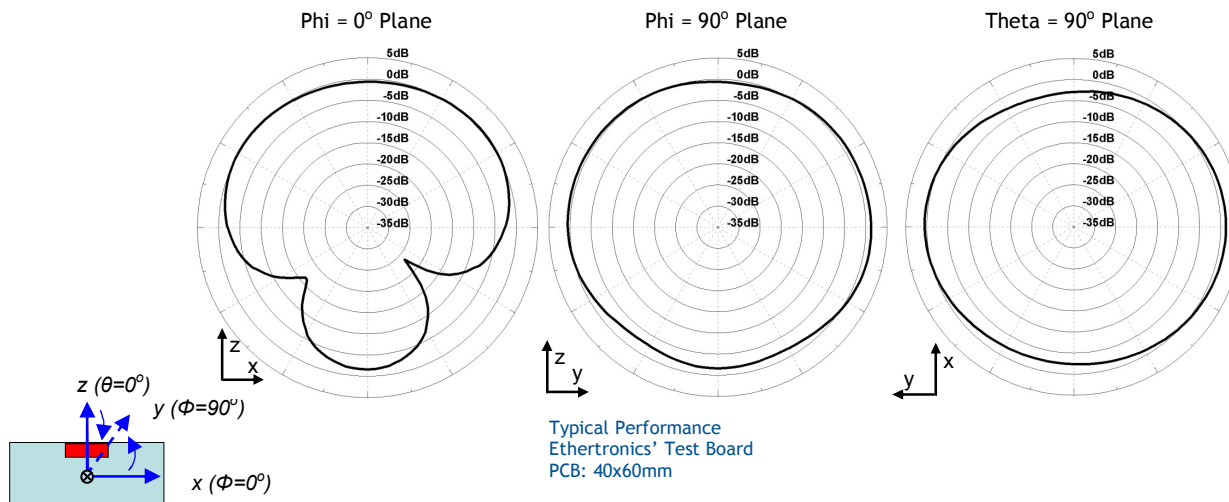

## Antenna Application Note

To optimize designs using Ethertronics' Savvi™ Bluetooth® /WiMAX single band antenna, the PCB should use the recommended land pattern shown in the Figures below. The land patterns are composed of a 50 ohm line connected to each antenna feed point. Ground clearance under the antenna, as shown in the PCB layout below, is recommended in order to maximize the antenna's performance. The antenna should be located along an edge of the PCB.

\*Note: Please see Tuning Guidelines (page 14) for more information on the matching circuit.

### Antenna Pad Layout

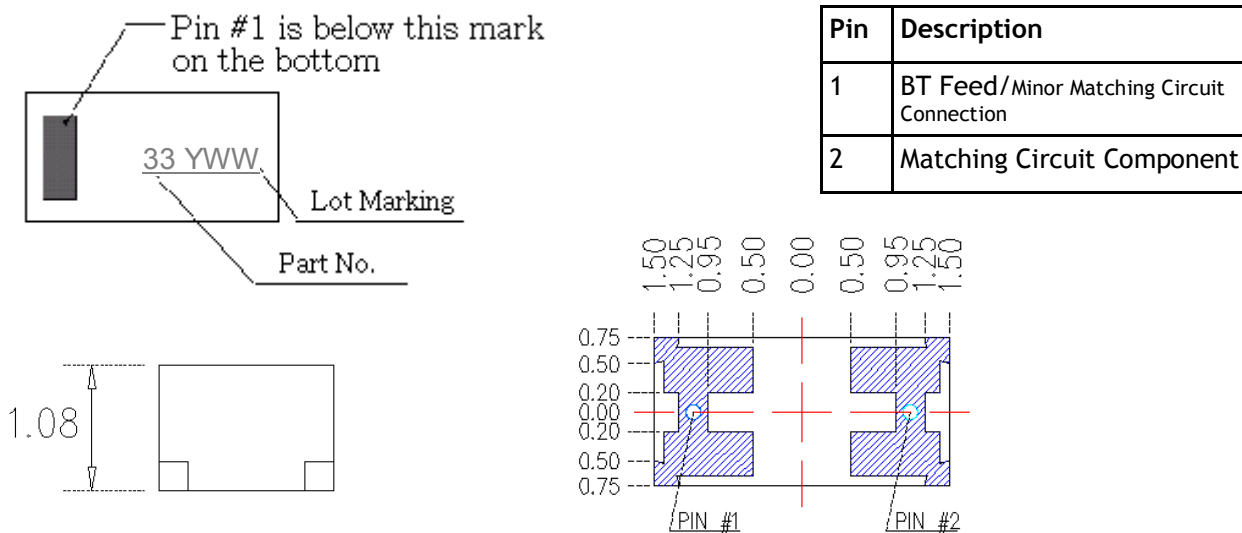

### PCB Layout

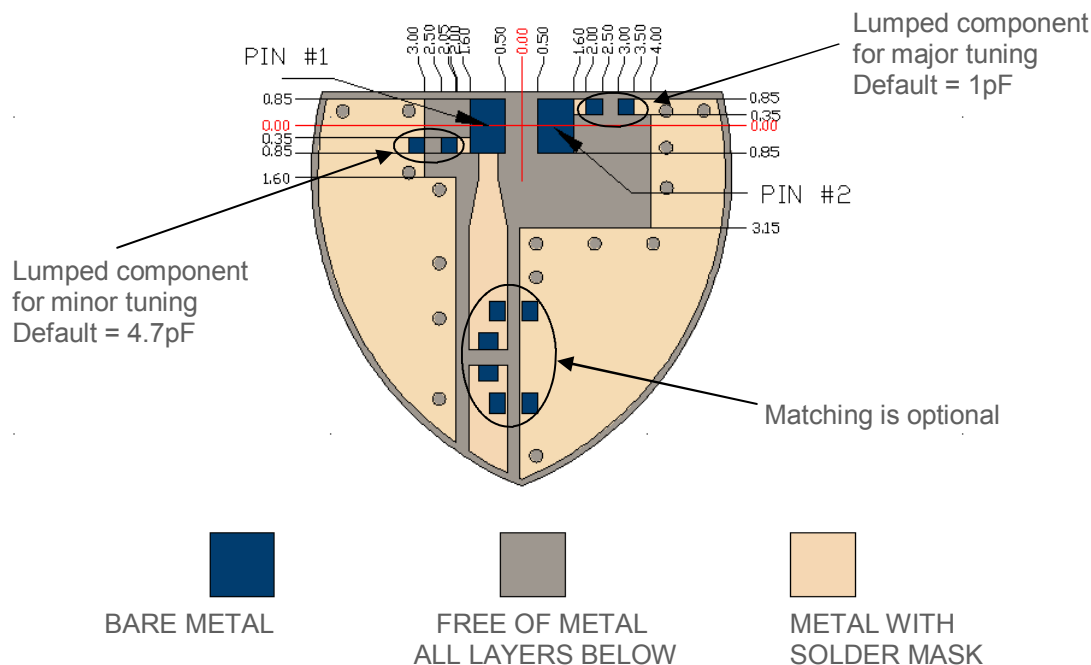

Ethertronics provides antenna layout files in .DXF format. This is a universal file format and should be converted into your specific file format

## Antenna Application Note

### Appendix 12

### Summary of Savvi™ 2x1.2mm Bluetooth®/WiMAX/ZigBee Ceramic Antenna Part No. M210310

#### Electrical Specifications

Typical Characteristics

(WiMAX 2.5–2.7 GHz capable with tuning. See Tuning Guidelines in Section 3.5).

BT Antenna	2.4–2.5 GHz
Peak Gain	1.4 dBi
Average Efficiency	69%
VSWR Match	2.0:1 max
Feed Point Impedance	50 Ω unbalanced
Power Handling	0.5 Watt cw
Polarization	Linear

#### Mechanical Specifications

Size	2.00x1.20x1.08mm
Mounting	Surface mount
Packaging	Tape & Reel

#### Typical Efficiency, Return Loss

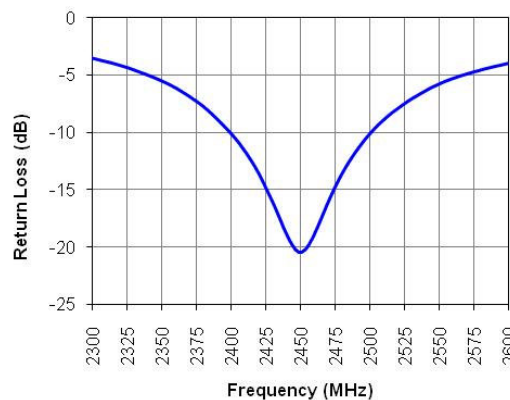
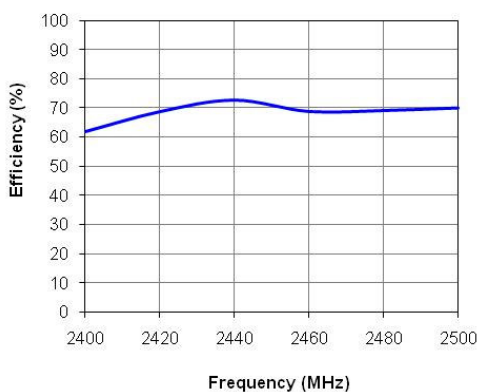

#### Antenna Radiation Patterns

#### 2.4 GHz Band

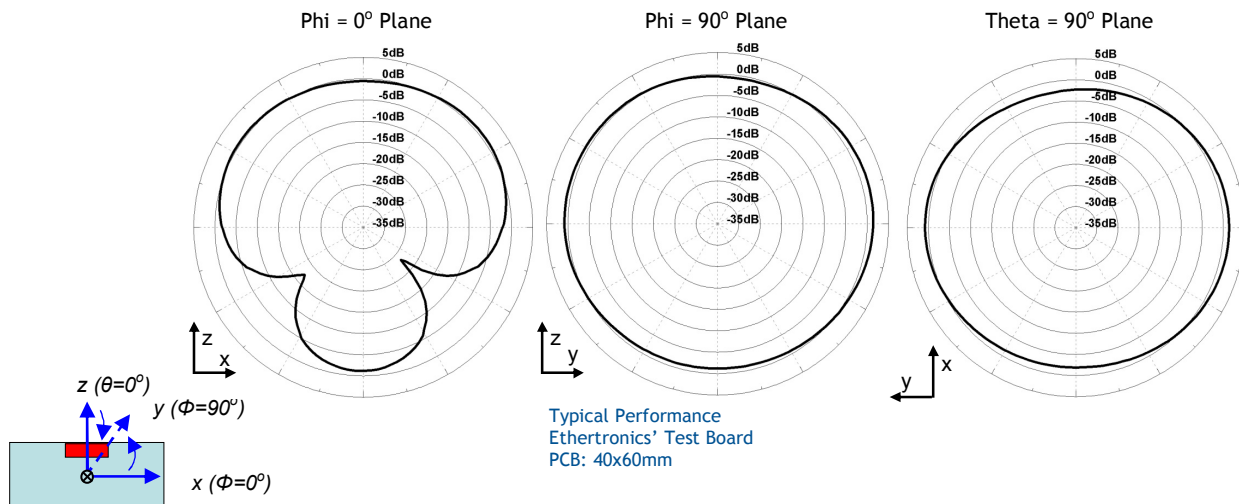

## Antenna Application Note

To optimize designs using Ethertronics' Savvi™ Bluetooth®/WiMAX single band antenna, the PCB should use the recommended land pattern shown in the Figures below. The land patterns are composed of a 50 ohm line connected to each antenna feed point. Ground clearance under the antenna, as shown in the PCB layout below, is recommended in order to maximize the antenna's performance. The antenna should be located along an edge of the PCB.

\*Note: Please see Tuning Guidelines (page 14) for more information on the matching circuit.

### Antenna Pad Layout

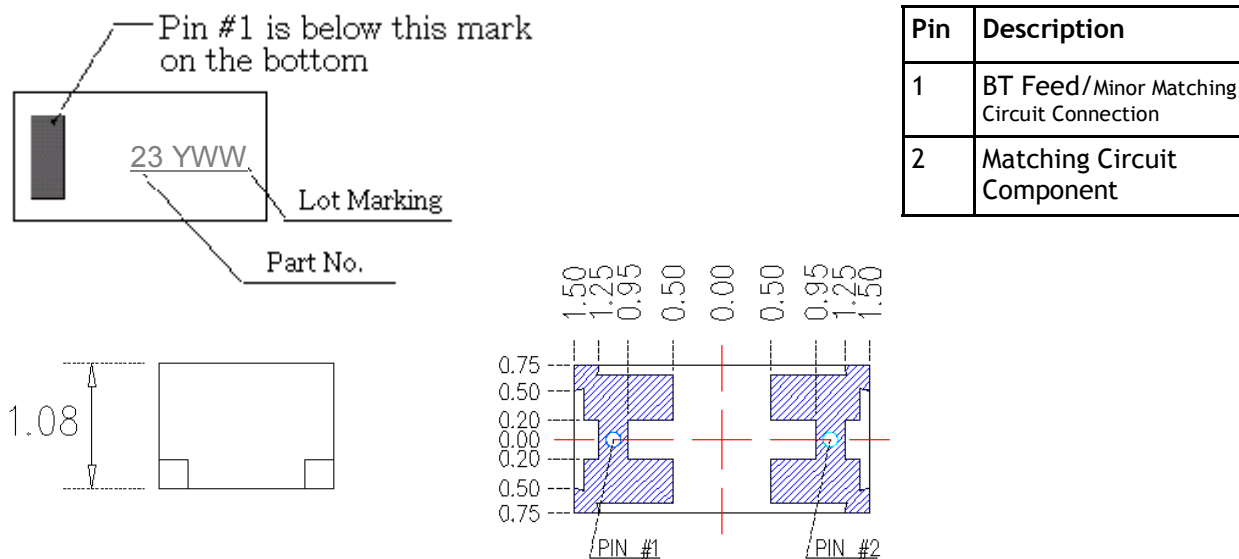

### PCB Layout

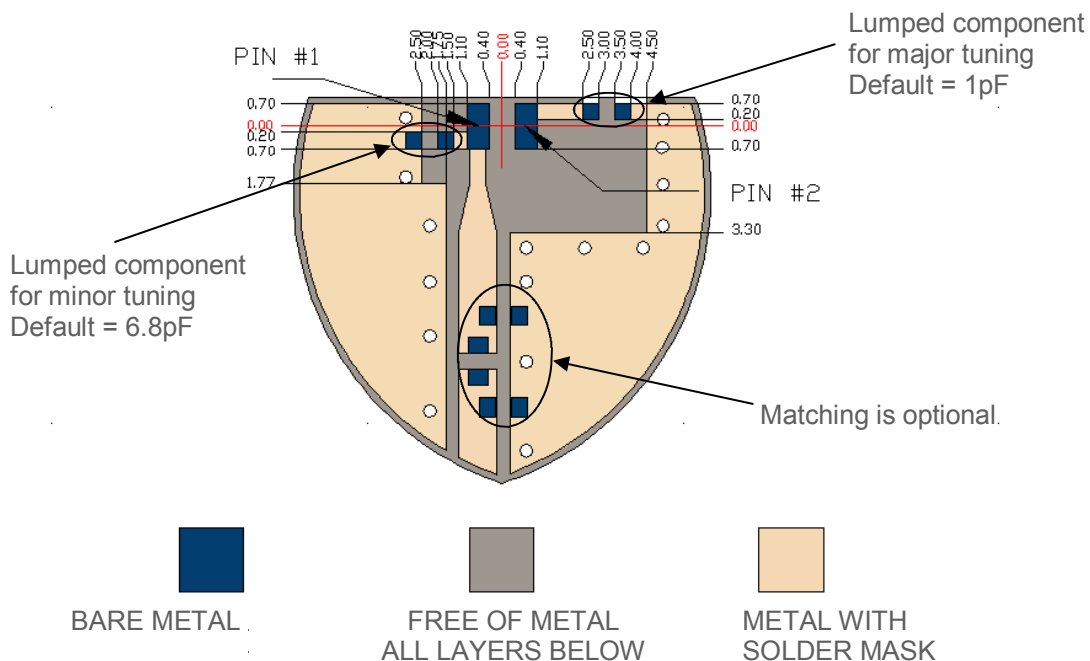

Ethertronics provides antenna layout files in .DXF format. This is a universal file format and should be converted into your specific file format

# Antenna Application Note

## Appendix 13 Summary of Savvi™ 8x3mm WLAN Ceramic Antenna Part No. M830510

### Electrical Specifications Typical Characteristics

WLAN a/b/g/n Antenna	2.4–2.5 GHz (b/g/n)	4.9–5.8 GHz (a/n)
Peak Gain	1.1 dBi	3.2 dBi
Average Efficiency	54%	69%
VSWR Match	2.6:1 max	3.0:1 max
Feed Point Impedance	50 Ω unbalanced	

### Mechanical Specifications

Size	8.00x3.00x1.33mm
Mounting	Surface mount
Packaging	Tape & Reel

### Typical Efficiency, Return Loss

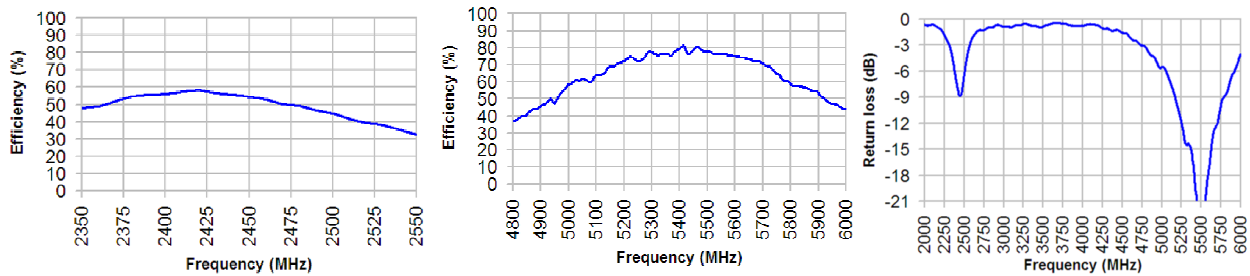

### Antenna Radiation Patterns

Typical Performance  
Ethertronics' Test Board  
PCB: 40x80mm

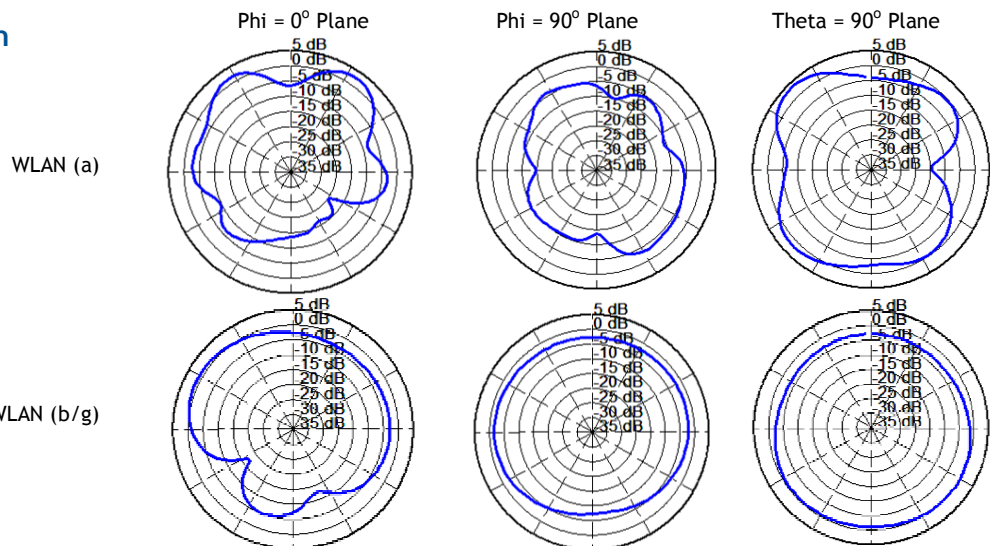
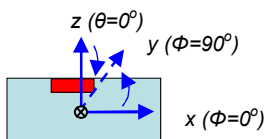

## Antenna Application Note

To optimize product designs using Ethertronics Savvi™ WLAN antennas, the PCB should use the recommended land pattern shown in the Figures below. The land patterns are composed of a 50 ohm line connected to each antenna feed point. Ground clearance around and under the antenna, as shown in the PCB layout below, is recommended in order to maximize the antenna's performance. The antenna should be located along an edge of the PCB.

### Antenna Pad Layout

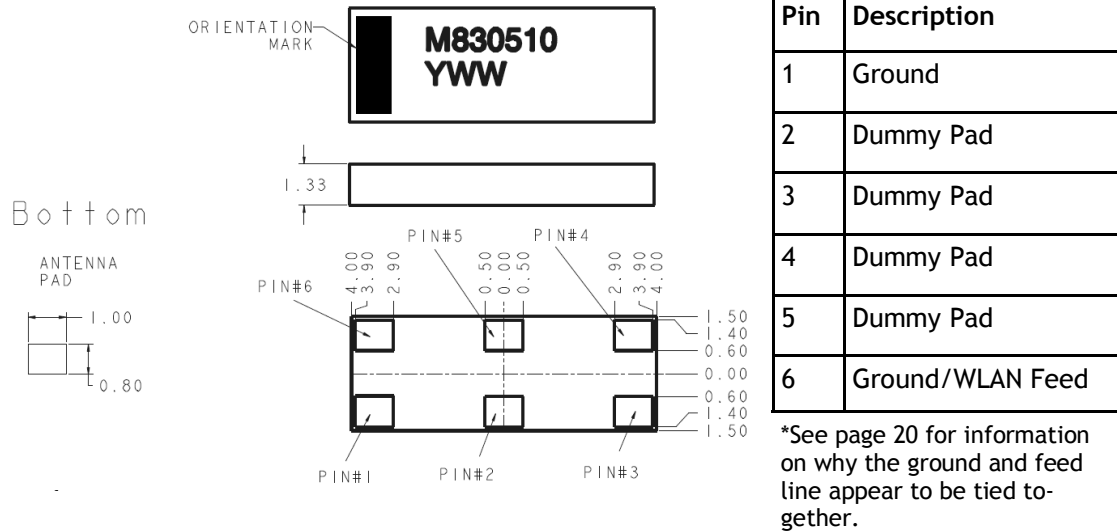

### PCB Layout

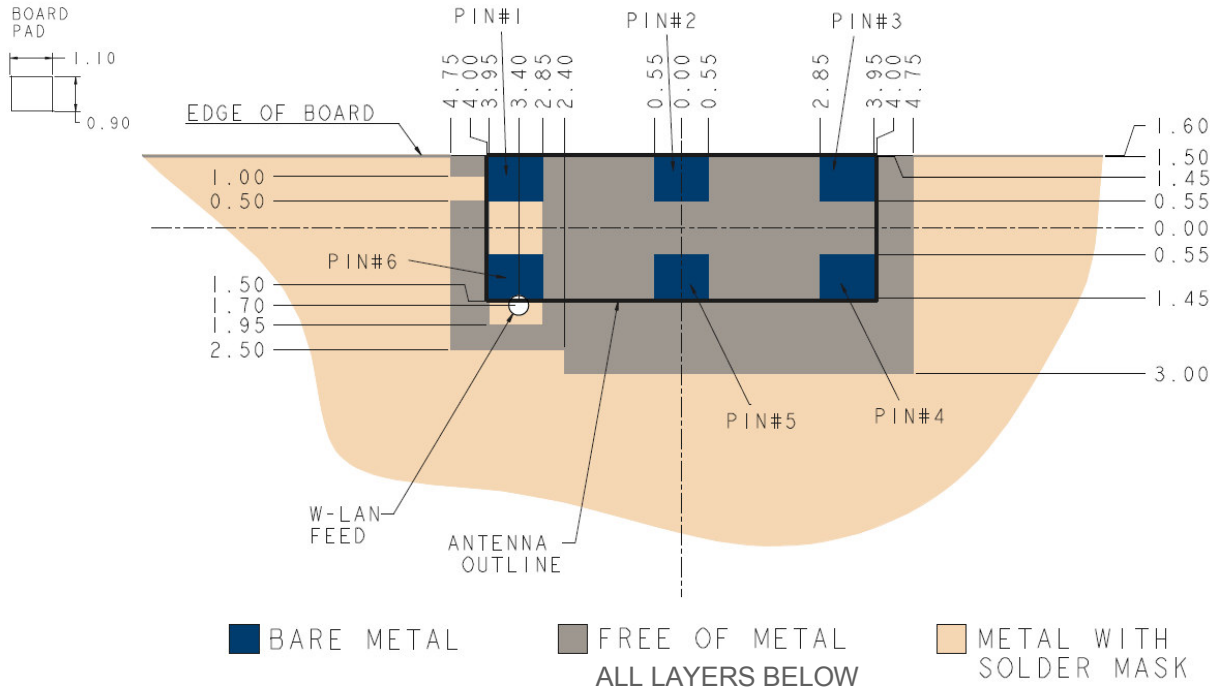

Ethertronics provides antenna layout files in .DXF format. This is a universal file format and should be converted into your specific file format

## Antenna Application Note

### Appendix 14

### Summary of Savvi™ 3x1.5mm WiMAX Ceramic Antenna 3 GHz Part No. M310410

#### Electrical Specifications

Typical Characteristics

WiMAX Antenna	3.4–3.6 GHz
Peak Gain	3.56 dBi
Average Efficiency	76%
VSWR Match	2.3:1 max
Feed Point Impedance	50 Ω unbalanced

#### Mechanical Specifications

Size	3.00x1.50x1.08mm
Mounting	Surface mount
Packaging	Tape & Reel

#### Typical Efficiency, Return Loss

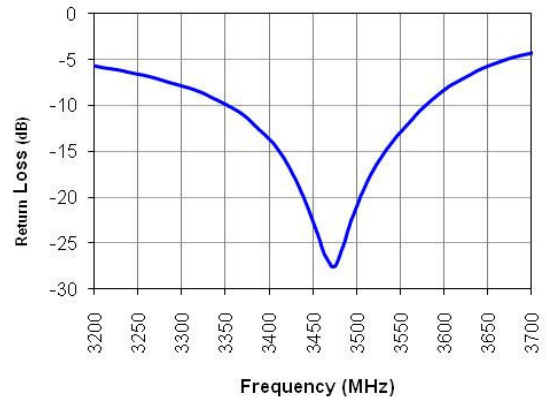
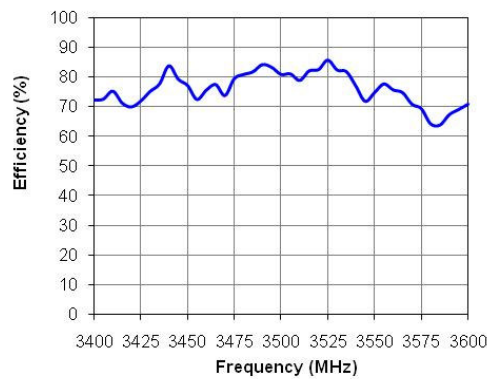

#### Antenna Radiation Patterns

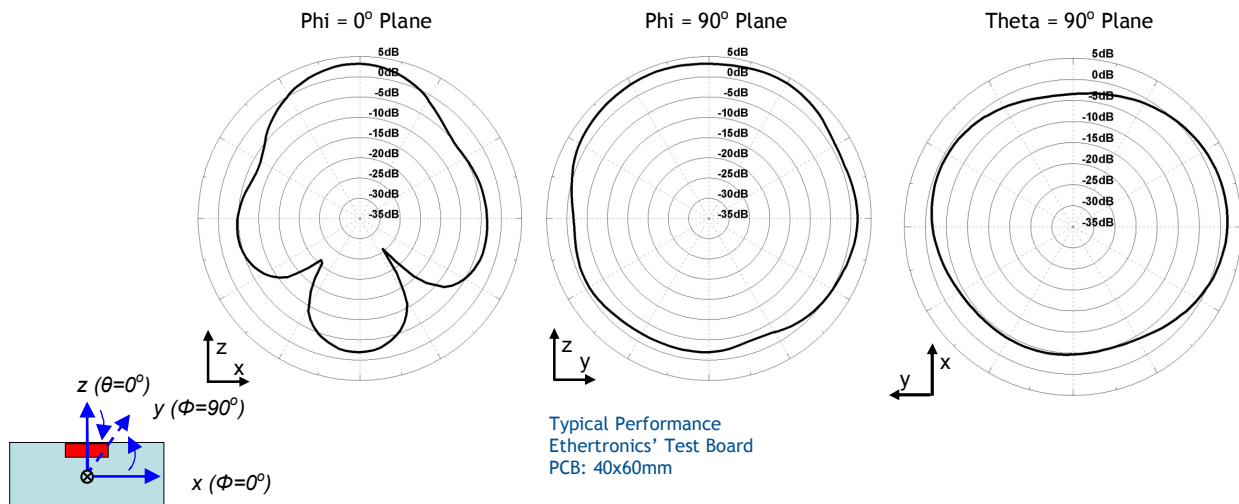

## Antenna Application Note

To optimize designs using Ethertronics' Savvi™ WiMAX single band antenna, the PCB should use the recommended land pattern shown in the Figures below. The land patterns are composed of a 50 ohm line connected to each antenna feed point. Ground clearance under the antenna, as shown in the PCB layout below, is recommended in order to maximize the antenna's performance. The antenna should be located along an edge of the PCB.

\*Note: Please see Tuning Guidelines (page 14) for more information on the matching circuit.

### Antenna Pad Layout

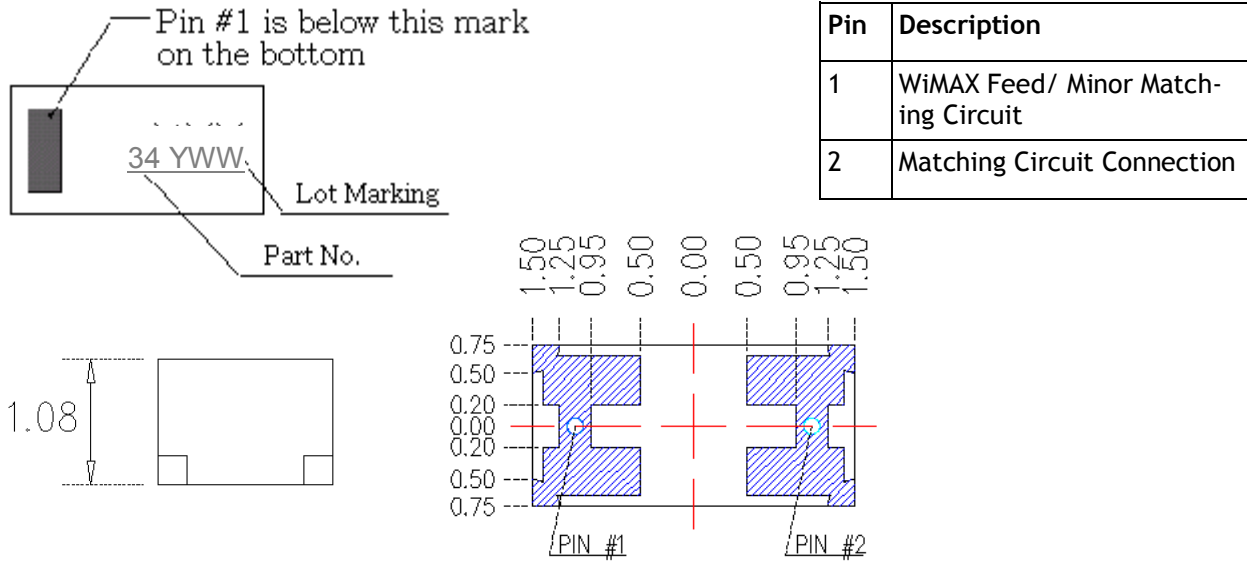

### PCB Layout

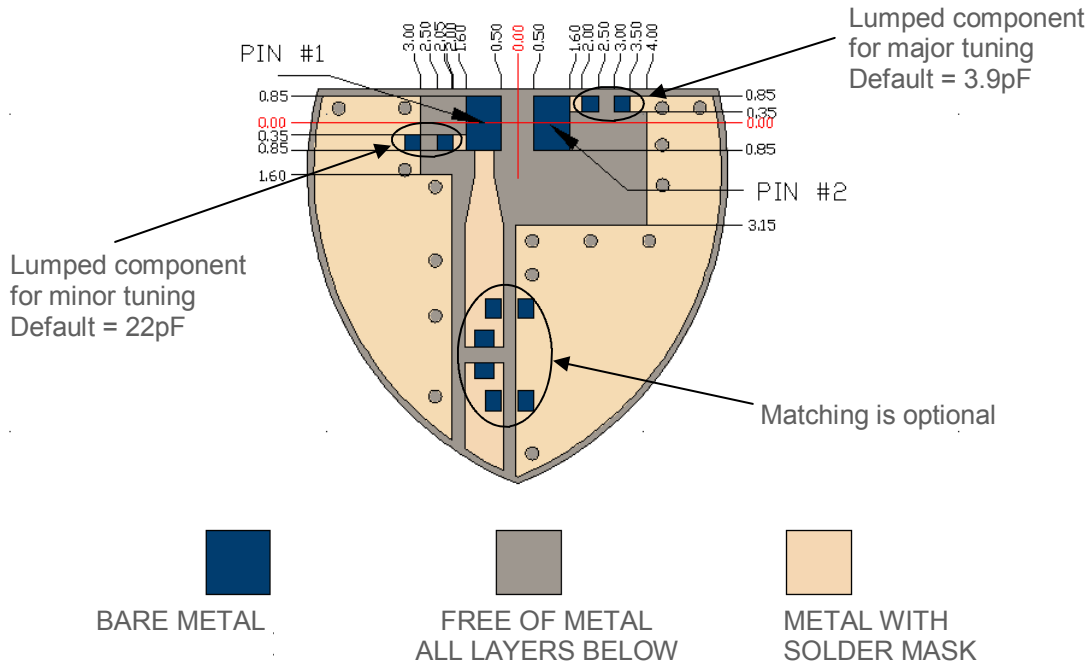

Ethertronics provides antenna layout files in .DXF format. This is a universal file format and should be converted into your specific file format

# Antenna Application Note

## Appendix 15

### Summary of Savvi™ 2x1.2mm WiMAX Ceramic Antenna 3 GHz Part No. M210410

#### Electrical Specifications

Typical Characteristics

WiMAX Antenna	3.4–3.6 GHz
Peak Gain	3.88 dBi
Average Efficiency	74%
VSWR Match	2.5:1 max
Feed Point Impedance	50 Ω unbalanced

#### Mechanical Specifications

Size	2.00x1.20x1.08mm
Mounting	Surface mount
Packaging	Tape & Reel

#### Typical Efficiency, Return Loss

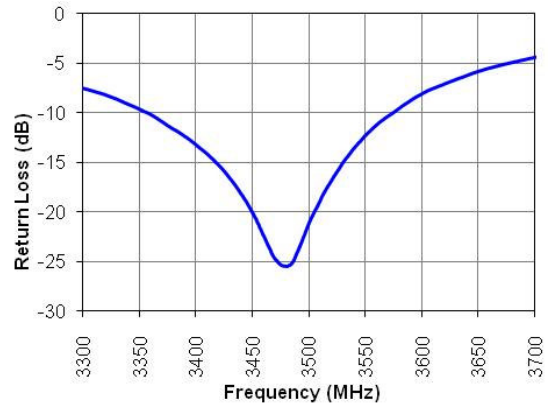
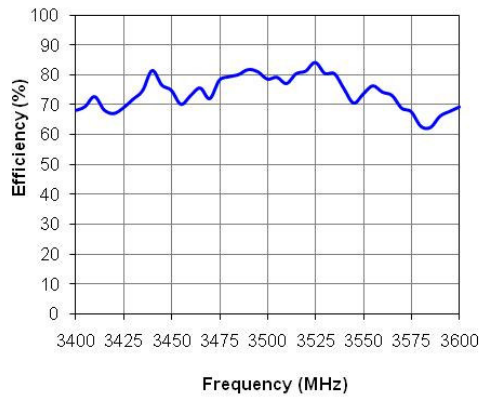

#### Antenna Radiation Patterns

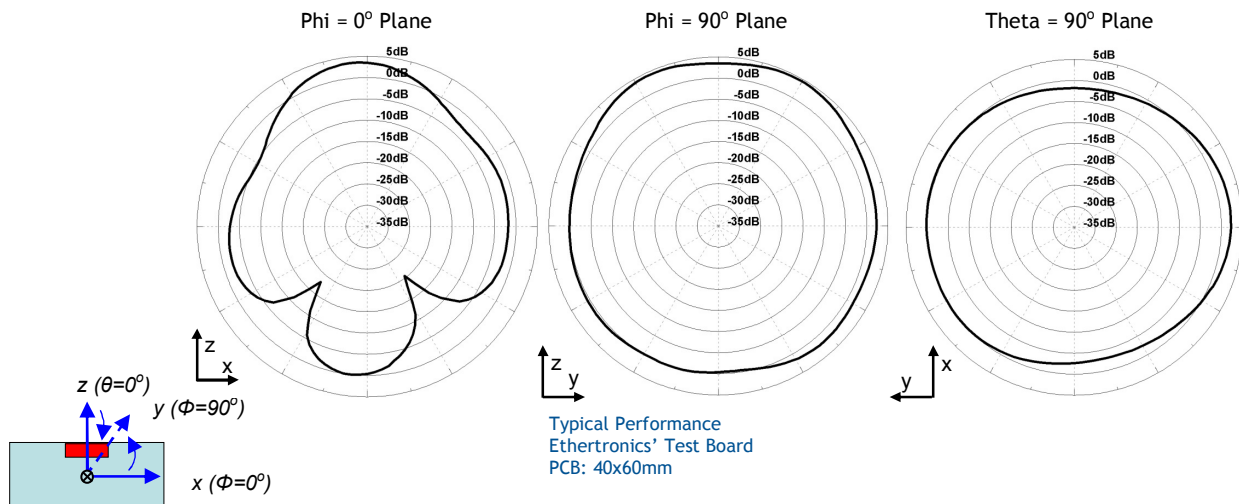

## Antenna Application Note

To optimize designs using Ethertronics' Savvi™ WiMAX single band antenna, the PCB should use the recommended land pattern shown in the Figures below. The land patterns are composed of a 50 ohm line connected to each antenna feed point. Ground clearance under the antenna, as shown in the PCB layout below, is recommended in order to maximize the antenna's performance. The antenna should be located along an edge of the PCB.

\*Note: Please see Tuning Guidelines (page 14) for more information on the matching circuit.

### Antenna Pad Layout

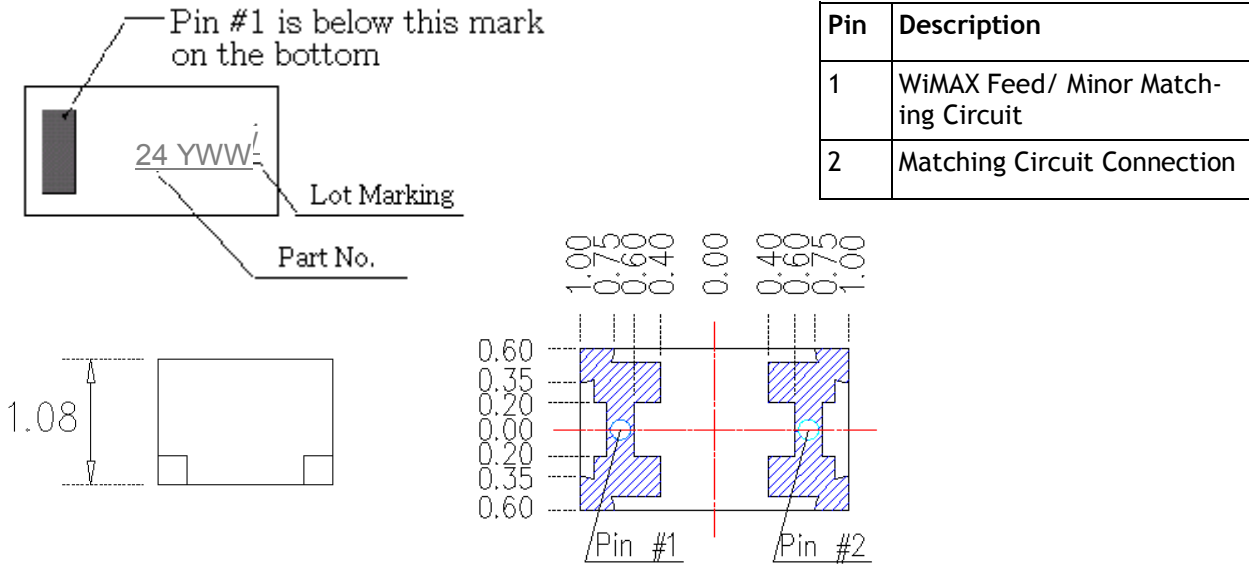

### PCB Layout

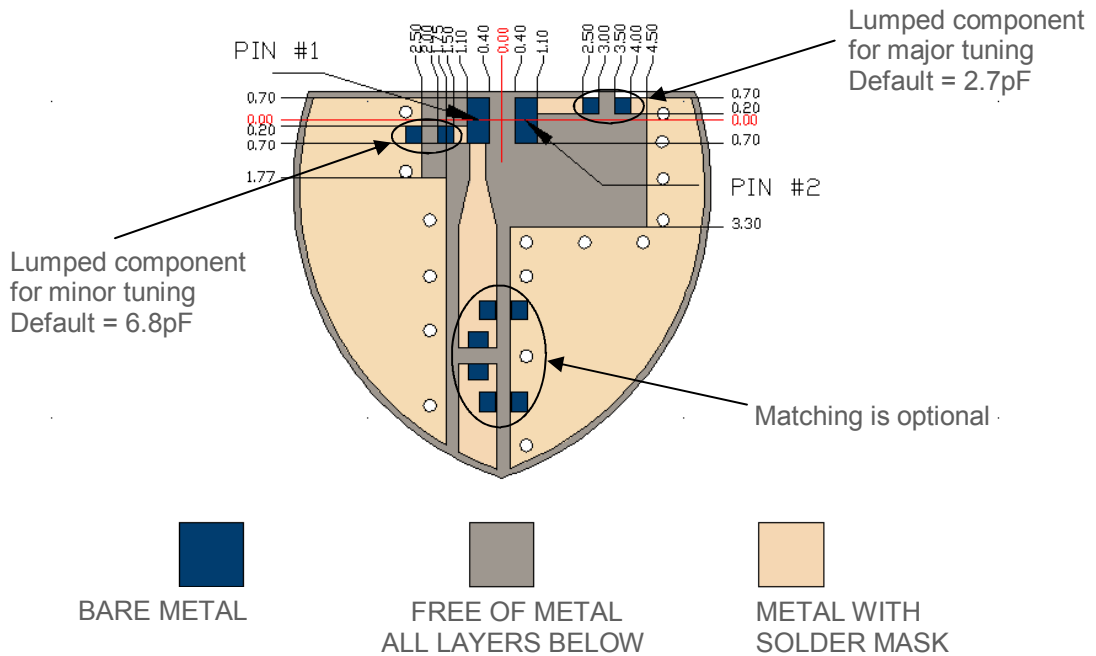

Ethertronics provides antenna layout files in .DXF format. This is a universal file format and should be converted into your specific file format

## Antenna Application Note

### Appendix 16 Summary of Savvi™ 14x4mm GPS/Bluetooth® Ceramic Antenna Part No. M442100

#### Electrical Specifications

Typical Characteristics

GPS/BT Antenna	1.575 GHz	2.4 -2.5 GHz
Peak Gain	2.90 dBi	1.08 dBi
Average Efficiency	70%	60%
VSWR Match	2.0:1 max	2.6:1 max
Feed Point Impedance	50 Ω unbalanced	50 Ω unbalanced
Power Handling	.5 Watt cw	.5 Watt cw
Polarization	Linear	Linear
Isolation	<-25 dB	<-20dB

#### Mechanical Specifications

Size	14x4x1.33mm
Mounting	Surface mount
Packaging	Tape & Reel

#### Typical Efficiency, Isolation & Return Loss

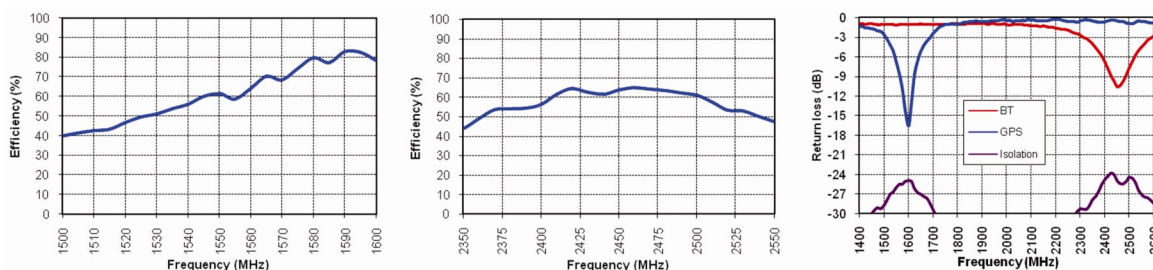

#### Antenna Radiation Patterns

1.575 GHz Band

2.4 GHz Band

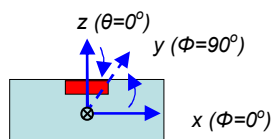

Phi = 0° Plane

Phi = 90° Plane

Theta = 90° Plane

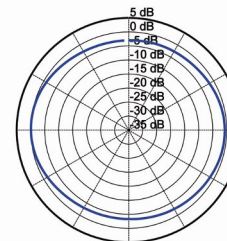
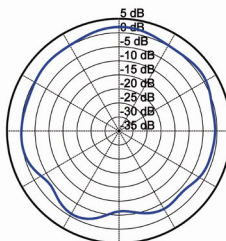
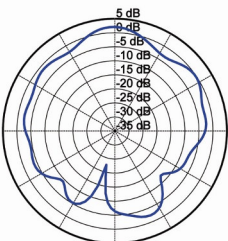
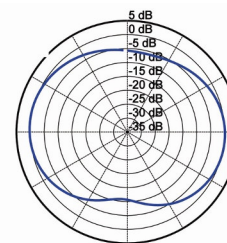
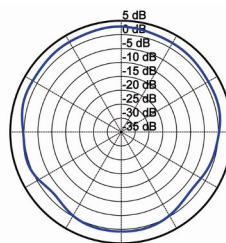
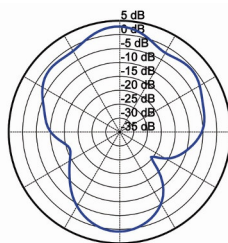

Typical Performance  
Ethertronics' Test Board  
PCB: 40x80mm

## Antenna Application Note

To optimize product designs using Ethertronics Savvi™ Bluetooth®/GPS antennas, the PCB should use the recommended land pattern shown in the Figures below. The land patterns are composed of a 50 ohm line connected to each antenna feed point. Ground clearance around and under the antenna, as shown in the PCB layout below, is recommended in order to maximize the antenna's performance. The antenna should be located along an edge of the PCB.

### Antenna Pad Layout

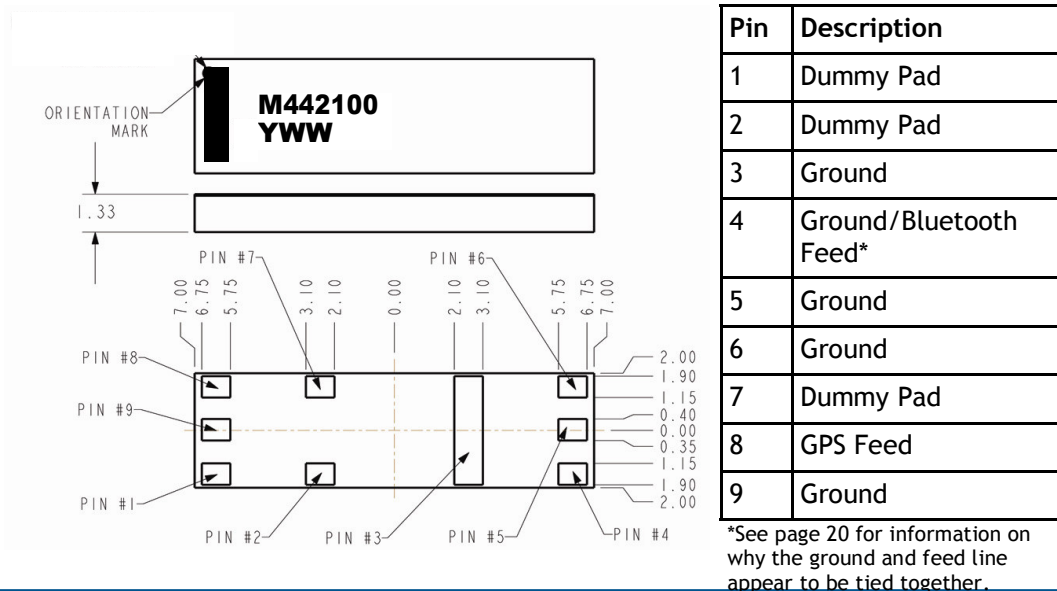

### PCB Layout

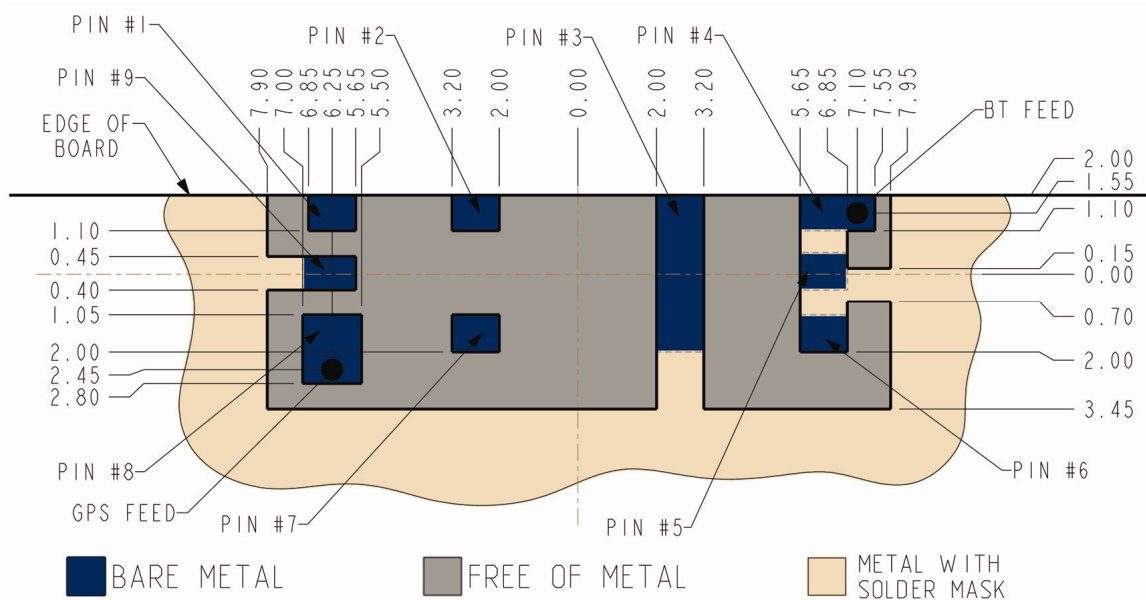

Ethertronics provides antenna layout files in .DXF format. This is a universal file format and should be converted into your specific file format

# Antenna Application Note

## Appendix 17 Summary of Savvi™ 12x3mm GPS/Bluetooth® Ceramic Antenna Part No. M232110

### Electrical Specifications

Typical Characteristics

GPS/BT Antenna	1.575 GHz	2.4–2.5 GHz
Peak Gain	1.98 dBi	1.88 dBi
Average Efficiency	62%	67%
VSWR Match	2.0:1 max	2.6:1 max
Feed Point Impedance	50 Ω unbalanced	50 Ω unbalanced
Power Handling	.5 Watt cw	.5 Watt cw
Polarization	Linear	Linear
Isolation	<-25 dB	<-20dB

### Mechanical Specifications

Size	12.0x3.0x1.33mm
Mounting	Surface mount
Packaging	Tape & Reel

### Typical Efficiency, Isolation & Return Loss

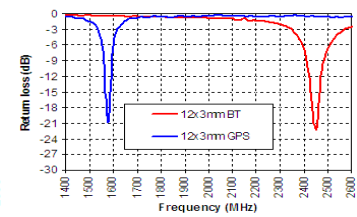
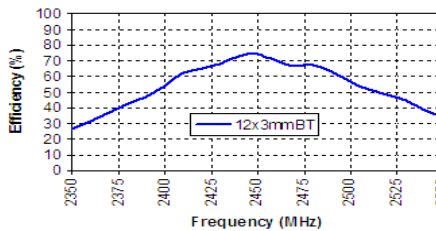
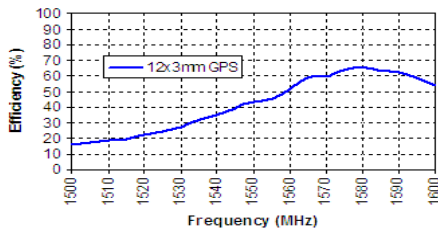

### Antenna Radiation Patterns

1.575 GHz Band

2.4 GHz Band

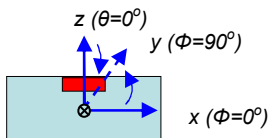

Phi = 0° Plane

Phi = 90° Plane

Theta = 90° Plane

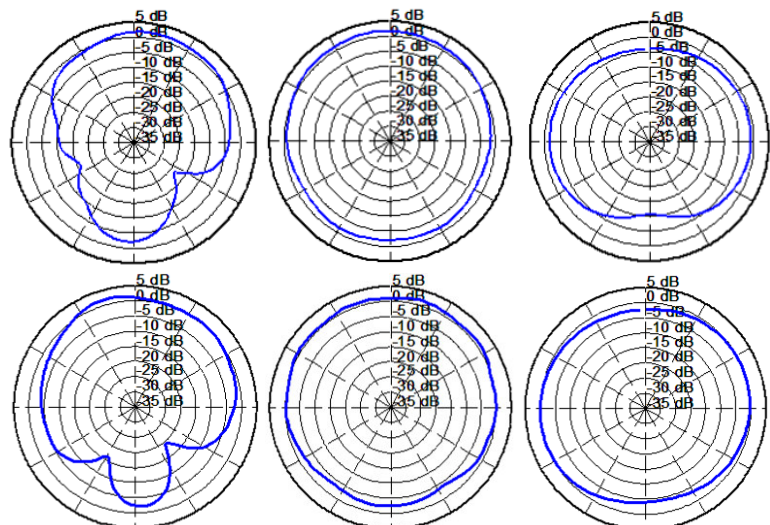

Typical Performance  
Ethertronics' Test Board  
PCB: 40x80mm

## Antenna Application Note

To optimize product designs using Ethertronics Savvi™ Bluetooth®/GPS antennas, the PCB should use the recommended land pattern shown in the Figures below. The land patterns are composed of a 50 ohm line connected to each antenna feed point. Ground clearance around and under the antenna, as shown in the PCB layout below, is recommended in order to maximize the antenna's performance. The antenna should be located along an edge of the PCB.

### Antenna Pad Layout

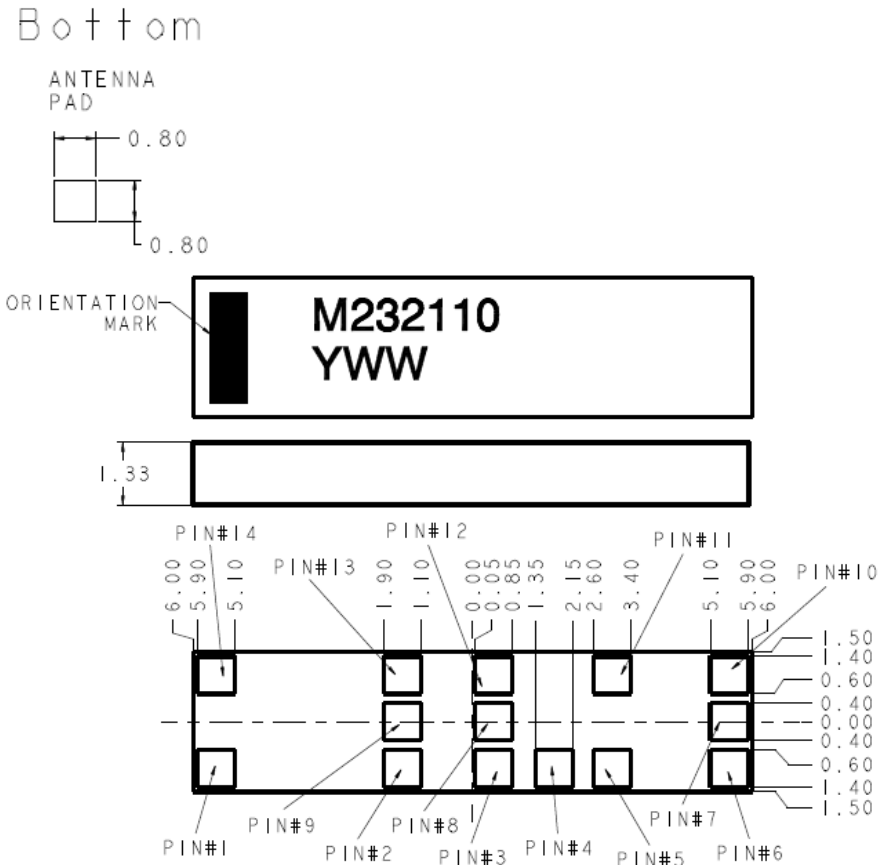

Pin	Description
1	Ground
2	Ground
3	Ground
4	Ground
5	Ground
6	Ground
7	Ground/BT Feed*
8	Ground
9	Ground
10	Ground
11	Ground
12	Ground
13	Ground/ GPS Feed*
14	Dummy Pad

\*See page 20 for information on why the ground and feed line appear to be tied together.

Ethertronics provides antenna layout files in .DXF format. This is a universal file format and should be converted into your specific file format

## Antenna Application Note

To optimize product designs using Ethertronics Savvi™ GPS Bluetooth® antennas, the PCB should use the recommended land pattern shown in the Figures below. The land patterns are composed of a 50 ohm line connected to each antenna feed point. Ground clearance around and under the antenna, as shown in the PCB layout below, is recommended in order to maximize the antenna's performance. The antenna should be located along an edge of the PCB.

### PCB Layout

### PCB Layout

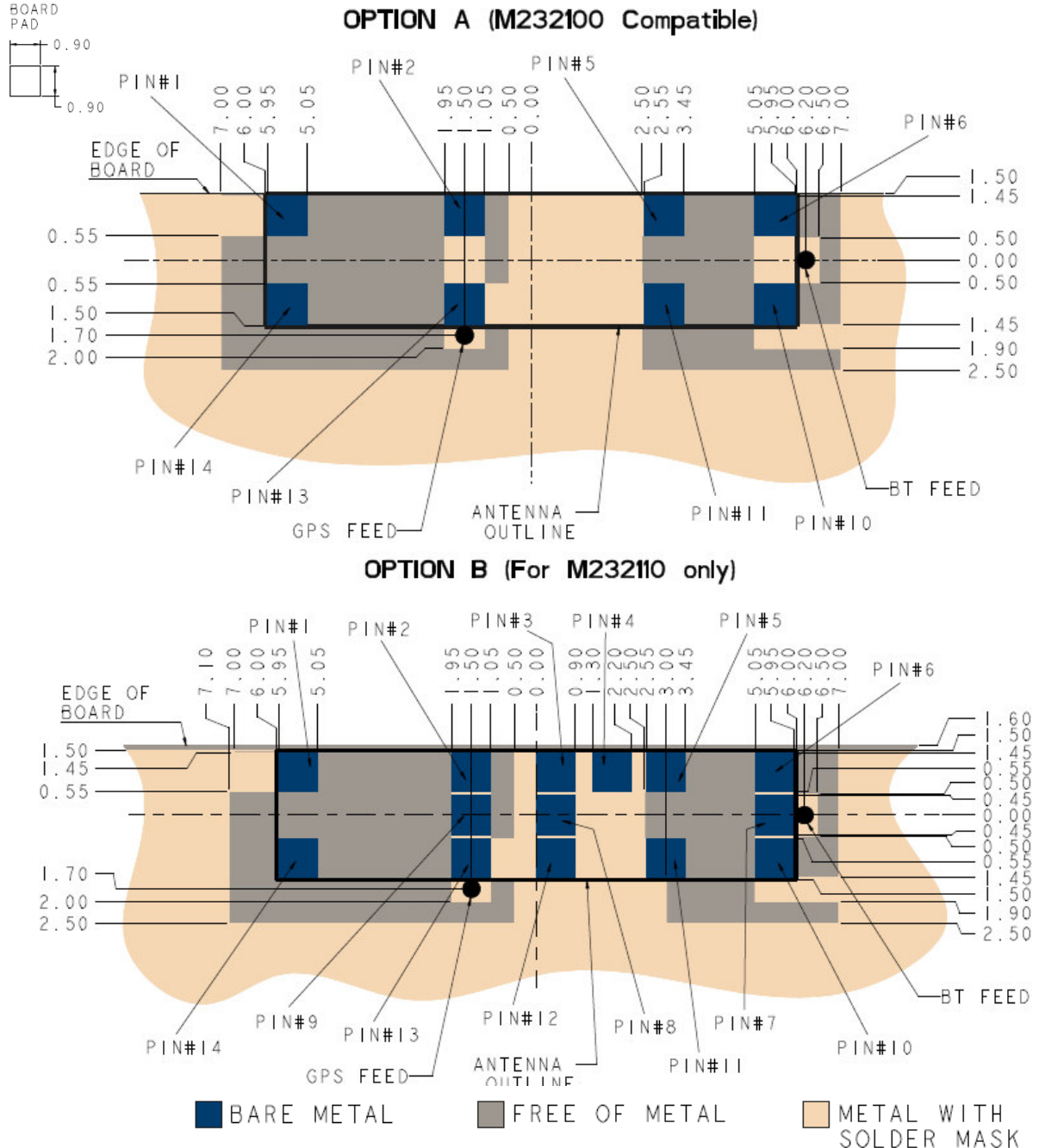

Ethertronics provides antenna layout files in .DXF format. This is a universal file format and should be converted into your specific file format

# Antenna Application Note

## Appendix 18 Summary of Savvi™ 10x3mm GPS/Bluetooth® Ceramic Antenna Part No. M032100

### Electrical Specifications

Typical Characteristics

GPS/BT Antenna	1.575 GHz	2.4 -2.5 GHz
Peak Gain	1.5 dBi	2.1 dBi
Average Efficiency	61%	58%
VSWR Match	1.7:1 max	2.5:1 max
Feed Point Impedance	50 Ω unbalanced	50 Ω unbalanced
Power Handling	.5 Watt cw	.5 Watt cw
Polarization	Linear	Linear
Isolation	<-25 dB	<-20dB

### Mechanical Specifications

Size	10x3x1.31mm
Mounting	Surface mount
Packaging	Tape & Reel

### Typical Efficiency, Isolation & Return Loss

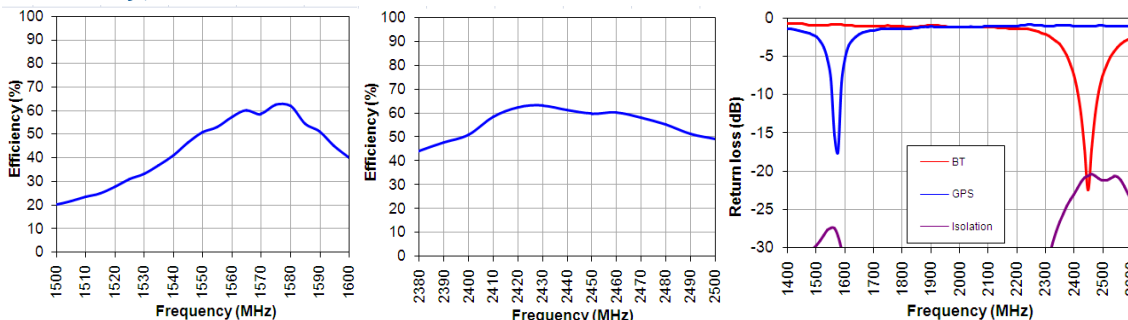

### Antenna Radiation Patterns

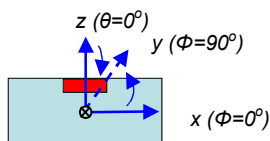
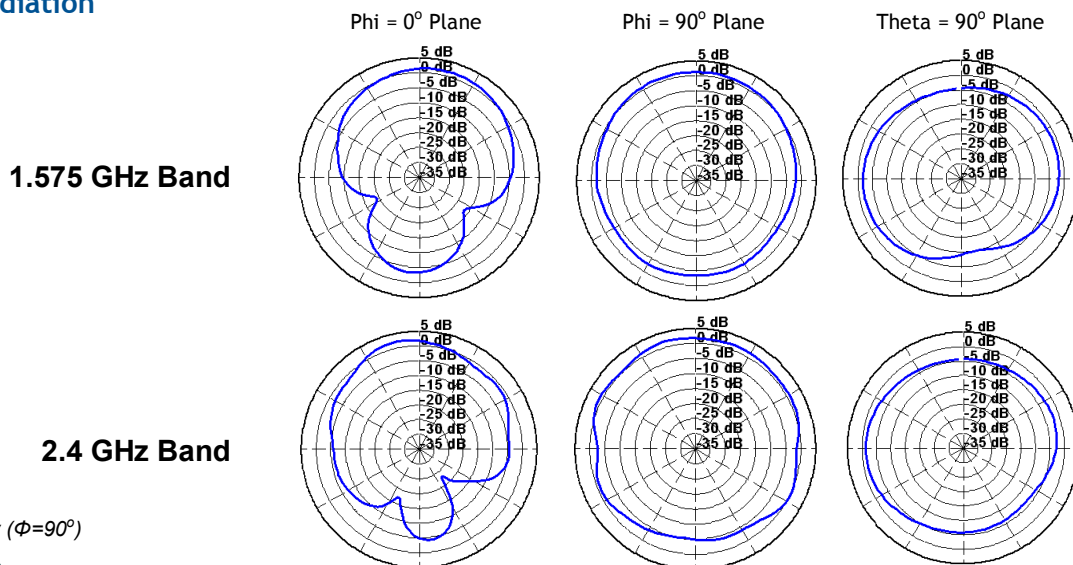

Typical Performance  
Ethertronics' Test Board  
PCB: 40x80mm

## Antenna Application Note

To optimize product designs using Ethertronics Savvi™ Bluetooth®/GPS antennas, the PCB should use the recommended land pattern shown in the Figures below. The land patterns are composed of a 50 ohm line connected to each antenna feed point. Ground clearance around and under the antenna, as shown in the PCB layout below, is recommended in order to maximize the antenna's performance. The antenna should be located along an edge of the PCB.

### Antenna Pad Layout

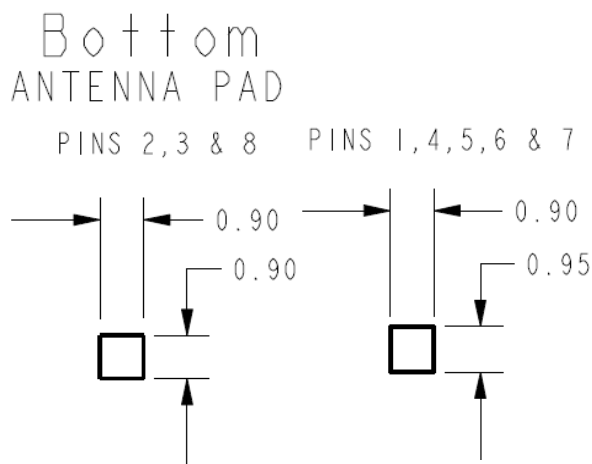

Pin	Description
1	Ground
2	Dummy Pad
3	Dummy Pad
4	Ground
5	BT Feed
6	Ground
7	Ground/ GPS Feed*
8	Dummy Pad

\*See page 20 for information on why the ground and feed line appear to be tied together.

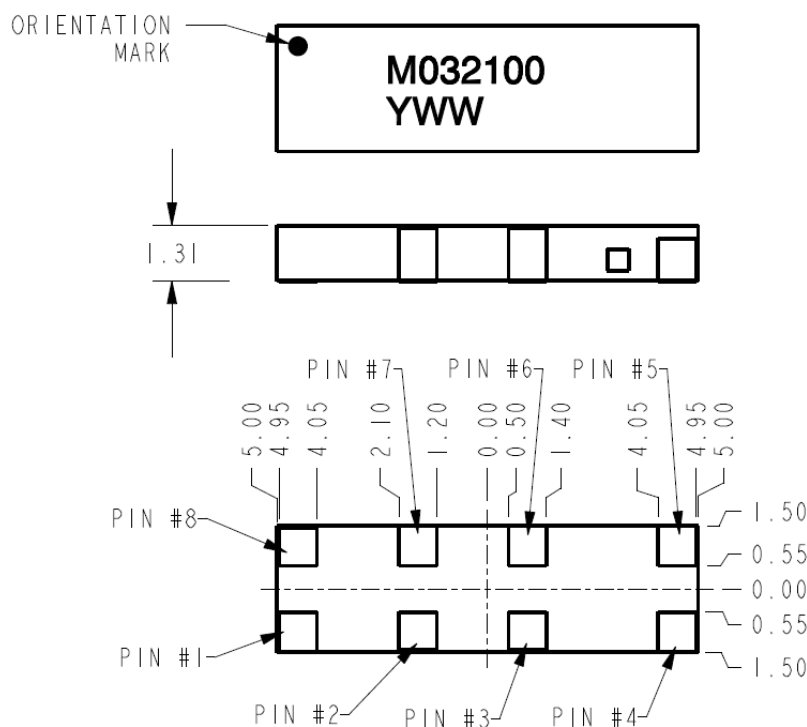

Ethertronics provides antenna layout files in .DXF format. This is a universal file format and should be converted into your specific file format

## Antenna Application Note

To optimize product designs using Ethertronics Savvi™ Bluetooth®/GPS antennas, the PCB should use the recommended land pattern shown in the Figures below. The land patterns are composed of a 50 ohm line connected to each antenna feed point. Ground clearance around and under the antenna, as shown in the PCB layout below, is recommended in order to maximize the antenna's performance. The antenna should be located along an edge of the PCB.

### Antenna Pad Layout

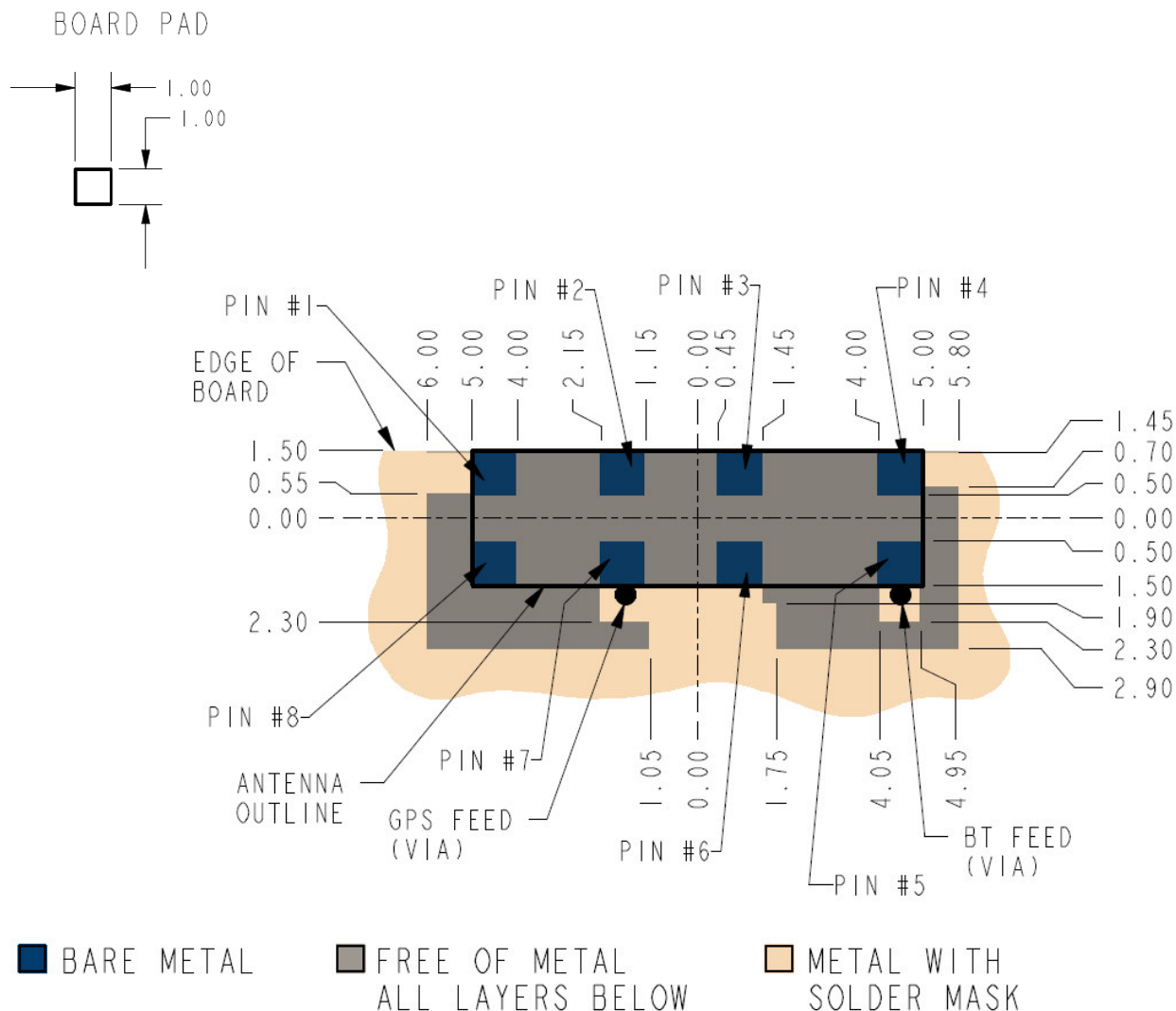

Ethertronics provides antenna layout files in .DXF format. This is a universal file format and should be converted into your specific file format