

## Contents

1	Description.....	2
1.1.	General.....	2
1.2.	ZSSC3131 and ZSSC3136 Sensor Conditioners.....	2
1.3.	Benefits for Automotive Switch Applications .....	2
2	Setting up the ZSSC3131/36 for Switching Applications .....	3
2.1.	Threshold with Offset and Hysteresis.....	3
2.2.	Alarm Window.....	6
2.3.	Digital Filter.....	7
2.4.	Fast or Slow Switches .....	8
3	Application Circuits.....	9
4	Related Documents.....	11
5	Glossary .....	11
6	Document Revision History.....	12

## List of Figures

Figure 2.1	Calibration Window.....	3
Figure 2.2	Switch Implementation.....	4
Figure 2.3	Switch with Hysteresis .....	5
Figure 2.4	Switch Setting Example .....	5
Figure 2.5	Sensor Range Correction .....	6
Figure 3.1	Sensor Switch Application Driving a Relay.....	9
Figure 3.2	Sensor Switch Application Connected to a Microcontroller.....	9
Figure 3.3	Alarm Window.....	10
Figure 3.4	Adding Hysteresis to the Output .....	10

## List of Tables

Table 2.1	Alarm Window Operation using Two Comparators .....	6
Table 2.2	Fast vs. Slow Switch Setup .....	8

# 1 Description

## 1.1. General

This document describes how to setup switch applications based on the ZSSC3131 and ZSSC3136 sensor conditioners, using the ZSSC313x Graphic User Interface (GUI). ZSSC313x family ICs are designed for automotive and industrial sensor signal conditioning (SSC) applications requiring a high degree of accuracy, strong ESD protection, and EMC immunity.

Limit control is a common application for sensor switches, and it is an integral part of many sensing systems. Sensor switches have found many applications in automotive, industrial and consumer electronics.

Sensing parameters for the ZSSC3131/36 can be

- **Pressure**
- **Flow**
- **Force, torque, and acceleration**
- **Proximity and similar measurements**

Typical applications, especially automotive uses, include engine oil pressure measurement, hydraulic brake systems, brake lights, dust control applications, fuel level gauges, filter systems, feedback for gear selection, clutch controls, and many others. ZSSC313x ICs are also applicable in HVAC and cooling systems.

## 1.2. ZSSC3131 and ZSSC3136 Sensor Conditioners

The ZSSC3131 and the ZSSC3136 are part of the ZSSC313x product family for automotive applications featuring the following functionality:

- **Protection:** excellent electromagnetic behavior as well as **AEC-Q100** qualification.
- **Flexibility:** analog front-end (AFE) fits a wide range of sensors.
- **Output:** ratiometric analog voltage output between 5% and 95% of maximum 5.5V supply voltage.
- **Threshold and slew rate:** adjustable via EEPROM settings.
- **Safety:** features for meeting **SIL2** requirements (for ZSSC3136 only).

## 1.3. Benefits for Automotive Switch Applications

Many of the advantages of the ZSSC3131/36 are specifically designed for automotive sensor switch applications:

- All settings are stored in an internal EEPROM.
- High accuracy can be achieved because the sensor signal used to trigger the switch has been conditioned.
- Flexible analog front-end allows configuration for nearly all resistive bridge sensor elements.
- Both ZSSC3131 and ZSSC3136 have automotive qualification and integrated automotive protection circuits.
- Integrated safety functions allow setting up **SIL2**-rated switch applications using the ZSSC3136.

## 2 Setting up the ZSSC3131/36 for Switching Applications

The ZSSC3131/36 output pin 9 (AOUT) is an analog voltage output within the range of 5% to 95% of the supply voltage VDDE. Depending on the calibration setup used, this output can have the functionality of either a ratio-metric output voltage or of a switch (Alarm).

For using the ZSSC3131/36 with ratio-metric voltage output, the normal calibration procedure is used (see the *ZSSC313x Evaluation Kit Description* for details).

For switch configuration, refer to the following sections for setting the critical switch parameters. These settings refer to a linear calibration procedure (two-point calibration).

**Figure 2.1 Calibration Window**

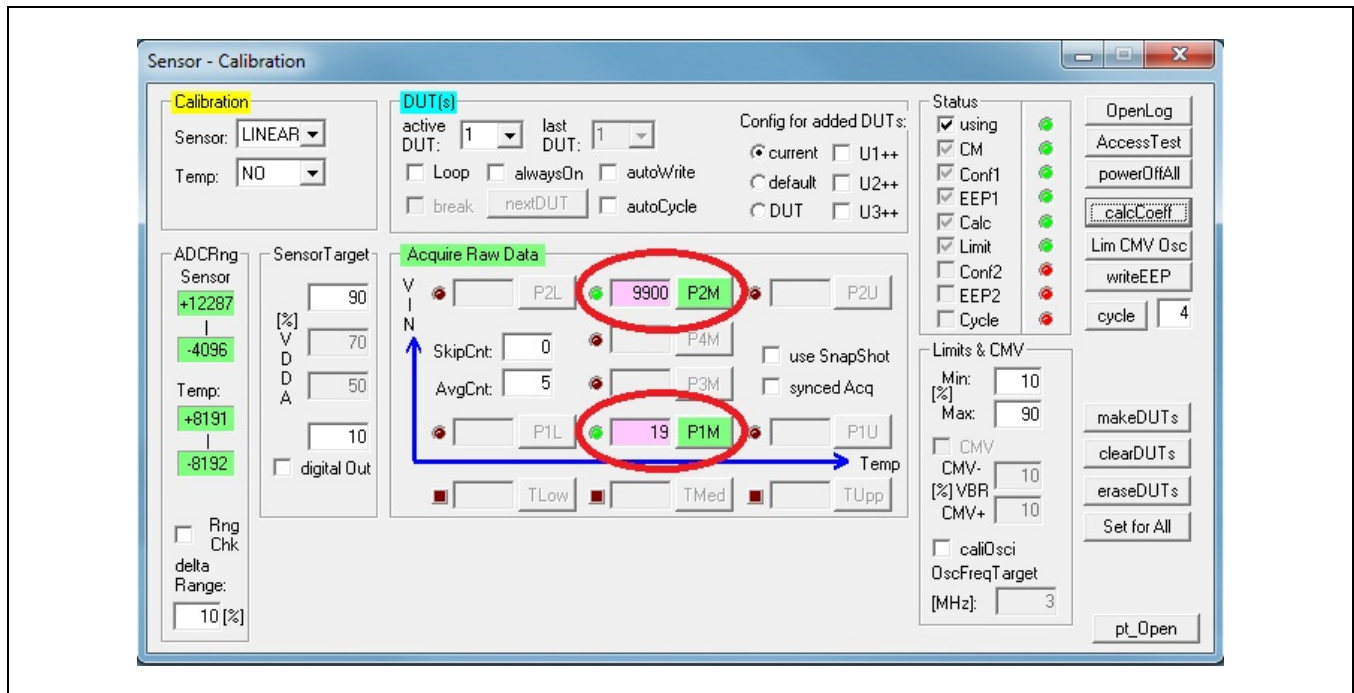

### 2.1. Threshold with Offset and Hysteresis

The threshold or the switching point is where the output voltage changes between the set maximum and minimum level ( $V_{MIN}$  and  $V_{MAX}$ ); i.e., the switch is triggered.

To design a switch with the ZSSC3131 or ZSSC3136, first a normal calibration procedure should be performed. This will determine the raw data values (P1M and P2M as shown in Figure 2.1) corresponding to the minimum and maximum ( $V_{MIN}$  and  $V_{MAX}$ ) output levels (see Figure 2.2).

Next the thresholds, including offset, can be calculated using the equations below:

Equations	Symbol Definitions
$p_2 = \frac{P2M - P1M}{100} * p_{Th}[\%] + P1M$	$p_1, p_2$ : Threshold levels. If $p_2$ is greater than $p_1$ (positive offset), then the output signal is active-HIGH and vice versa.
$p_1 = p_2 + /- \text{Offset}$	$P1M, P2M$ : Acquired raw data from initial calibration.
$P1M < p_1 < p_2 \text{ or } P1M < p_2 < p_1$ (active-HIGH or active-LOW signal)	Offset: Number of steps between $V_{MIN}$ and $V_{MAX}$ corresponding to the raw data values.
$p_1 < p_2 < P2M \text{ or } p_2 < p_1 < P2M$ (active-HIGH or active-LOW signal)	$p_{Th} [\%]$ : Desired switching level in percentage of the sensor signal range (0% - 100%).
$1 \leq \text{Offset} \leq (P2M - P1M)$	$V_{MIN}, V_{MAX}$ : Minimum and maximum of analog output AOUT.  $V_{DD}$ : Supply voltage (Max. 5.5V).  Active-HIGH/LOW: Depending on the sign used for the offset active-HIGH (-) or active LOW (+) output is defined.

**Figure 2.2 Switch Implementation**

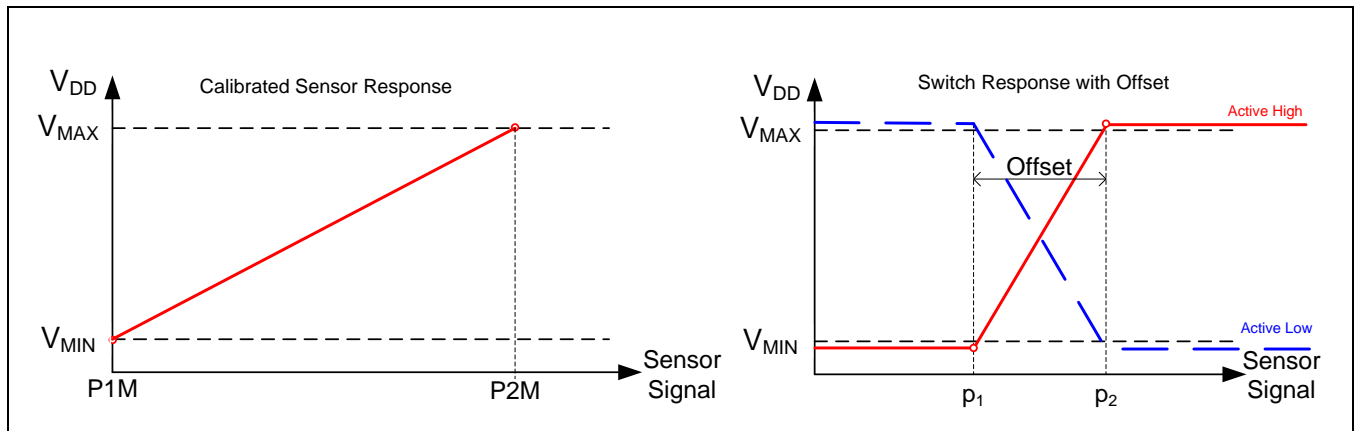

An actual hysteresis can be achieved using external components (for example a Schmitt trigger as shown in Figure 3.4). Trigger levels can be any levels within the  $V_{MIN}$  and  $V_{MAX}$  window (maximum is 5% to 95% of  $V_{DD}$ ). In normal cases, these differ from  $V_{MIN}$  and  $V_{MAX}$  and  $p_1$  and  $p_2$  must be adjusted as described in section 2.2.

**Figure 2.3 Switch with Hysteresis**

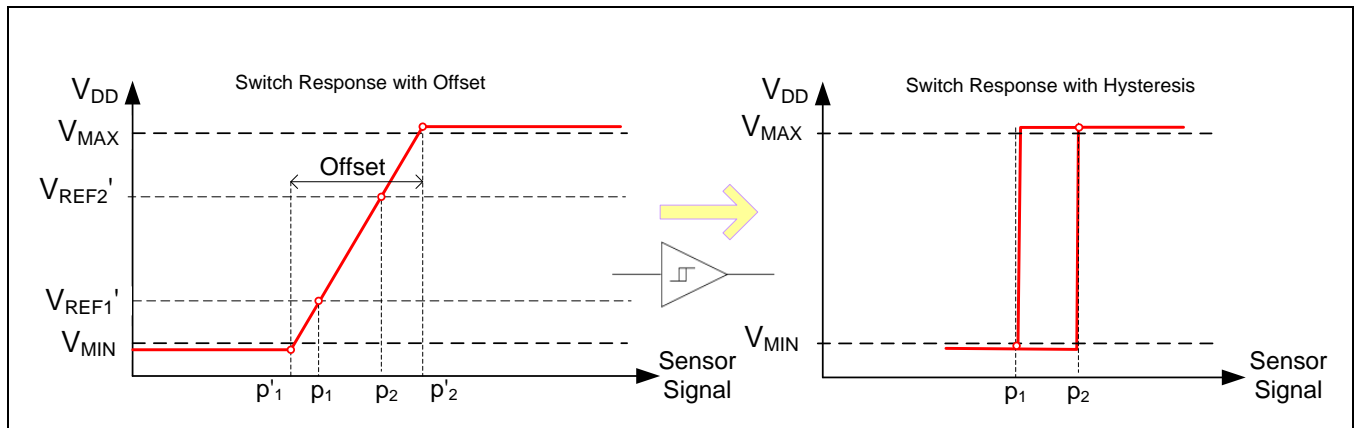

Note that the  $p_1$  and  $p_2$  parameters should not exceed the P1M and P2M values.

To complete the procedure for setting the switch threshold and offset, the P1M and P2M values must be replaced with the calculated  $p_1$  and  $p_2$  and **the coefficients must be calculated and stored again by clicking `calcCoef`**.

**Example:** Calibrating a pressure sensor using the ZSSC3131. Measured P1M = 100 (at 0 psi for 0%) and P2M = 8000 (at 10psi for 100%). The trigger level is chosen as 50% and hysteresis at 100, active-HIGH (-):

$$\text{Result} \rightarrow P2M = p_2 = \frac{8000 - 100}{100} * 50 + 100 = 4050 \quad P1M = p_1 = 4050 - 100 = 3950$$

**Figure 2.4 Switch Setting Example**

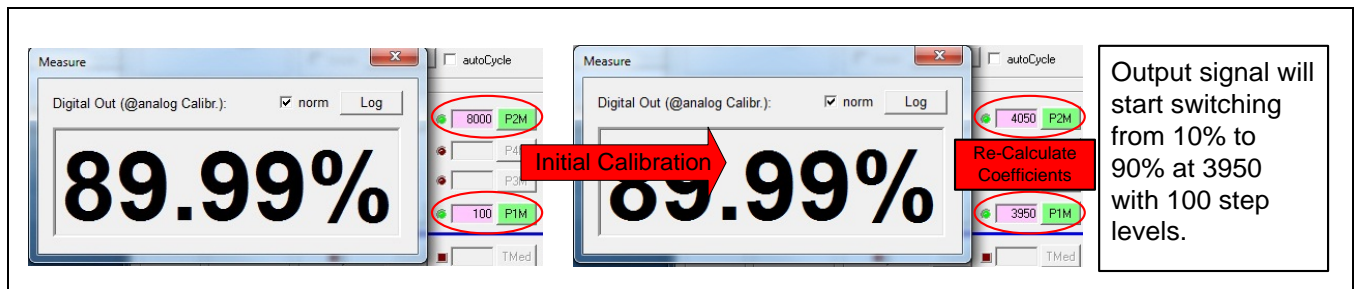

## 2.2. Alarm Window

In order to achieve an alarm window with a single analog voltage output, external components must be added as shown in the application circuits in section 3.

There are two external reference voltages ( $V_{REF1}$  and  $V_{REF2}$  corresponding to sensor outputs  $p_1$  and  $p_2$ ) setting the trigger points and shaping the alarm window. When the output voltage is within the desired limits, both comparator outputs are HIGH, so no current is running through the load  $R_L$  (see Figure 3.3).

**Table 2.1 Alarm Window Operation using Two Comparators**

Input	Inverting	Non-Inverting	Load
$V < V_{REF1}$	HIGH	LOW	On
$V_{REF1} < V < V_{REF2}$	HIGH	HIGH	Off
$V > V_{REF2}$	LOW	HIGH	On

If the alarm window is relatively narrow, it makes sense to adjust the calibration of the sensor so that the output response is within user-selected margins, for example  $\pm\Delta p$ , of the alarm window (see Figure 2.5). This will increase the voltage difference ( $\Delta V$ ) of the trigger points and will make the actual schematic implementation easier. However, the change in the trigger levels should be taken into account for the given switching points using the subsequent equations. Formulas for calibration values based on actual measured trigger levels are also given.

**Figure 2.5 Sensor Range Correction**

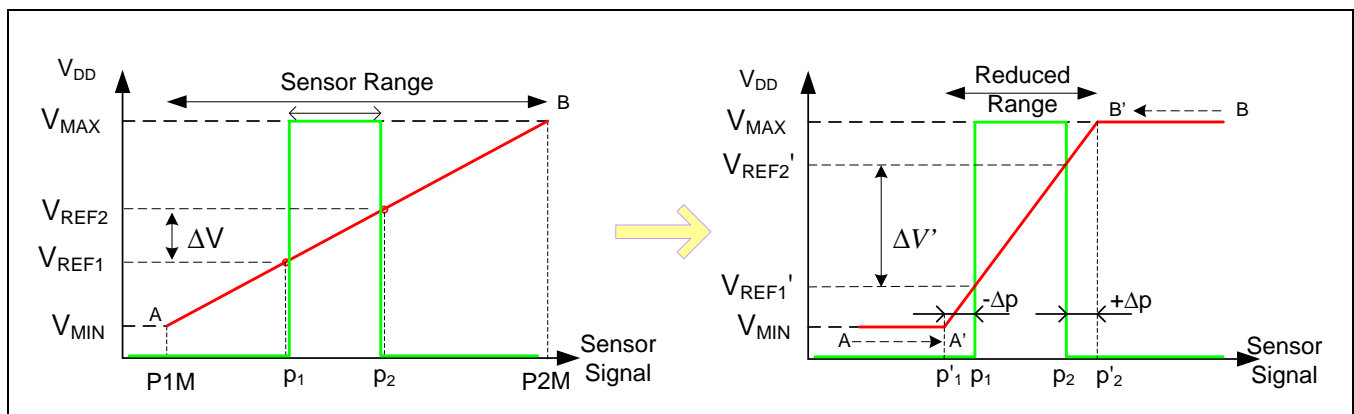

Subsequent calculations:	With given trigger levels $V'_{REF1}$ and $V'_{REF2}$ and defined window points $p_{1/2}$ [%] (reverse task):
$p_{1/2} = \frac{P2M - P1M}{100} p_{1/2}[\%] + P1M$ $V_{REFn} = (V_{MIN} + \frac{V_{MAX} - V_{MIN}}{100} p_n[\%]) \frac{V_{DD}}{100}$ $p'_1 = p_1 - \Delta p \quad p'_2 = p_2 + \Delta p$ $V'_{REF1} = \frac{\Delta p}{p'_2 - p'_1} (V_{MAX} - V_{MIN}) + V_{MIN}$ $V'_{REF2} = \frac{p_2 - p'_1}{p'_2 - p'_1} (V_{MAX} - V_{MIN}) + V_{MIN}$	$p_{1/2} = \frac{P2M - P1M}{100} p_{1/2}[\%] + P1M$ $p'_1 = \frac{p_1 k_2 - p_2 k_1}{k_2 - k_1}$ $p'_2 = p'_1 + \frac{p_2 - p'_1}{k_2} (V_{MAX} - V_{MIN})$ <p>Where</p> $k_1 = V'_{REF1} - V_{MIN} \quad k_2 = V'_{REF2} - V_{MIN}$

### 2.3. Digital Filter

The ZSSC3131 and ZSSC3136 offer a digital (averaging) filter function for calculating the output result. In practice, the digital filter adds the limitation of the analog output signal change (raise or fall).

Mathematically the function can be described with the following equations:

Equations	Symbol Definitions
$S_{OUTi} = S_{OUTi-1} + (S_i - S_{OUTi-1}) * \frac{LPF_{DIFF} + 1}{2^{LPF_{AVRG}}}; \quad i > 0;$ $S_{AVRG}, S_{DIFF} \in [0;7]$ $\frac{LPF_{DIF} + 1}{2^{LPF_{AVGR}}} \leq 1$	<p><math>S_i</math> : Conditional equation result</p> <p><math>S_{OUTi}</math> : Output result to be calculated</p> <p><math>LPF_{DIFF}</math> : Low pass filter differential coefficient (differential)</p> <p><math>LPF_{AVG}</math> : Averaging low pass filter coefficient (integrating)</p>

Note that the  $\frac{LPF_{DIFF} + 1}{2^{LPF_{AVRG}}}$  coefficient must never become larger than 2! Otherwise, the filter function will oscillate and the system would have a flywheel effect.

The output  $S_{OUTi}$  is set to  $S_i$  for the first calculation of an output result.

The difference between this filter function and the function described in section 2.1 is that the output result is changing per measuring cycle (at specific time intervals). It is a purely software solution for noise immunity that adds a delay to the response even if the trigger point is reached.

Note that setting the coefficients  $LPF_{AVRG}$  and  $LPF_{DIFF}$  to 0 disables the filter function.

## 2.4. Fast or Slow Switches

Depending on the target applications, both fast and slow switches can be achieved using ZSSC3131/36 signal conditioners. An ON/OFF delay can be implemented externally by adding a delay section in the drive circuit based on passive components. Table 2.2 outlines the applicable configuration:

**Table 2.2 Fast vs. Slow Switch Setup**

Switch	Offset	Hysteresis	Digital Filter	Delay	Comments
<b>Fast Switch</b>	Yes/No	Yes	No	No	The switch will trigger once the threshold level is reached. External hysteresis can be used for noise immunity.
<b>Slow Switch</b>	Yes/No	Yes	Yes	Yes	All configuration parameters are applicable for shaping the output response.

### 3 Application Circuits

Figure 3.1 Sensor Switch Application Driving a Relay

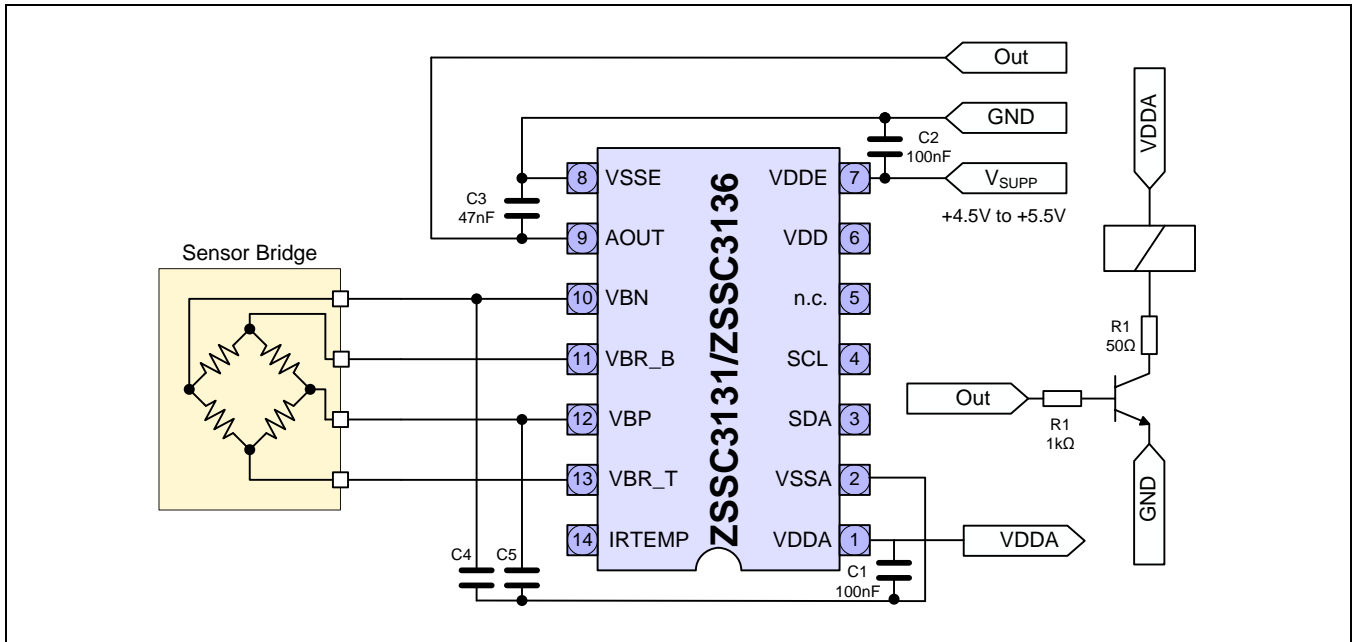
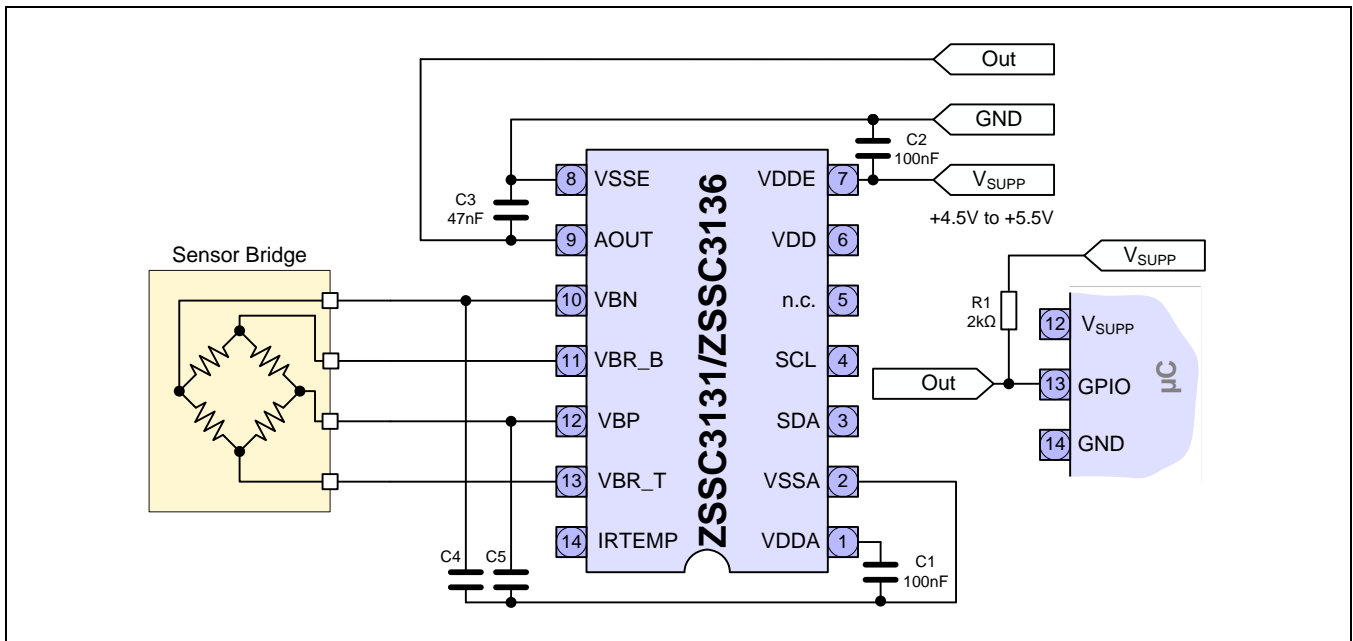

Figure 3.2 Sensor Switch Application Connected to a Microcontroller





## 4 Related Documents

Document
ZSSC313x Functional Description
ZSSC313x Evaluation Kit Description
ZSSC313x High Voltage Protection Description
<b>ZSSC3131 Documents</b>
ZSSC3131 Feature Sheet
ZSSC3131 Data Sheet
<b>ZSSC 3136 Documents</b>
ZSSC3136 Feature Sheet
ZSSC3136 Data Sheet

Visit IDT's website [www.IDT.com](http://www.IDT.com) or contact your nearest sales office for the latest version of these documents.

## 5 Glossary

Term	Description
AEC	Automotive Electronics Council
EEPROM	Electrically Erasable Programmable Read Only Memory
ESD	Electrostatic Device
SIL	Safety Integrity Level

## 6 Document Revision History

Revision	Date	Description
1.00	May 30, 2012	First release.
	March 30, 2016	Changed to IDT branding.



Corporate Headquarters  
6024 Silver Creek Valley Road  
San Jose, CA 95138  
[www.IDT.com](http://www.IDT.com)

Sales  
1-800-345-7015 or 408-284-8200  
Fax: 408-284-2775  
[www.IDT.com/go/sales](http://www.IDT.com/go/sales)

Tech Support  
[www.IDT.com/go/support](http://www.IDT.com/go/support)

DISCLAIMER Integrated Device Technology, Inc. (IDT) reserves the right to modify the products and/or specifications described herein at any time, without notice, at IDT's sole discretion. Performance specifications and operating parameters of the described products are determined in an independent state and are not guaranteed to perform the same way when installed in customer products. The information contained herein is provided without representation or warranty of any kind, whether express or implied, including, but not limited to, the suitability of IDT's products for any particular purpose, an implied warranty of merchantability, or non-infringement of the intellectual property rights of others. This document is presented only as a guide and does not convey any license under intellectual property rights of IDT or any third parties.

IDT's products are not intended for use in applications involving extreme environmental conditions or in life support systems or similar devices where the failure or malfunction of an IDT product can be reasonably expected to significantly affect the health or safety of users. Anyone using an IDT product in such a manner does so at their own risk, absent an express, written agreement by IDT.

Integrated Device Technology, IDT and the IDT logo are trademarks or registered trademarks of IDT and its subsidiaries in the United States and other countries. Other trademarks used herein are the property of IDT or their respective third party owners. For datasheet type definitions and a glossary of common terms, visit [www.idt.com/go/glossary](http://www.idt.com/go/glossary). All contents of this document are copyright of Integrated Device Technology, Inc. All rights reserved.